

site plan

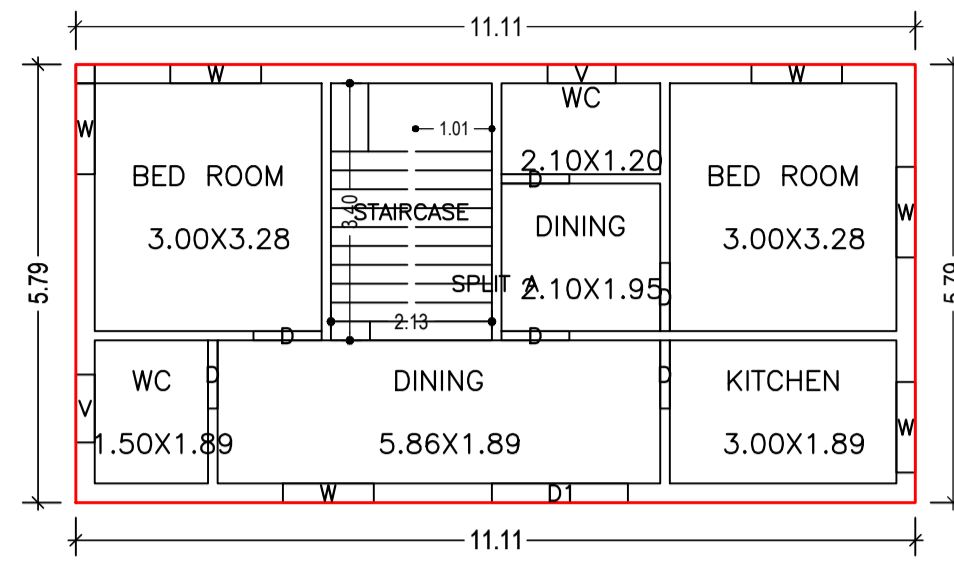

GROUND FLOOR PLAN (Proposed) (SCALE 1:100)

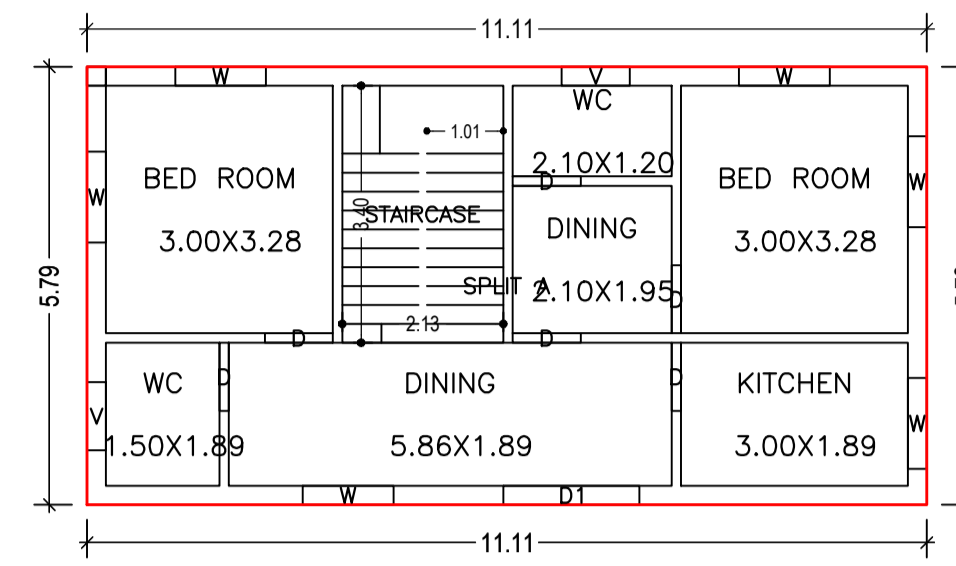

FIRST FLOOR PLAN (Proposed) (SCALE 1:100)

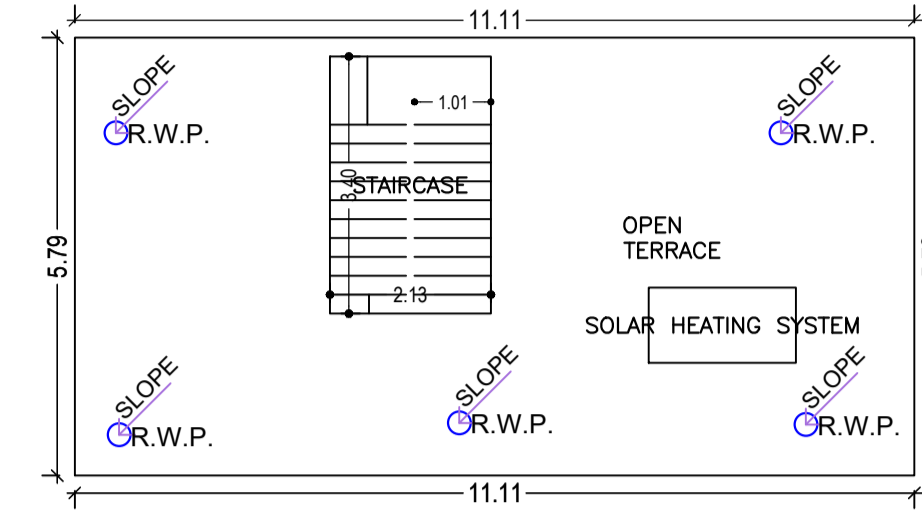

TERRACE FLOOR PLAN (SCALE 1:100)

Proposal Basic Information	
Proposal File No.	MNNP/BI/0338/W03/2022
Owner Name	PUJA KUMARI
Khata No	25
Plot No	239/406
Village Name	Sudna
Use	Residential
SubUse	Bungalow/ Dwelling / Non Apartment

AREA STATEMENT		VERSION NO. : 1.0.65
MEDININAGAR MUNICIPAL CORPORATION		VERSION DATE: 16/10/2020
PROJECT DETAIL:		
Region: JHARKHAND URBAN LOCAL BODIES	Plot Use: Residential	
District: PALAMU	Plot SubUse: Bungalow/ Dwelling / Non Apartment	
Authority: MEDININAGAR MUNICIPAL CORPORATION	Plot/Nearby/Religious Structure: NA	
Inward No: MNNP/BI/0338/W03/2022	Plot/SubPlot No: 239/406	
Application Type: General Proposal	North: -	
Project Type: Building Permission	South: -	
Nature of Development: New	East: -	
Location of Development Area: New Area	West: -	
AREA DETAILS:		
AREA OF PLOT (Minimum)	(A)	150.79
Deduction for NetPlot Area		
Surrender Free of Cost		16.95
Total		16.95
NET AREA OF PLOT (Gross Plot Area - Deduction from Gross Plot Area)	(A-Deductions)	133.84
Deduction for Balance Plot Area (from Gross Plot Area)		
Surrender Free of Cost		16.95
Common Plot		21.55
Total		38.49
BALANCE AREA OF PLOT (Net Plot Area - Recreational/Amenity space)	(A-Deductions)	112.30
PLOT AREA FOR COVERAGE (Net Plot Area)	(A-Deductions)	133.84
Plot Area for FAR (Net Plot Area + Road Widening Area)	(A-Deductions)	150.79
COVERAGE CHECK		
Permissible Coverage area (70.00 %)		93.69
Proposed Coverage Area (48.07 %)		64.34
Total Prop. Coverage Area (48.07 %)		64.34
Balance coverage area (21.93 %)		29.35
FAR CHECK		
Perm. FAR Area (1.500)		226.18
Total Perm. FAR area		226.18
Residential FAR		128.68
Proposed FAR Area		128.68
Total Proposed FAR Area		128.68
Consumed FAR (Factor)		0.85
Balance FAR Area		97.50
BUILT UP AREA CHECK		
Total Proposed BuiltUp Area		128.68
ARCHITECT (Regd)	PANKAJ KUMAR SINGH	
ENGINEER (Regd)		
SUPERVISOR (Regd)		
OWNER (Regd)	PUJA KUMARI	
DEVELOPMENT AUTHORITY		
	LOCAL BODY	

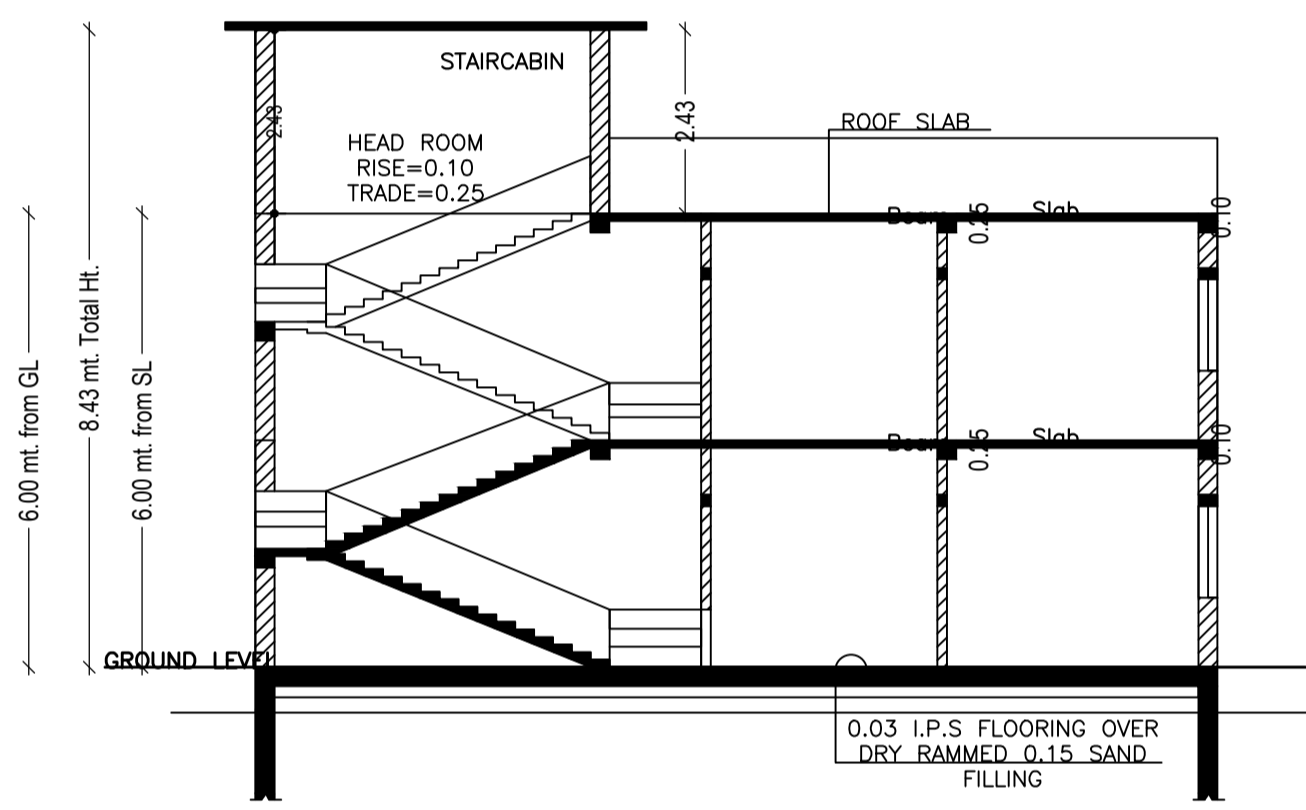

SECTION ON-XX

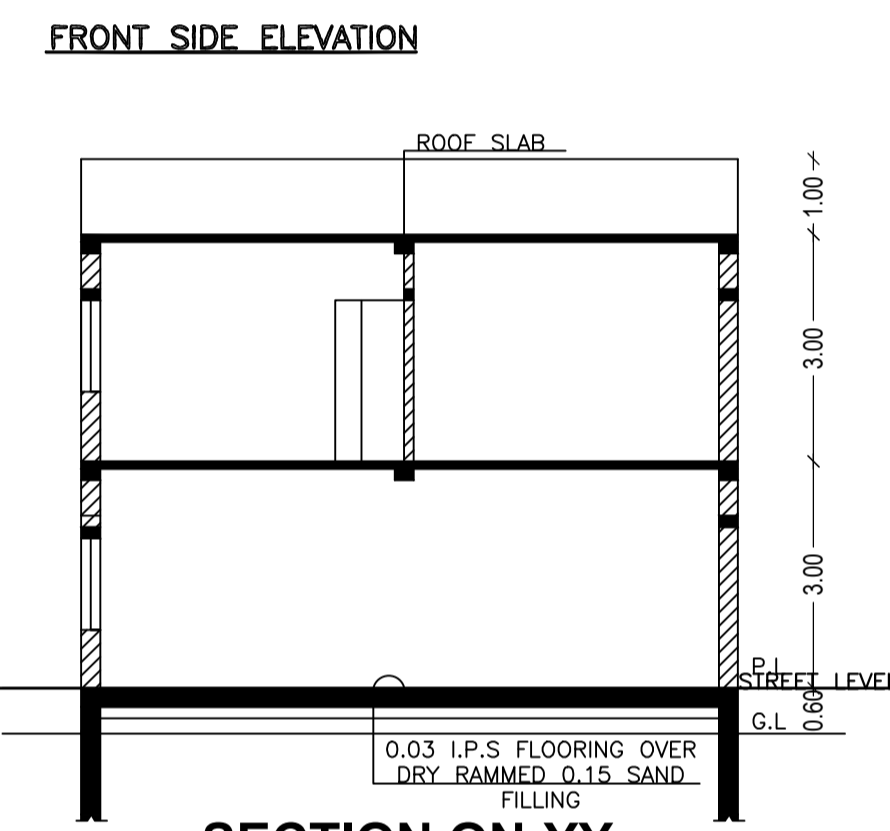

SECTION ON-YY

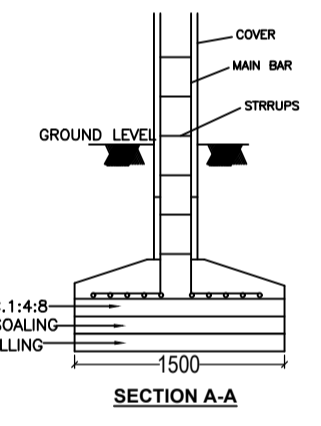
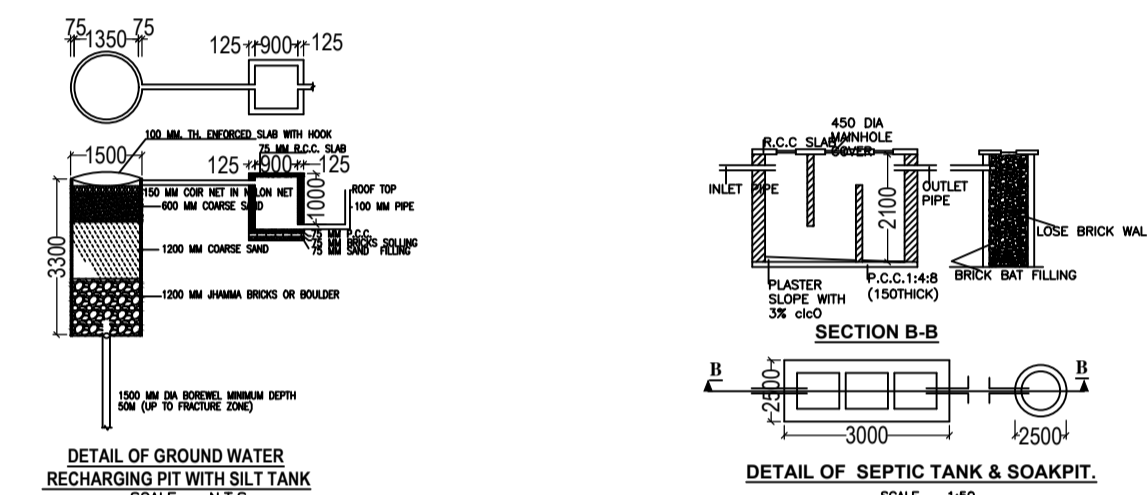

DETAIL OF FOUNDATION SCALE - N.T.S.

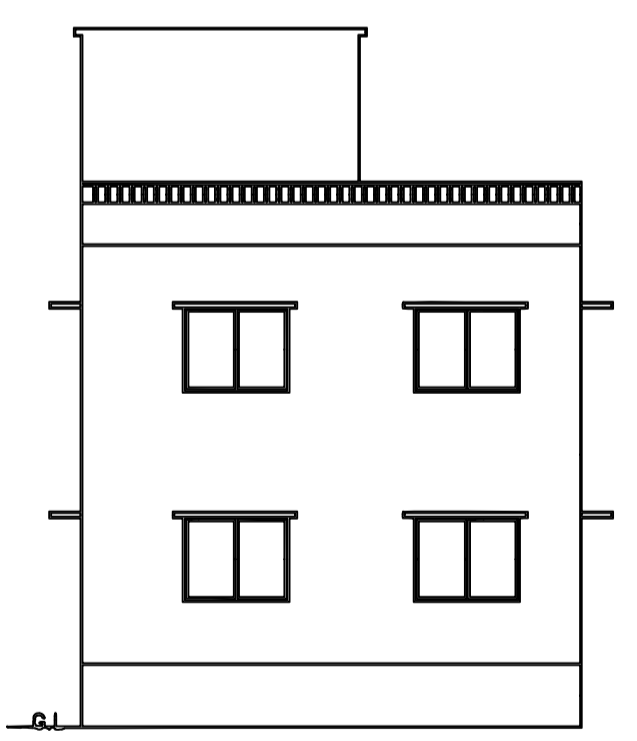
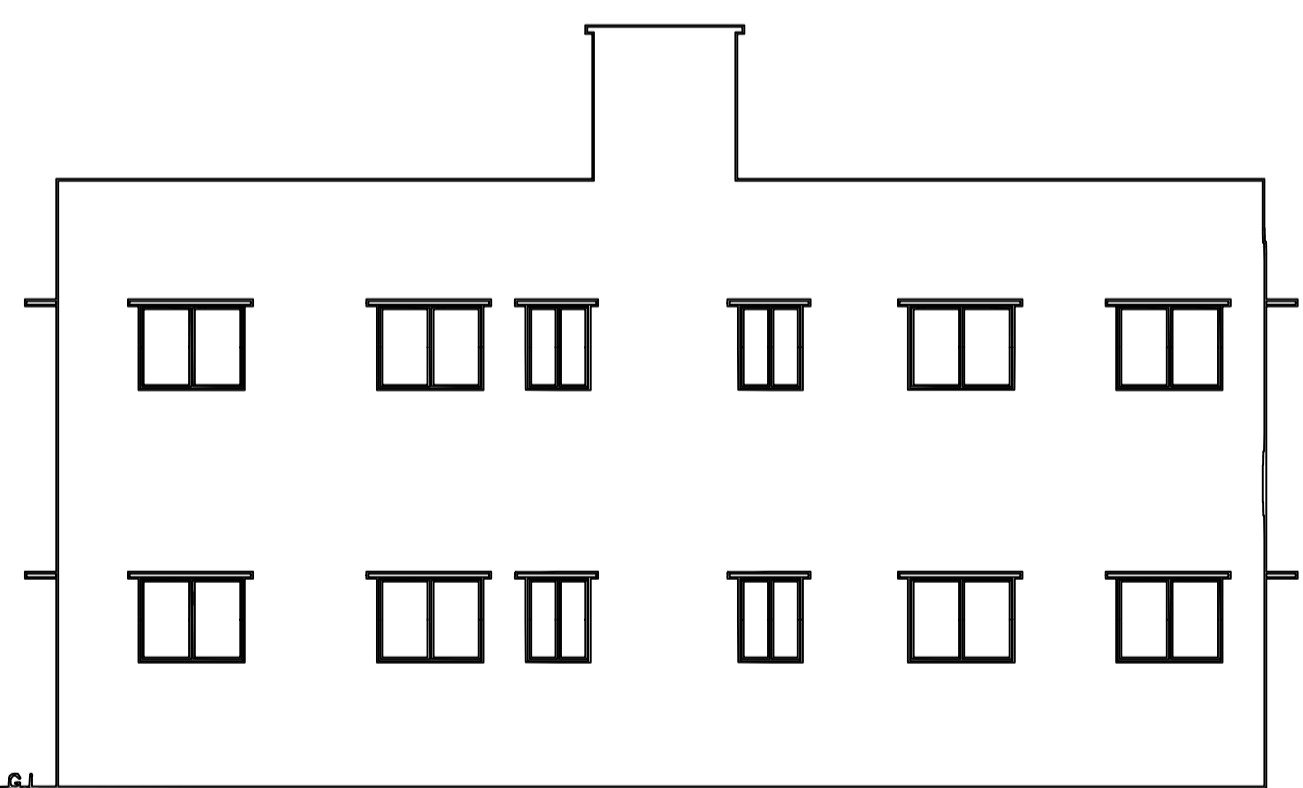

UnitBUA Table for Building :A (BUILDING)

FLOOR	Name	UnitBUA Type	UnitBUA Area	Carpet Area	No. of Rooms	No. of Tenement
GROUND FLOOR PLAN	SPLIT A	FLAT	113.13	113.00	7	1
FIRST FLOOR PLAN	SPLIT A	FLAT	0.00	0.00	7	0
Total:	-	-	113.13	113.00	14	1

Buildingwise Floor FAR Details

Floor Name	Building Name A (BUILDING)		Total	
	Proposed Built Up Area (Sq.mt.)	Proposed FAR Area (Sq.mt.)	Total Proposed Built Up Area (Sq.mt.)	Total FAR Area (Sq.mt.)
Ground Floor	64.34	64.34	64.34	64.34
First Floor	64.34	64.34	64.34	64.34
Terrace Floor	0.00	0.00	0.00	0.00
Total :	128.68	128.68	128.68	128.68

Building :A (BUILDING)

Floor Name	Total Built Up Area (Sq.mt.)	Proposed FAR Area (Sq.mt.) Resi.	Total FAR Area (Sq.mt.)	Total Consumed Additional FAR Area (Sq.mt.)	Tnmt (No.)
Ground Floor	64.34	64.34	64.34	64.34	01
First Floor	64.34	64.34	64.34	64.34	00
Terrace Floor	0.00	0.00	0.00	0.00	00
Total :	128.68	128.68	128.68	128.68	01
Total Number of Same Buildings	1				
Total :	128.68	128.68	128.68	128.68	01

SCHEDULE OF DOOR:

BUILDING NAME	NAME	LENGTH	HEIGHT	NOS
A (BUILDING)	D	0.90	2.10	12
A (BUILDING)	D1	1.80	2.10	02

SCHEDULE OF WINDOW/VENTILATION:

BUILDING NAME	NAME	LENGTH	HEIGHT	NOS
A (BUILDING)	V	0.90	0.60	04
A (BUILDING)	W	1.20	1.20	12

FAR & Tenement Details (Table 4c-1)

Building	No. of Same Bldg	Total Built Up Area (Sq.mt.)	Proposed FAR Area (Sq.mt.) Resi.	Total FAR Area (Sq.mt.)	Total Consumed Additional FAR Area (Sq.mt.)	Tnmt (No.)
A (BUILDING)	1	128.68	128.68	128.68	128.68	01
Grand Total :	1	128.68	128.68	128.68	128.68	01

LTP NAME AND SIGNATURE	STRUCTURAL ENG'S NAME AND SIGNATURE	BUILDER NAME AND SIGNATURE	DIGITAL SIGNATURE
PANKAJ KUMAR SINGH MNNP/ENG/0006/2019			