

SITE PLAN

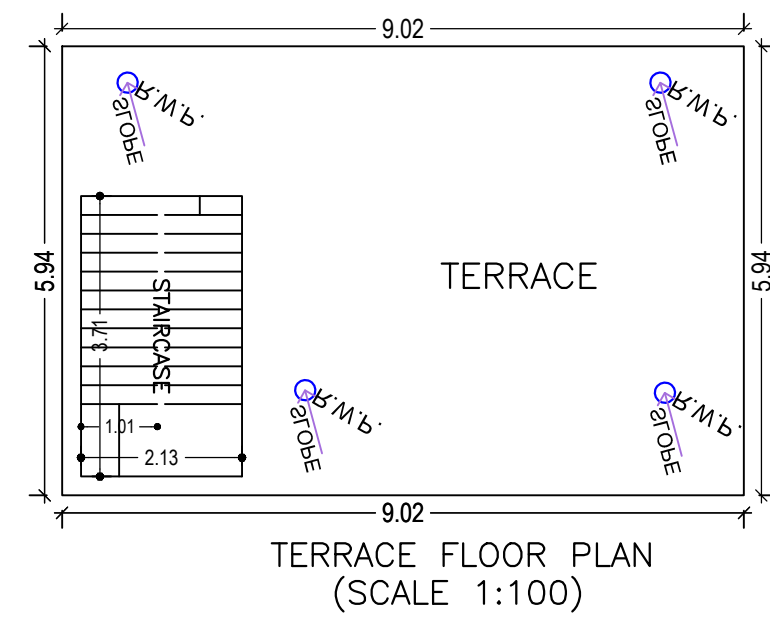

TERRACE FLOOR PLAN (SCALE 1:100)

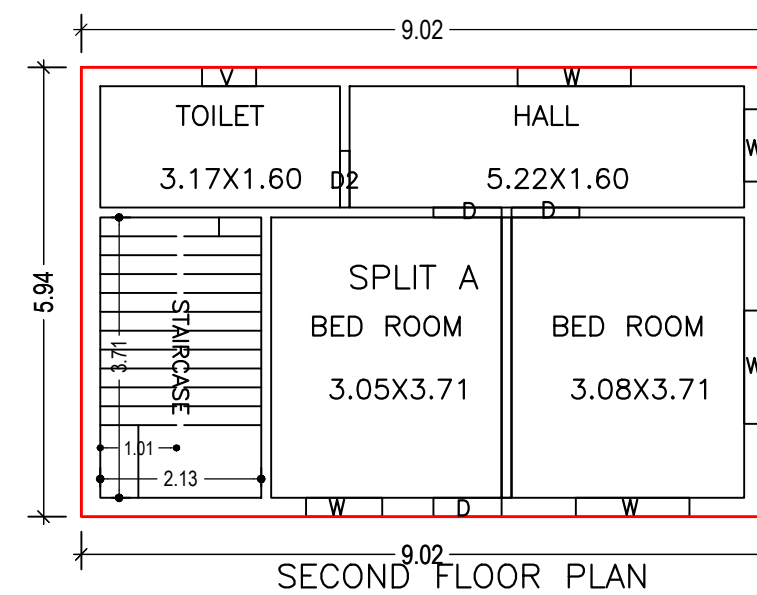

SECOND FLOOR PLAN (Proposed) (SCALE 1:100)

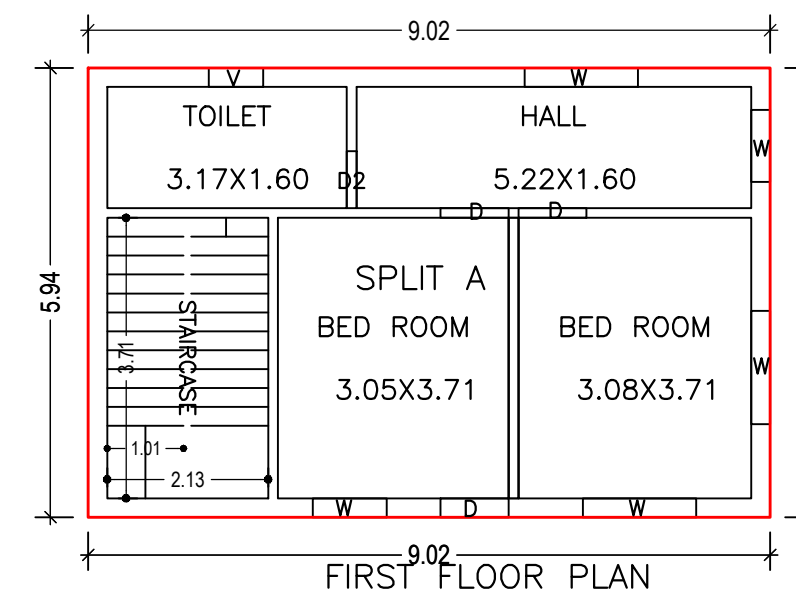

FIRST FLOOR PLAN (Proposed) (SCALE 1:100)

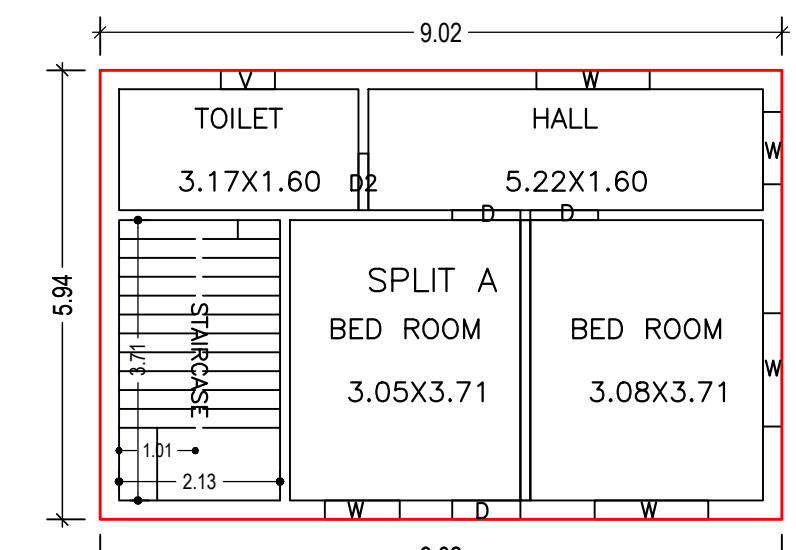

GROUND FLOOR PLAN (Proposed) (SCALE 1:100)

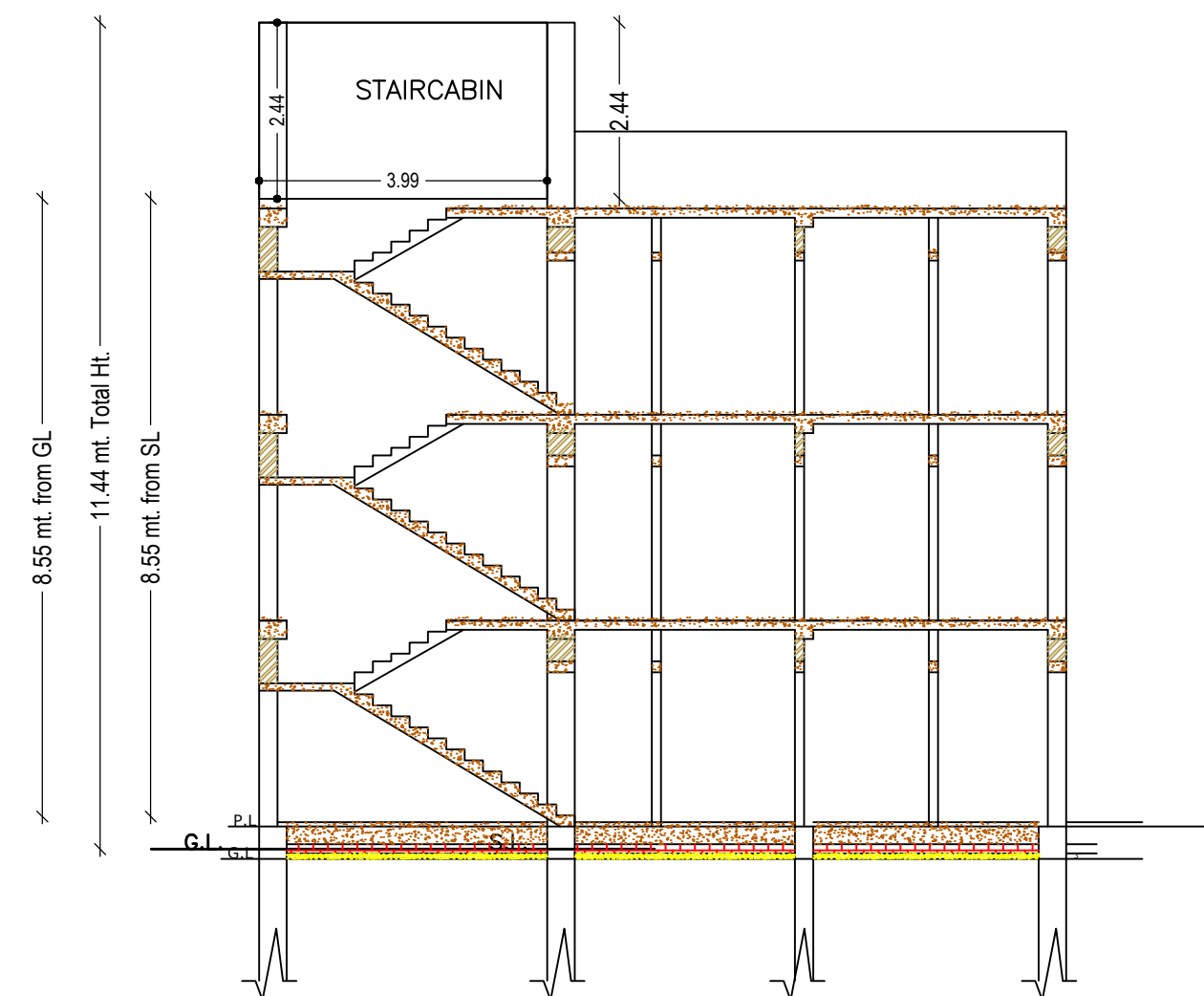

CROSS SECTION (A)

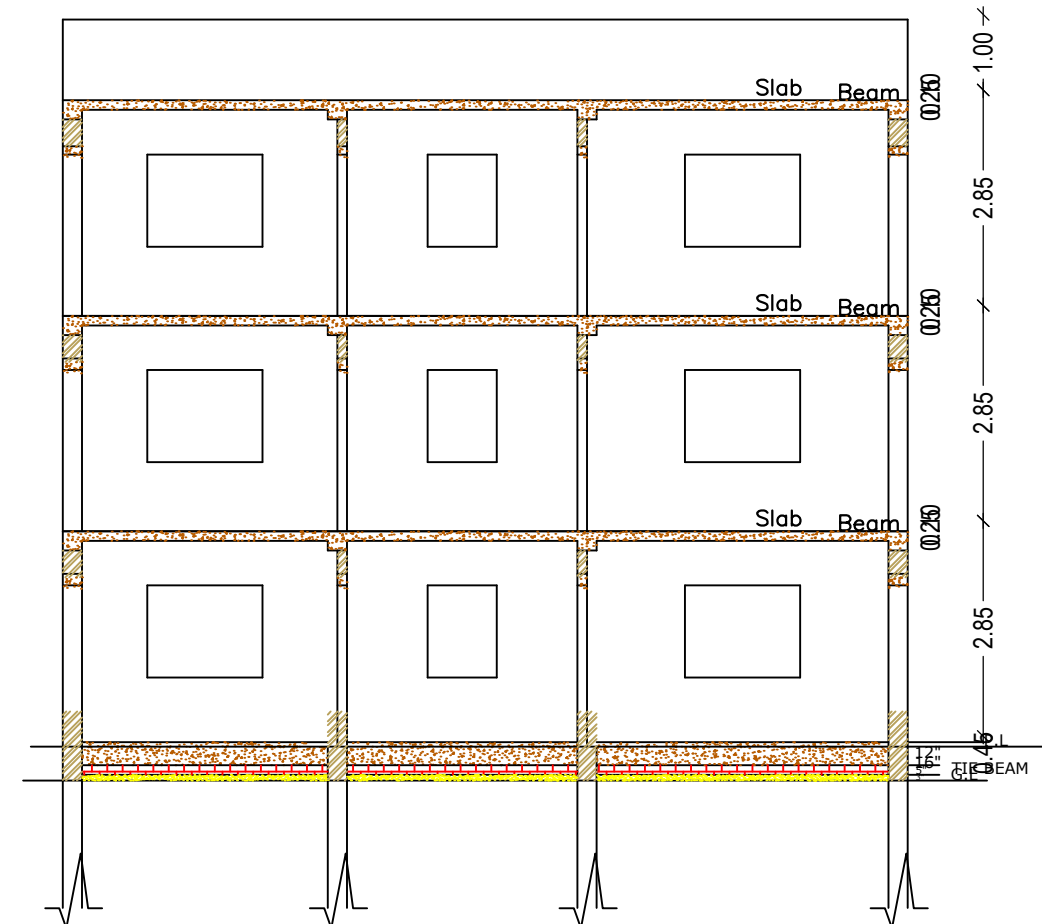

CROSS SECTION (B)

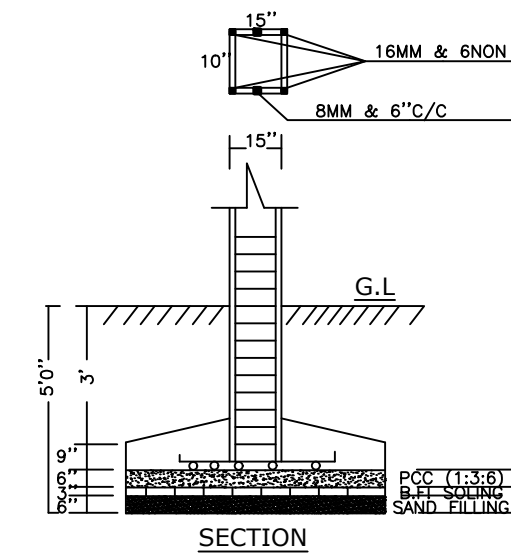

SECTION

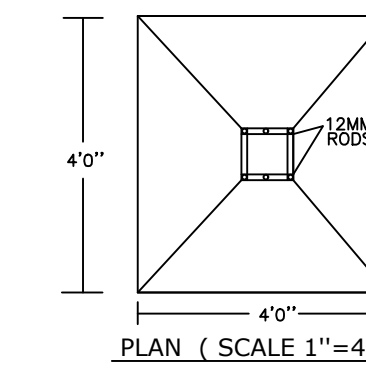

PLAN (SCALE 1"=4')

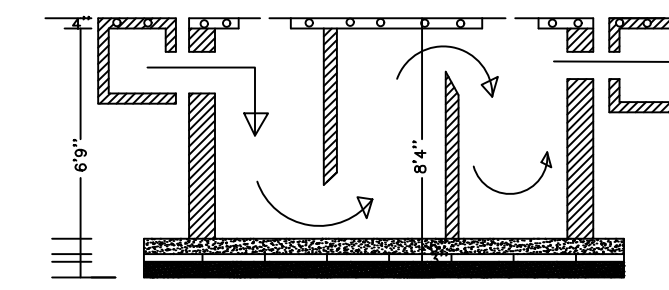

SECTION

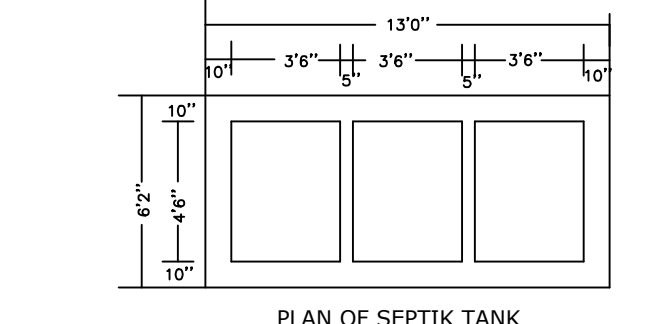

PLAN OF SEPTIK TANK

Proposal Basic Information	
Proposal File No.	MNNP/BI/0343/W06/2022
Owner Name	Mayank Bhardwaj
Khata No	74
Plot No	701
Village Name	Baralota
Use	Residential
SubUse	Bungalow/ Dwelling / Non Apartment

AREA STATEMENT		VERSION NO. : 1.0.65
MEDININAGAR MUNICIPAL CORPORATION		VERSION DATE: 16/10/2020
PROJECT DETAIL:		
Region: JHARKHAND URBAN LOCAL BODIES	Plot Use: Residential	
District: PALAMU	Plot SubUse: Bungalow/ Dwelling / Non Apartment	
Authority: MEDININAGAR MUNICIPAL CORPORATION	PlotNearby/ReligiousStructure: NA	
Inward No: MNNP/BI/0343/W06/2022	Plot/SubPlot No: 701	
Application Type: General Proposal	North: -	
Project Type: Building Permission	South: -	
Nature of Development: New	East: -	
Location of Development Area: Old Area	West: -	
AREA DETAILS:		
AREA OF PLOT (Minimum)	(A)	SQ.MT. 119.18
Deduction for NetPlot Area		
Surrender Free of Cost		20.34
Total		20.34
NET AREA OF PLOT(Gross Plot Area - Deduction from Gross Plot area)	(A-Deductions)	98.84
Deduction for Balance Plot Area(from Gross Plot Area)		
Surrender Free of Cost		20.34
Common Plot		14.84
Total		35.18
BALANCE AREA OF PLOT(Net Plot Area - Recreational/Amenity space)	(A-Deductions)	64.00
PLOT AREA FOR COVERAGE(Net Plot Area + RoadWidening Area)	(A-Deductions)	98.84
Plot Area for FAR (Net Plot Area + RoadWidening Area)	(A-Deductions)	119.18
COVERAGE CHECK		
Permissible Coverage area ( 70.00 % )		69.19
Proposed Coverage Area ( 54.24 % )		53.61
Total Prop. Coverage Area ( 54.24 % )		53.61
Balance coverage area ( 15.76 % )		15.58
FAR CHECK		
Perm. FAR Area ( 1.500 )		178.77
Total Perm. FAR area		178.77
Residential FAR		160.82
Proposed FAR Area		160.82
Total Proposed FAR Area		160.82
Consumed FAR (Factor)		1.35
Balance FAR Area		17.95
BUILT UP AREA CHECK		
Total Proposed BuiltUp Area		160.83
ARCHITECT (Regd)		RANJIT KUMAR
ENGINEER (Regd)		
SUPERVISOR (Regd)		Mayank Bhardwaj
OWNER (Regd)		
DEVELOPMENT AUTHORITY		LOCAL BODY

COLOR INDEX	
PLOT BOUNDARY	Black
ABUTTING ROAD	Green
PROPOSED CONSTRUCTION	Red
COMMON PLOT	Yellow
ROAD WIDENING AREA	Orange
EXISTING (To be retained)	Blue
EXISTING (To be demolished)	Light Blue

Buildingwise Floor FAR Details

Floor Name	Building Name		Total	
	Proposed Built Up Area (Sq.mt.)	Proposed FAR Area (Sq.mt.)	Total Proposed Built Up Area (Sq.mt.)	Total FAR Area (Sq.mt.)
Ground Floor	53.61	53.61	53.61	53.61
First Floor	53.61	53.61	53.61	53.61
Second Floor	53.61	53.61	53.61	53.61
Terrace Floor	0.00	0.00	0.00	0.00
Total :	160.83	160.83	160.83	160.83

Building USE/SUBUSE Details

Building Name	Building Use	Building SubUse	Building Structure
A (RESIDENTIAL)	Residential	Bungalow/ Dwelling / Non Apartment	Non-Highrise

FAR & Tenement Details (Table 4c-1)

Building	No. of Same Bldg	Total Built Up Area (Sq.mt.)	Proposed FAR Area (Sq.mt.) Resi.	Total FAR Area (Sq.mt.)	Total Consumed Additional FAR Area (Sq.mt.)	Trmt (No.)
A (RESIDENTIAL)	1	160.83	160.83	160.83	160.83	01
Grand Total :	1	160.83	160.83	160.83	160.83	01

SCHEDULE OF DOOR:

BUILDING NAME	NAME	LENGTH	HEIGHT	NOS
A (RESIDENTIAL)	D2	0.75	2.10	03
A (RESIDENTIAL)	D	0.90	2.10	09

SCHEDULE OF WINDOW/VENTILATION:

BUILDING NAME	NAME	LENGTH	HEIGHT	NOS
A (RESIDENTIAL)	V	0.72	1.20	03
A (RESIDENTIAL)	W	0.96	1.20	03
A (RESIDENTIAL)	W	0.98	1.20	01
A (RESIDENTIAL)	W	0.99	1.20	01
A (RESIDENTIAL)	W	1.01	1.20	01
A (RESIDENTIAL)	W	1.50	1.20	09

Building :A (RESIDENTIAL)

Floor Name	Total Built Up Area (Sq.mt.)	Proposed FAR Area (Sq.mt.) Resi.	Total FAR Area (Sq.mt.)	Total Consumed Additional FAR Area (Sq.mt.)	Trmt (No.)
Ground Floor	53.61	53.61	53.61	53.61	01
First Floor	53.61	53.61	53.61	53.61	00
Second Floor	53.61	53.61	53.61	53.61	00
Terrace Floor	0.00	0.00	0.00	0.00	00
Total :	160.83	160.83	160.83	160.83	01
Total Number of Same Buildings	1				
Total :	160.83	160.83	160.83	160.83	01

UnitBUA Table for Building :A (RESIDENTIAL)

FLOOR	Name	UnitBUA Type	UnitBUA Area	Carpet Area	No. of Rooms	No. of Tenement
SECOND FLOOR PLAN	SPLIT A	FLAT	0.00	0.00	4	0
FIRST FLOOR PLAN	SPLIT A	FLAT	0.00	0.00	4	0
GROUND FLOOR PLAN	SPLIT A	FLAT	132.54	131.10	4	1
Total:	-	-	132.54	131.10	12	1

LTP NAME AND SIGNATURE	STRUCTURAL ENG'S NAME AND SIGNATURE	BUILDER NAME AND SIGNATURE	DIGITAL SIGNATURE
RANJIT KUMAR MNNP/ENG/0001/2016			