

Building :A (BUILDING)

Floor Name	Total Built Up Area (Sq.mt.)	Proposed FAR Area (Sq.mt.) Resi.	Total FAR Area (Sq.mt.)	Total Consumed Additional FAR Area (Sq.mt.)	Tnmt (No.)
Ground Floor	32.07	32.07	32.07	32.07	01
First Floor	32.07	32.07	32.07	32.07	00
Terrace Floor	0.00	0.00	0.00	0.00	00
<b>Total :</b>	<b>64.14</b>	<b>64.14</b>	<b>64.14</b>	<b>64.14</b>	<b>01</b>
Total Number of Same Buildings	1				
<b>Total :</b>	<b>64.14</b>	<b>64.14</b>	<b>64.14</b>	<b>64.14</b>	<b>01</b>

SCHEDULE OF DOOR:

BUILDING NAME	NAME	LENGTH	HEIGHT	NOS
A (BUILDING)	D	0.90	2.10	02

SCHEDULE OF WINDOW/VENTILATION:

BUILDING NAME	NAME	LENGTH	HEIGHT	NOS
A (BUILDING)	W	1.80	1.20	04

UnitBUA Table for Building :A (BUILDING)

FLOOR	Name	UnitBUA Type	UnitBUA Area	Carpet Area	No. of Rooms	No. of Tenement
GROUND FLOOR PLAN	SPLIT A	FLAT	46.03	44.45	2	1
FIRST FLOOR PLAN	SPLIT A	FLAT	0.00	0.00	2	0
<b>Total:</b>	-	-	<b>46.03</b>	<b>44.45</b>	<b>4</b>	<b>1</b>

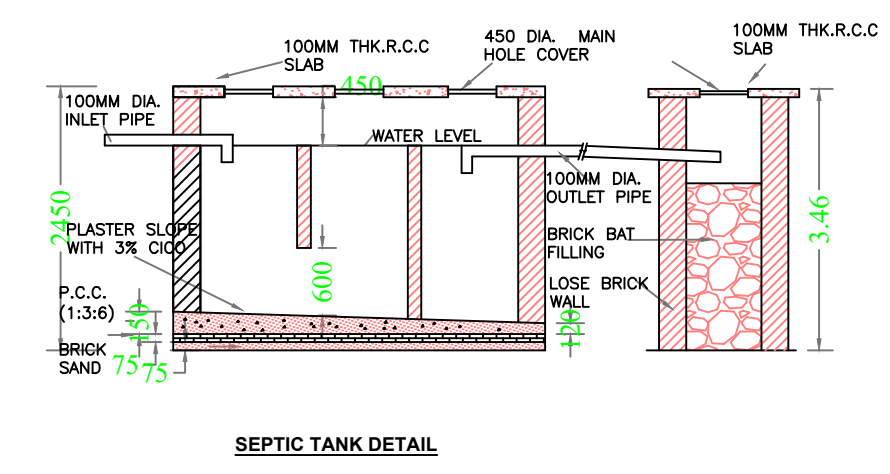
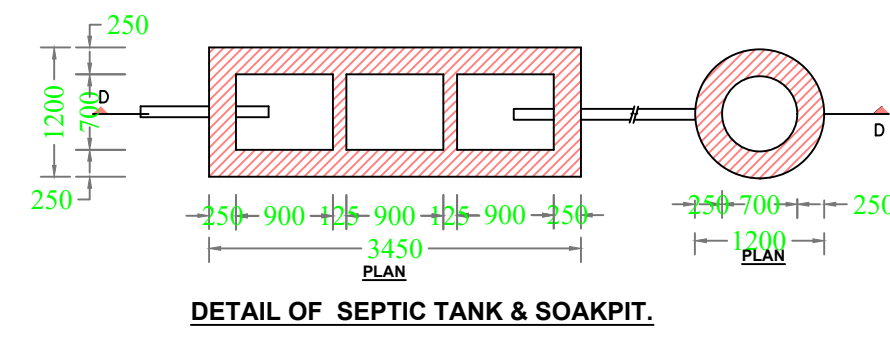

FAR & Tenement Details (Table 4c-1)

Building	No. of Same Bldg	Total Built Up Area (Sq.mt.)	Proposed FAR Area (Sq.mt.) Resi.	Total FAR Area (Sq.mt.)	Total Consumed Additional FAR Area (Sq.mt.)	Tnmt (No.)
A (BUILDING)	1	64.14	64.14	64.14	64.14	01
<b>Grand Total :</b>	<b>1</b>	<b>64.14</b>	<b>64.14</b>	<b>64.14</b>	<b>64.14</b>	<b>01</b>

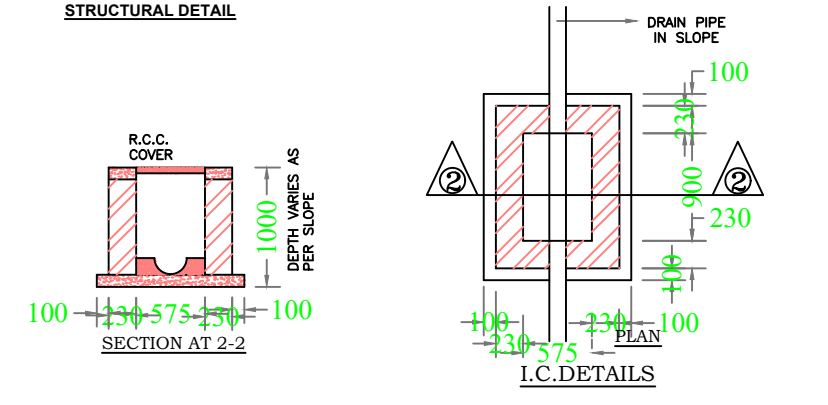
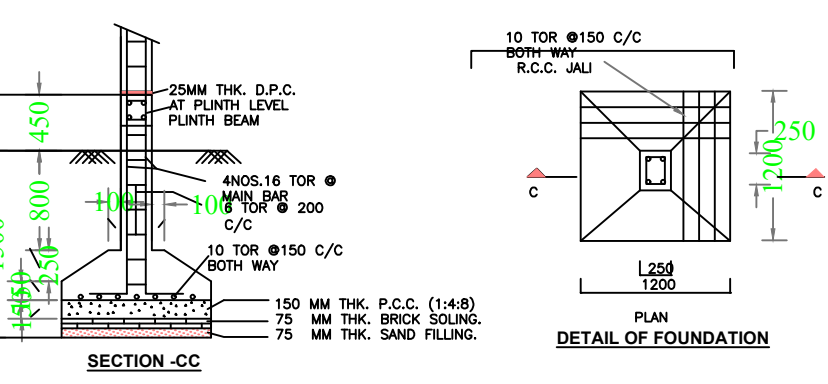
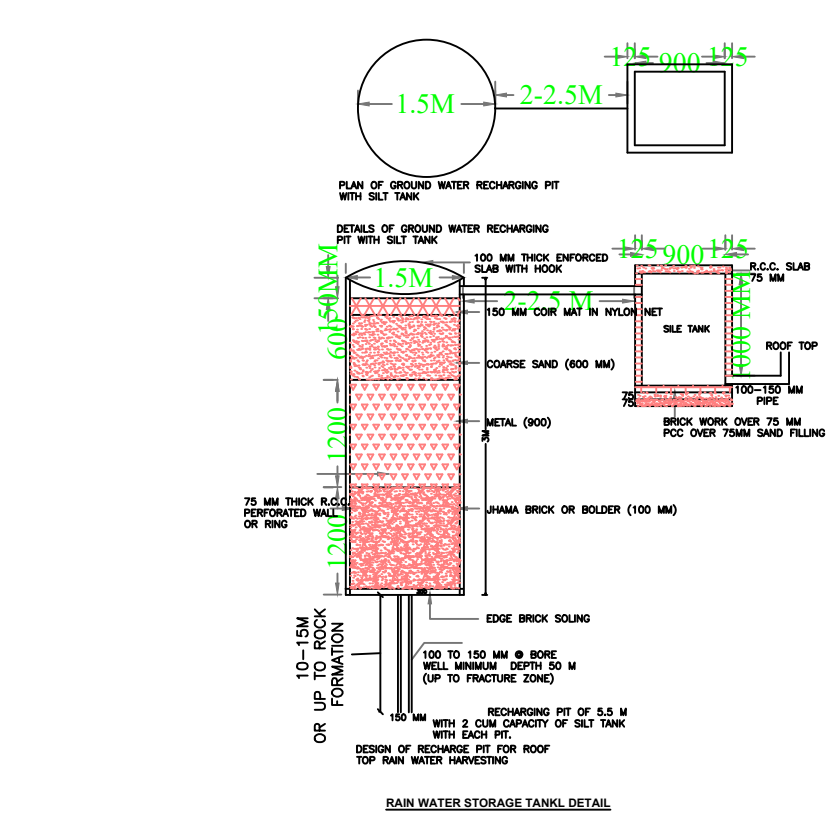

Proposal Basic Information

Proposal File No.	MNNP/BI/0062/W18/2022
Owner Name	Kunj Bihari Singh
Khata No	65
Plot No	872
Village Name	Sudna
Use	Residential
SubUse	Bungalow/ Dwelling / Non Apartment

AREA STATEMENT

AREA DETAILS:		SQ.MT.
AREA OF PLOT (Minimum)	(A)	60.60
Deduction for NetPlot Area		
Surrender Free of Cost		5.67
Total		5.67
NET AREA OF PLOT(Gross Plot Area - Deduction from Gross Plot area)	(A-Deductions)	54.93
Deduction for Balance Plot Area(from Gross Plot Area)		
Surrender Free of Cost		5.67
Common Plot		5.41
Total		11.09
BALANCE AREA OF PLOT(Net Plot Area - Recreational/Amenity space)	(A-Deductions)	49.51
PLOT AREA FOR COVERAGE(Net Plot Area)	(A-Deductions)	54.93
Plot Area for FAR (Net Plot Area + Road/Widening Area)	(A-Deductions)	60.60
COVERAGE CHECK		
Permissible Coverage area ( 70.00 % )		38.45
Proposed Coverage Area ( 58.39 % )		32.07
Total Prop. Coverage Area ( 58.39 % )		32.07
Balance coverage area ( 11.62 % )		6.38
FAR CHECK		
Perm. FAR Area ( 1.20 )		72.72
Total Perm. FAR area		72.72
Residential FAR		64.14
Proposed FAR Area		64.14
Total Proposed FAR Area		64.14
Consumed FAR (Factor)		1.06
Balance FAR Area		8.58
BUILT UP AREA CHECK		
Total Proposed BuiltUp Area		64.14
ARCHITECT (Regd)	RANJIT KUMAR	
ENGINEER (Regd)		
SUPERVISOR (Regd)		
OWNER (Regd)	Kunj Bihari Singh	
DEVELOPMENT AUTHORITY	LOCAL BODY	

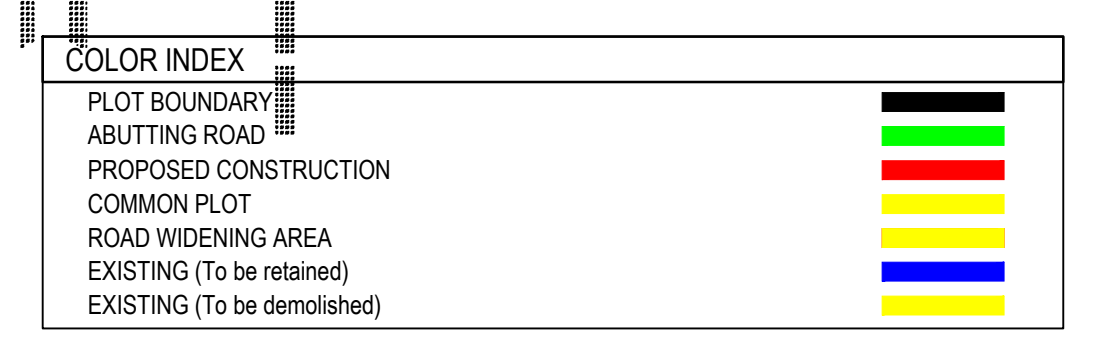

Buildingwise Floor FAR Details

Floor Name	Proposed Built Up Area (Sq.mt.)		Total Proposed Built Up Area (Sq.mt.)	
	Proposed Built Up Area (Sq.mt.)	Proposed FAR Area (Sq.mt.)	Total Proposed Built Up Area (Sq.mt.)	Total FAR Area (Sq.mt.)
Ground Floor	32.07	32.07	32.07	32.07
First Floor	32.07	32.07	32.07	32.07
Terrace Floor	0.00	0.00	0.00	0.00
<b>Total :</b>	<b>64.14</b>	<b>64.14</b>	<b>64.14</b>	<b>64.14</b>

Building USE/SUBUSE Details

Building Name	Building Use	Building SubUse	Building Structure
A (BUILDING)	Residential	Bungalow/ Dwelling / Non Apartment	Non-Highrise



LTP NAME AND SIGNATURE	STRUCTURAL ENG'S NAME AND SIGNATURE	BUILDER NAME AND SIGNATURE	DIGITAL SIGNATURE
RANJIT KUMAR MNNP/ENG/0001/2016			