

SITE PLAN

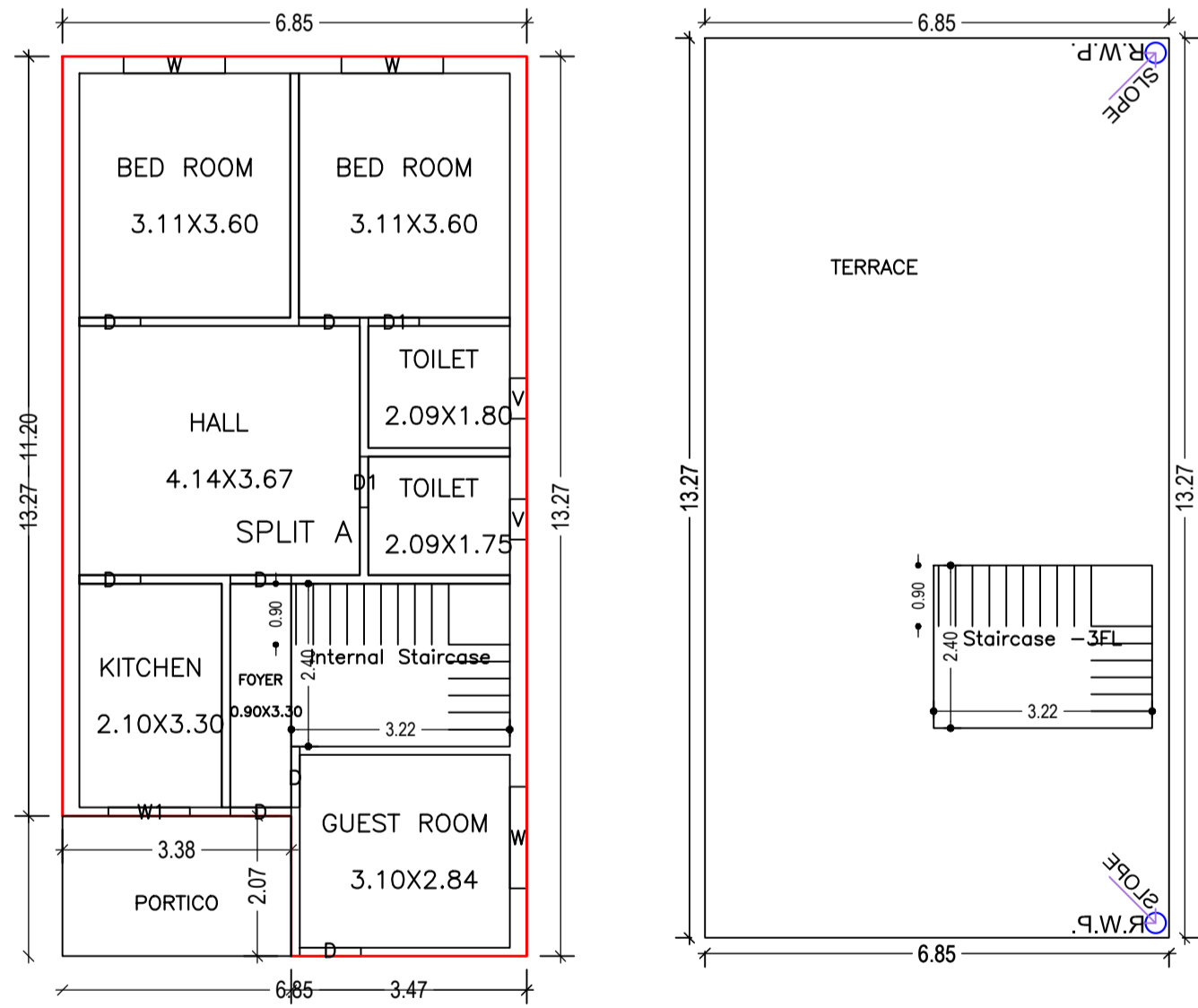

GROUND FLOOR PLAN (Proposed) (SCALE 1:100)

TERRACE FLOOR PLAN (SCALE 1:100)

Floor Name	Total Built Up Area (Sq.mt.)	Deductions (Area in Sq.mt.)	Proposed FAR Area (Sq.mt.)	Total FAR Area (Sq.mt.)	Total Consumed Additional FAR Area (Sq.mt.)	Tnmt (No.)
Ground Floor	90.85	6.98	83.87	83.87	83.87	01
Terrace Floor	0.00	0.00	0.00	0.00	0.00	00
Total :	90.85	6.98	83.87	83.87	83.87	01
Total Number of Same Buildings	1					
Total :	90.85	6.98	83.87	83.87	83.87	01

SCHEDULE OF DOOR:

BUILDING NAME	NAME	LENGTH	HEIGHT	NOS
A (BUILDING)	D1	0.75	2.10	02
A (BUILDING)	D	0.90	2.10	07

SCHEDULE OF WINDOW/VENTILATION:

BUILDING NAME	NAME	LENGTH	HEIGHT	NOS
A (BUILDING)	V	0.60	0.90	02
A (BUILDING)	W1	1.20	1.20	01
A (BUILDING)	W	1.50	1.20	03

UnitBUA Table for Building :A (BUILDING)

FLOOR	Name	UnitBUA Type	UnitBUA Area	Carpet Area	No. of Rooms	No. of Tenement
GROUND FLOOR PLAN	SPLIT A	FLAT	75.11	71.94	8	1
Total:	-	-	75.11	71.94	8	1

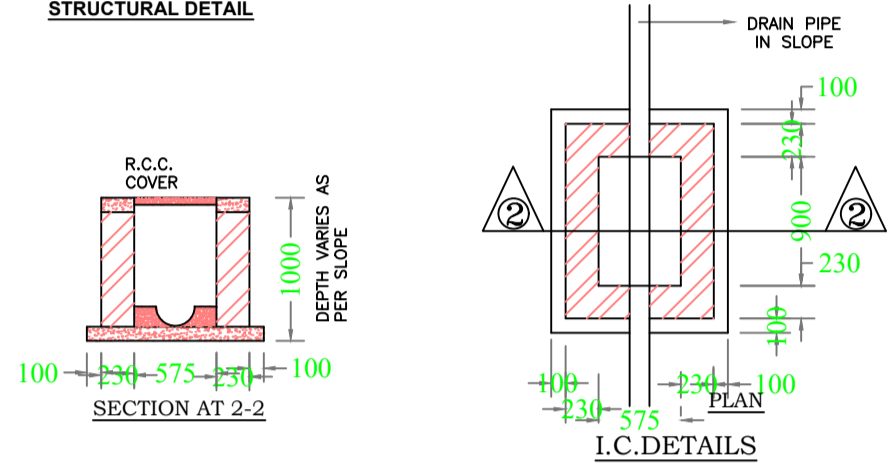
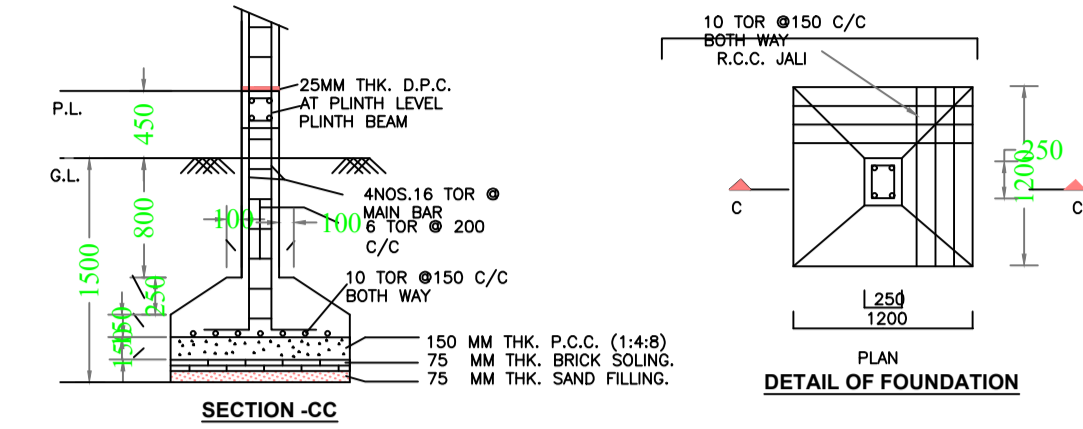

FAR & Tenement Details (Table 4c-1)

Building	No. of Same Bldg	Total Built Up Area (Sq.mt.)	Deductions (Area in Sq.mt.)	Proposed FAR Area (Sq.mt.)	Total FAR Area (Sq.mt.)	Total Consumed Additional FAR Area (Sq.mt.)	Tnmt (No.)
A (BUILDING)	1	90.85	6.98	83.87	83.87	83.87	01
Grand Total:	1	90.85	6.98	83.87	83.87	83.87	01

Proposal Basic Information	
Proposal File No.	MNNP/BI/0087/W18/2022
Owner Name	Sneh Lata Kumari
Khata No	91
Plot No	1758
Village Name	Rodma
Use	Residential
SubUse	Bungalow/ Dwelling / Non Apartment

AREA STATEMENT		VERSION NO. : 1.0.62
MEDININAGAR MUNICIPAL CORPORATION		VERSION DATE: 16/10/2020
PROJECT DETAIL:		
Region: JHARKHAND URBAN LOCAL BODIES	Plot Use: Residential	
District: PALAMU	Plot SubUse: Bungalow/ Dwelling / Non Apartment	
Authority: MEDININAGAR MUNICIPAL CORPORATION	PlotNearbyReligiousStructure: NA	
Inward No: MNNP/BI/0087/W18/2022	Plot/SubPlot No: 1758	
Application Type: General Proposal	North: -	
Project Type: Building Permission	South: -	
Nature of Development: New	East: -	
Location of Development Area: Old Area	West: -	
AREA DETAILS:		
AREA OF PLOT (Minimum)	(A)	141.20
Deduction for NetPlot Area		
Surrender Free of Cost		7.90
Total		7.90
NET AREA OF PLOT(Gross Plot Area - Deduction from Gross Plot area)	(A-Deductions)	133.30
Deduction for Balance Plot Area(from Gross Plot Area)		
Surrender Free of Cost		7.90
Common Plot		12.61
Total		20.51
BALANCE AREA OF PLOT(Net Plot Area - Recreational/Amenity space)	(A-Deductions)	120.69
PLOT AREA FOR COVERAGE(Net Plot Area)	(A-Deductions)	133.30
Plot Area for FAR (Net Plot Area + Road/Widening Area)	(A-Deductions)	141.20
COVERAGE CHECK		
Permissible Coverage area (70.00 %)		93.31
Proposed Coverage Area (62.92 %)		83.87
Total Prop. Coverage Area (62.92 %)		83.87
Balance coverage area (7.08 %)		9.44
FAR CHECK		
Perm. FAR Area (1.20)		169.44
Total Perm. FAR area		169.44
Residential FAR		83.87
Proposed FAR Area		83.87
Total Proposed FAR Area		83.87
Consumed FAR (Factor)		0.59
Balance FAR Area		85.57
BUILT UP AREA CHECK		
Total Proposed BuiltUp Area		90.85
ARCHITECT (Regd)	RANJIT KUMAR	
ENGINEER (Regd)		
SUPERVISOR (Regd)		
OWNER (Regd)	Sneh Lata Kumari	
DEVELOPMENT AUTHORITY		LOCAL BODY

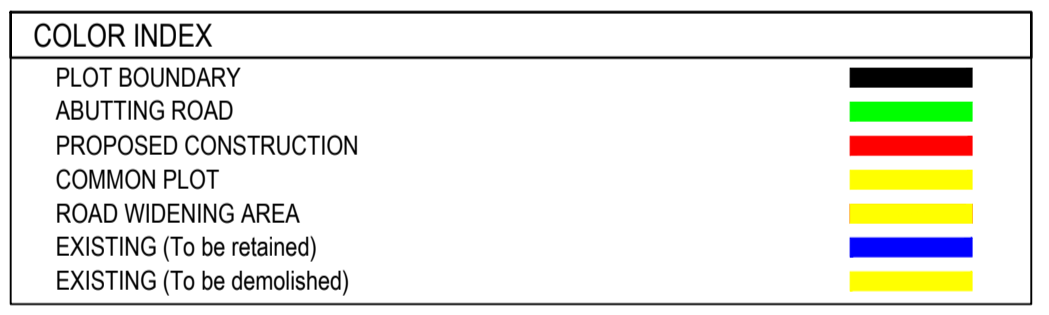

Buildingwise Floor FAR Details

Floor Name	Building Name A (BUILDING)		Total	
	Proposed Built Up Area (Sq.mt.)	Proposed FAR Area (Sq.mt.)	Total Proposed Built Up Area (Sq.mt.)	Total FAR Area (Sq.mt.)
Ground Floor	90.85	83.87	90.85	83.87
Terrace Floor	0.00	0.00	0.00	0.00
Total :	90.85	83.87	90.85	83.87

Building USE/SUBUSE Details

Building Name	Building Use	Building SubUse	Building Structure
A (BUILDING)	Residential	Bungalow/ Dwelling / Non Apartment	Non-Highrise

LTP NAME AND SIGNATURE	STRUCTURAL ENG'S NAME AND SIGNATURE	BUILDER NAME AND SIGNATURE	DIGITAL SIGNATURE
RANJIT KUMAR MNNP/ENG/0001/2016			