

Proposal Basic Information	
Proposal File No.	MNNP/BP/0014/W25/2022
Owner Name	REKHA AGRAWAL
Khata No	0
Plot No	469
Village Name	Kundh
Use	Residential
SubUse	Bungalow/ Dwelling / Non Apartment

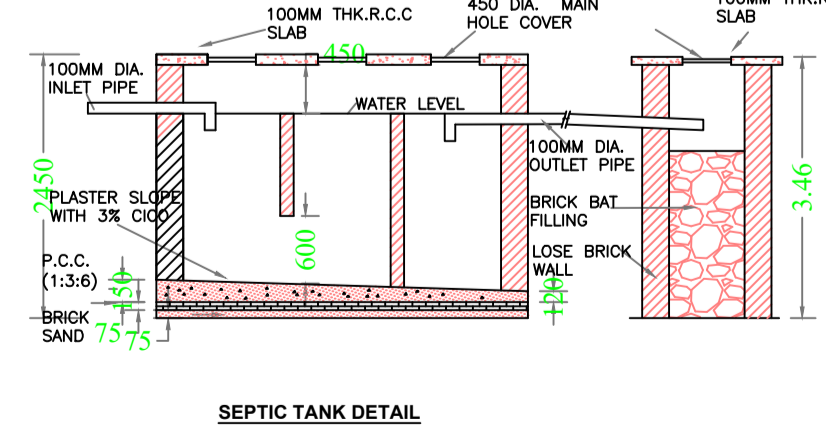
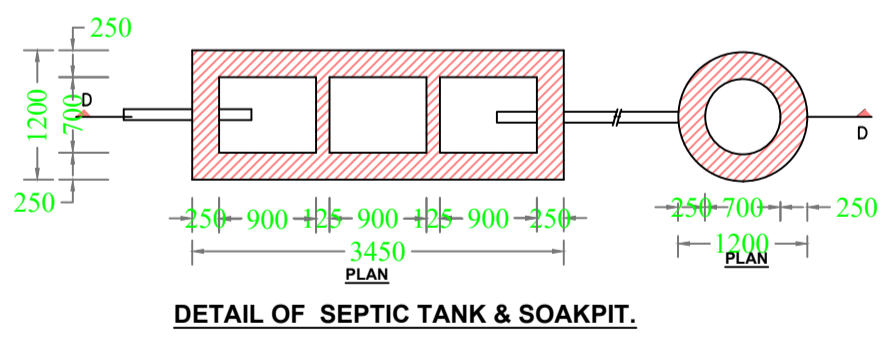
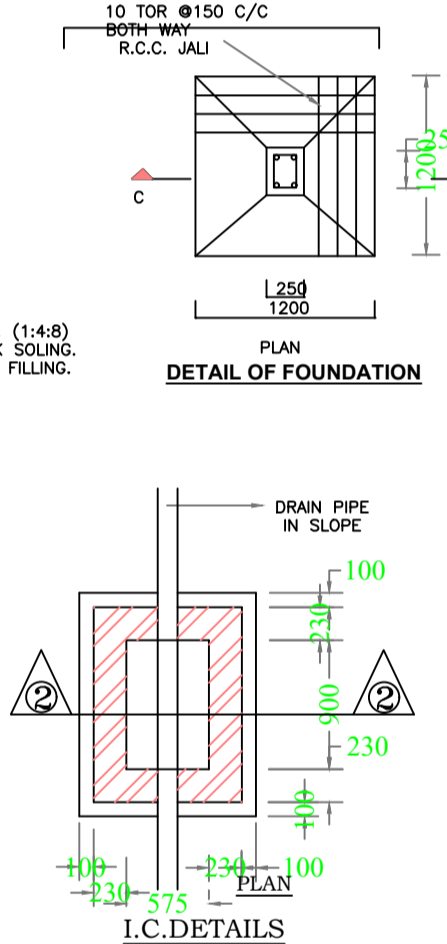
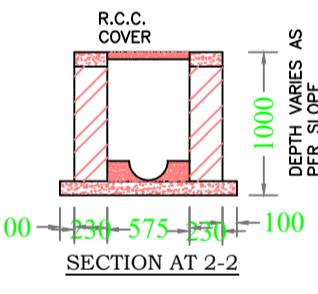
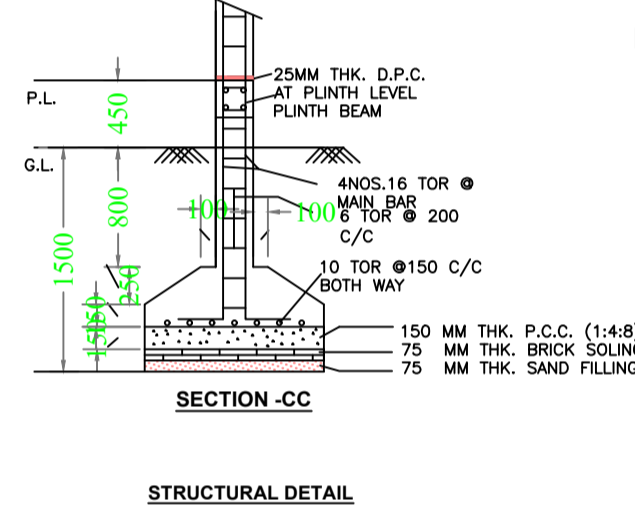
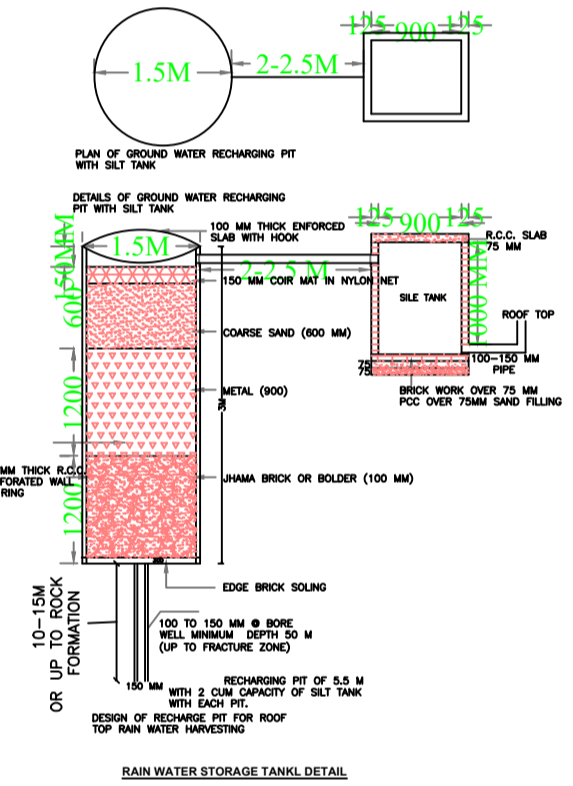
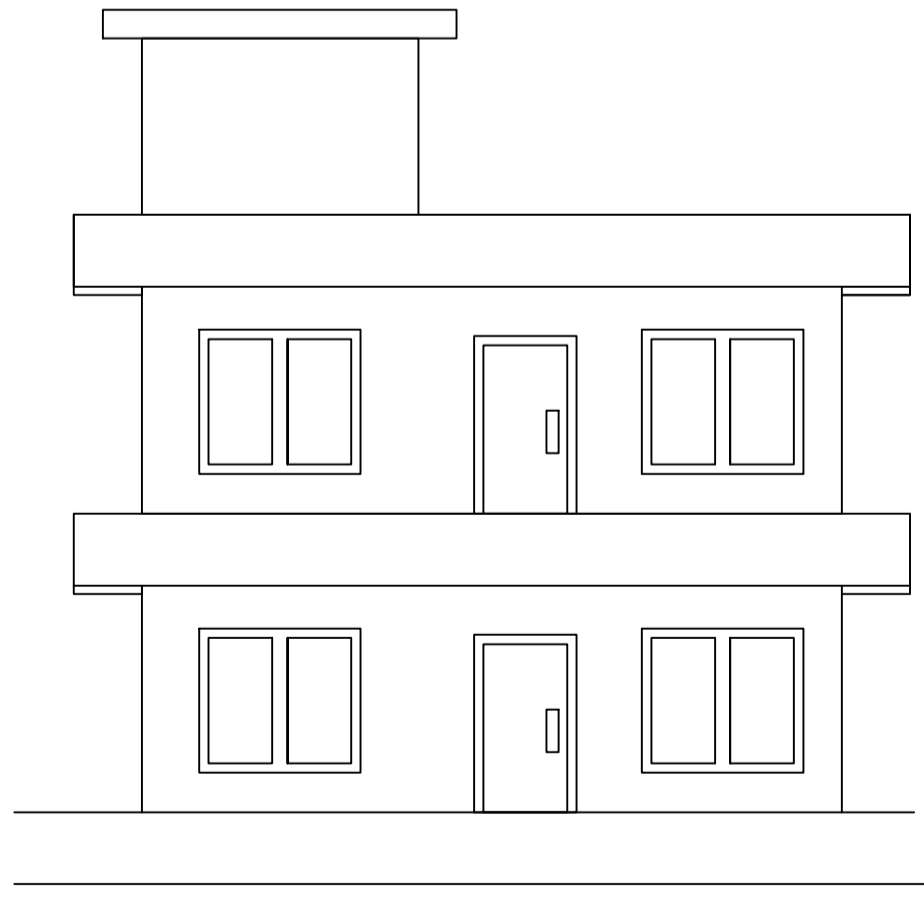
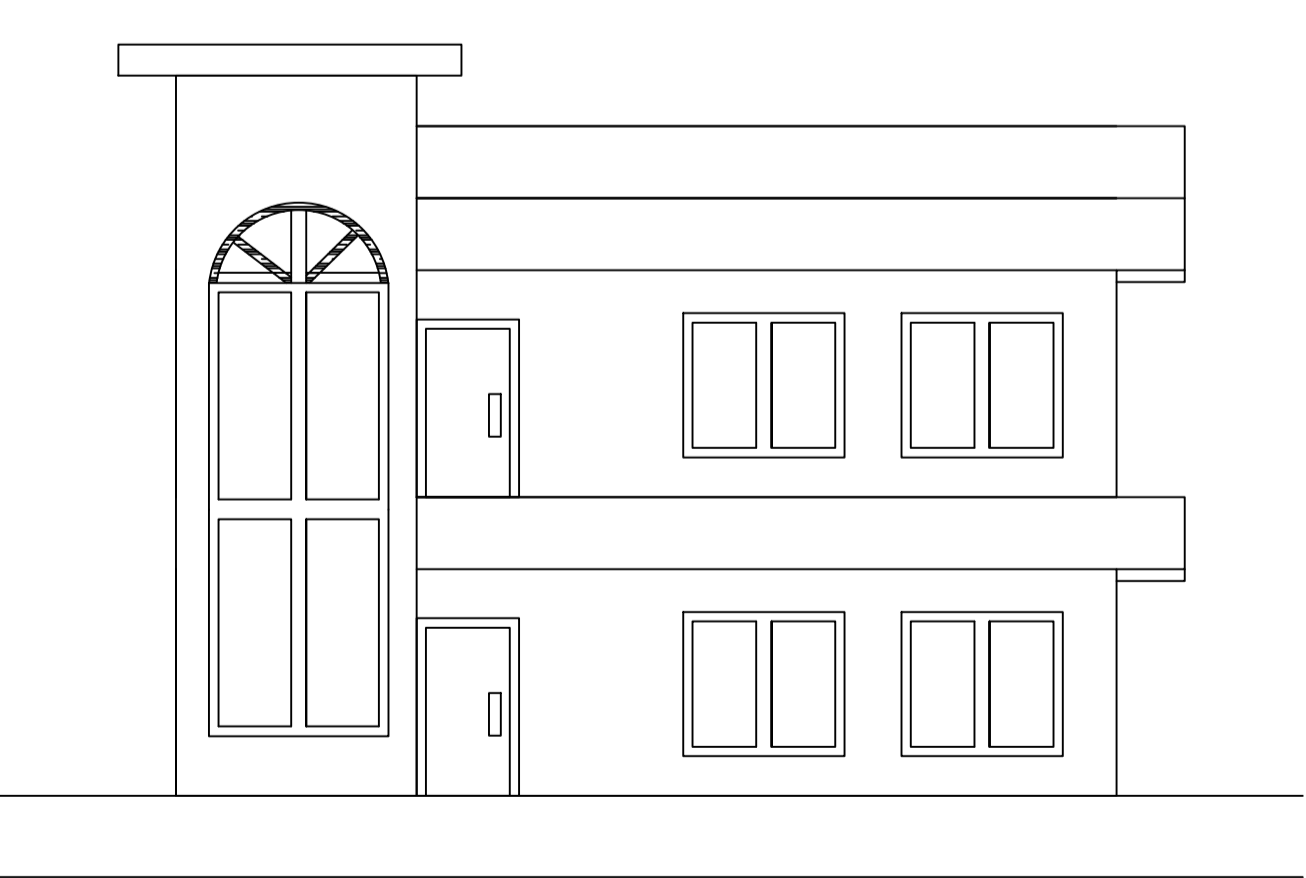
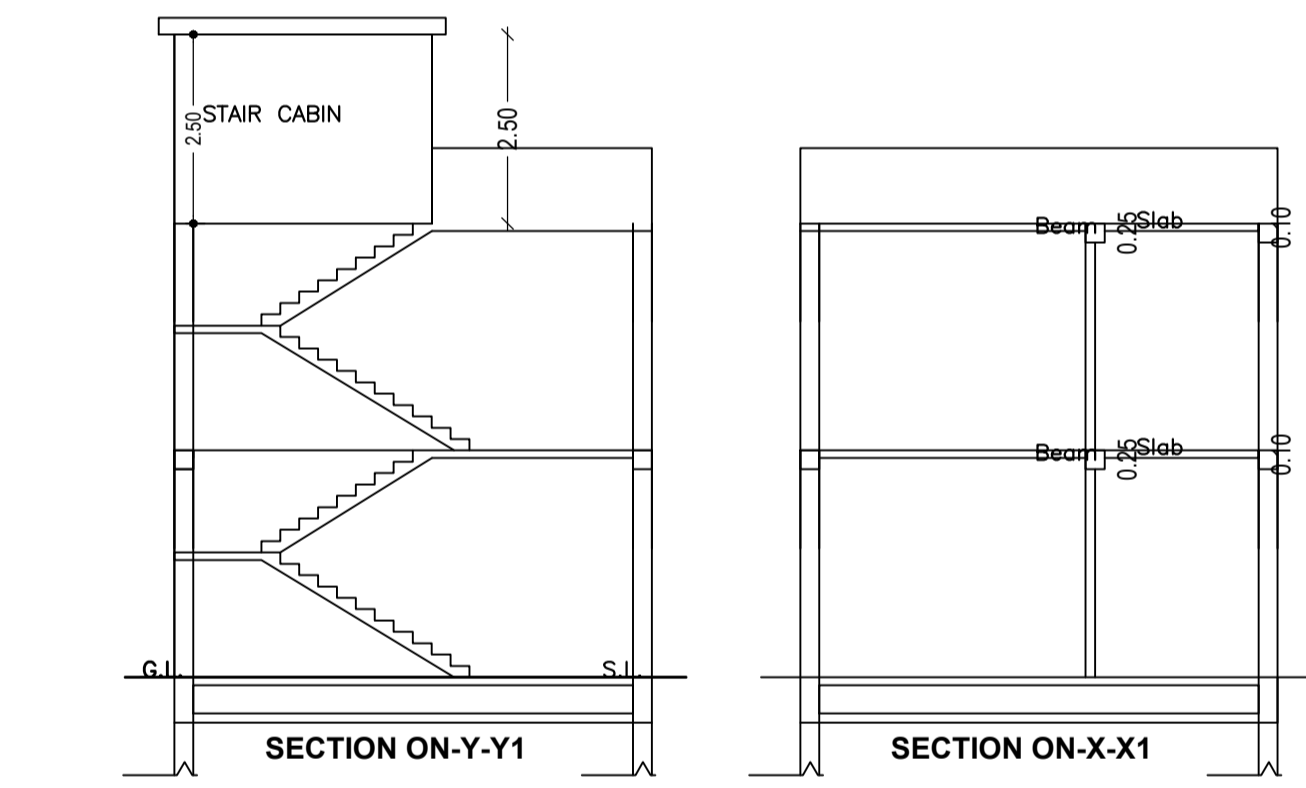
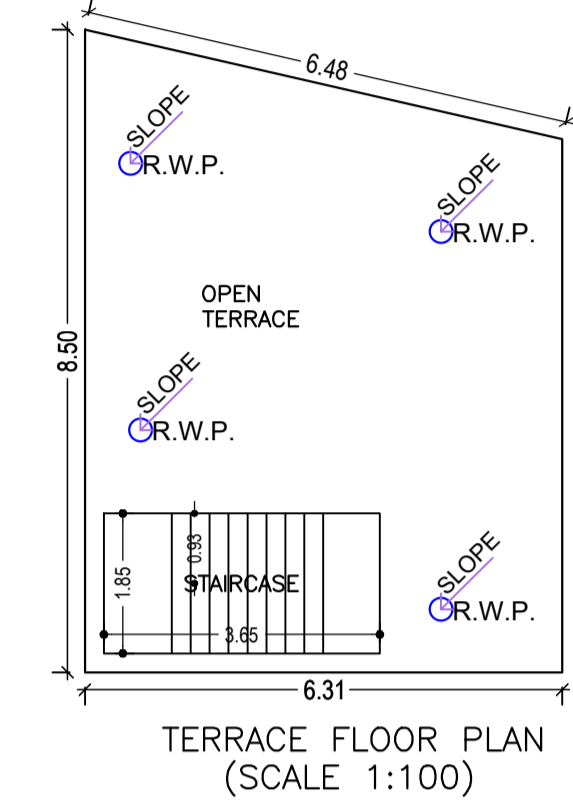
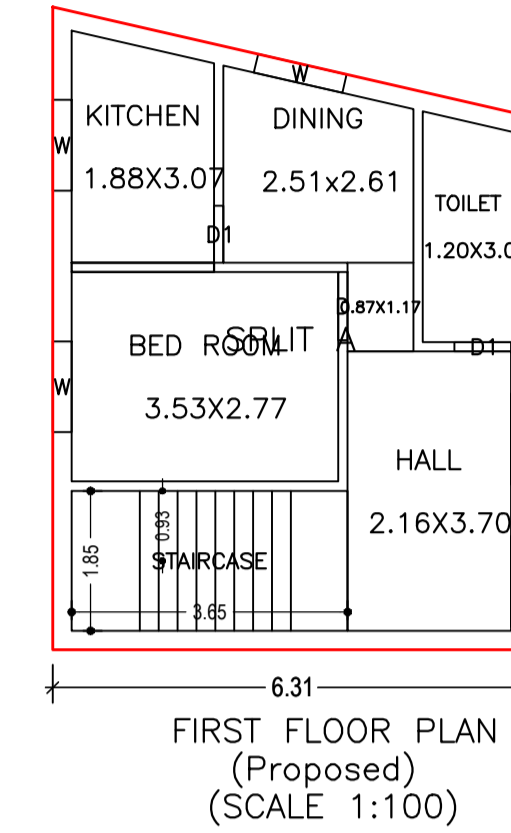
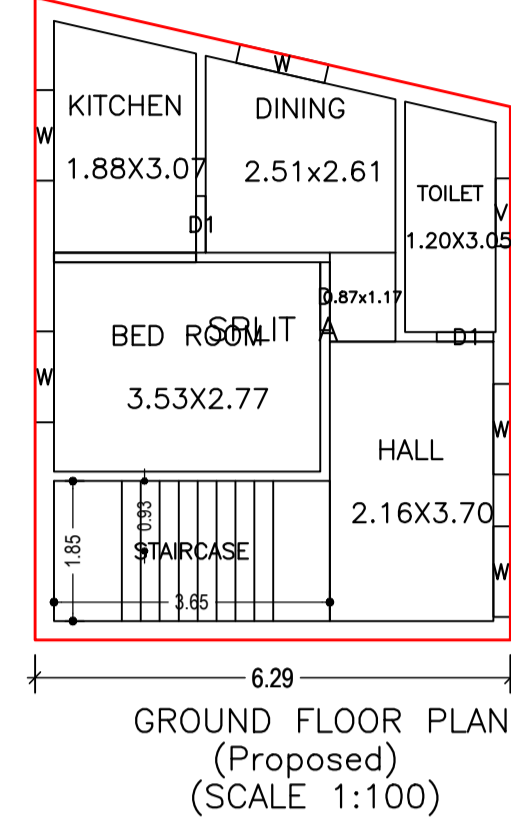
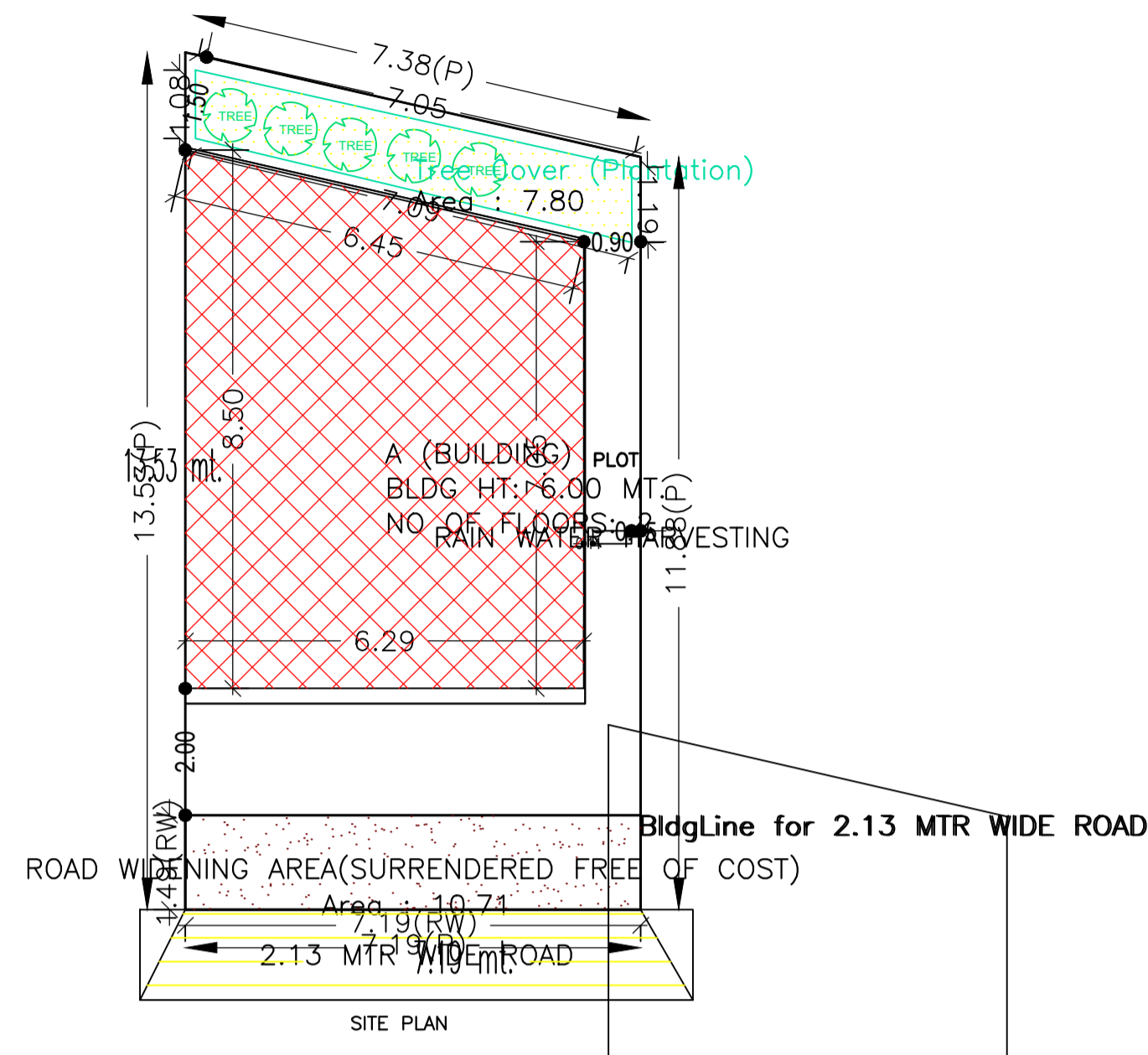

Building :A (BUILDING)

Floor Name	Total Built Up Area (Sq.mt.)	Proposed FAR Area (Sq.mt.) Resi.	Total FAR Area (Sq.mt.)	Total Consumed Additional FAR Area (Sq.mt.)	Trmt (No.)
Ground Floor	48.92	48.92	48.92	48.92	01
First Floor	49.09	49.09	49.09	49.09	00
Terrace Floor	0.00	0.00	0.00	0.00	00
Total :	98.01	98.01	98.01	98.01	01
Total Number of Same Buildings :	1				
Total :	98.01	98.01	98.01	98.01	01

SCHEDULE OF DOOR:

BUILDING NAME	NAME	LENGTH	HEIGHT	NOS
A (BUILDING)	D1	0.75	2.10	04
A (BUILDING)	D	0.90	2.10	02

SCHEDULE OF WINDOW/VENTILATION:

BUILDING NAME	NAME	LENGTH	HEIGHT	NOS
A (BUILDING)	V	0.90	0.60	02
A (BUILDING)	W	1.20	1.20	10

FAR & Tenement Details (Table 4c-1)

Building	No. of Same Bldg	Total Built Up Area (Sq.mt.)	Proposed FAR Area (Sq.mt.) Resi.	Total FAR Area (Sq.mt.)	Total Consumed Additional FAR Area (Sq.mt.)	Trmt (No.)
A (BUILDING)	1	98.01	98.01	98.01	98.01	01
Grand Total :	1	98.01	98.01	98.01	98.01	01

UnitBUA Table for Building :A (BUILDING)

FLOOR	Name	UnitBUA Type	UnitBUA Area	Carpet Area	No. of Rooms	No. of Tenement
GROUND FLOOR PLAN	SPLIT A	FLAT	81.62	81.15	5	1
FIRST FLOOR PLAN	SPLIT A	FLAT	0.00	0.00	5	0
Total:	-	-	81.62	81.15	10	1

AREA STATEMENT		VERSION NO. : 1.0.62
MEDINAGAR MUNICIPAL CORPORATION		VERSION DATE: 16/10/2020
PROJECT DETAIL:		
Region: JHARKHAND URBAN LOCAL BODIES	Plot Use: Residential	
District: PALAMU	Plot SubUse: Bungalow/ Dwelling / Non Apartment	
Authority: MEDINAGAR MUNICIPAL CORPORATION	PlotNearby/ReligiousStructure: NA	
Inward_No: MNNP/BP/0014/W25/2022	Plot/SubPlot No: 469	
Application Type: General Proposal	North: -	
Project Type: Building Permission	South: -	
Nature of Development: New	East: -	
Location of Development Area: Old Area	West: -	
AREA DETAILS:		
AREA OF PLOT (Minimum)	(A)	90.90 SQ.MT.
Deduction for NetPlot Area		
Surrender Free of Cost		10.71
Total		10.71
NET AREA OF PLOT(Gross Plot Area - Deduction from Gross Plot area)	(A-Deductions)	80.19
Deduction for Balance Plot Area(from Gross Plot Area)		
Surrender Free of Cost		10.71
Common Plot		7.80
Total		18.51
BALANCE AREA OF PLOT(Net Plot Area - Recreational/Amenity space)	(A-Deductions)	72.39
PLOT AREA FOR COVERAGE(Net Plot Area)	(A-Deductions)	80.19
Plot Area for FAR (Net Plot Area + RoadWidening Area)	(A-Deductions)	90.90
COVERAGE CHECK		
Permissible Coverage area (70.00 %)		56.13
Proposed Coverage Area (61.01 %)		48.92
Total Prop. Coverage Area (61.01 %)		48.92
Balance coverage area (8.99 %)		7.21
FAR CHECK		
Perm. FAR Area (1.20)		109.08
Total Perm. FAR area		109.08
Residential FAR		98.01
Proposed FAR Area		98.01
Total Proposed FAR Area		98.01
Consumed FAR (Factor)		1.08
Balance FAR Area		11.07
BUILT UP AREA CHECK		
Total Proposed BuiltUp Area		98.01
ARCHITECT (Regd)		RANJIT KUMAR
ENGINEER (Regd)		
SUPERVISOR (Regd)		
OWNER (Regd)		REKHA AGRAWAL
DEVELOPMENT AUTHORITY		LOCAL BODY

COLOR INDEX	
PLOT BOUNDARY	Black
ABUTTING ROAD	Red
PROPOSED CONSTRUCTION	Green
COMMON PLOT	Yellow
ROAD WIDENING AREA	Blue
EXISTING (To be retained)	Orange
EXISTING (To be demolished)	Pink

Buildingwise Floor FAR Details

Floor Name	Building Name		Total	
	Proposed Built Up Area (Sq.mt.)	Proposed FAR Area (Sq.mt.)	Total Proposed Built Up Area (Sq.mt.)	Total FAR Area (Sq.mt.)
Ground Floor	48.92	48.92	48.92	48.92
First Floor	49.09	49.09	49.09	49.09
Terrace Floor	0.00	0.00	0.00	0.00
Total :	98.01	98.01	98.01	98.01

Building USE/SUBUSE Details

Building Name	Building Use	Building SubUse	Building Structure
A (BUILDING)	Residential	Bungalow/ Dwelling / Non Apartment	Non-Highrise

LTP NAME AND SIGNATURE	STRUCTURAL ENG'S NAME AND SIGNATURE	BUILDER NAME AND SIGNATURE	DIGITAL SIGNATURE
RANJIT KUMAR MNNP/ENG/0001/2016			