

FAR & Tenement Details (Table 4c-1)

Building	No. of Same Bldg	Total Built Up Area (Sq.mt.)	Proposed FAR Area (Sq.mt.) Resi.	Total FAR Area (Sq.mt.)	Total Consumed Additional FAR Area (Sq.mt.)	Tnmt (No.)
A (RESIDENTIAL)	1	155.24	155.24	155.24	155.24	01
Grand Total :	1	155.24	155.24	155.24	155.24	01

Proposal Basic Information

Proposal File No.	MNNP/BP/0198/W03/2022
Owner Name	Alkh Niranjn VERNA
Khata No	1
Plot No	1309,1320
Village Name	Nabatoli
Use	Residential
SubUse	Bungalow/ Dwelling / Non Apartment

AREA STATEMENT	VERSION NO. : 1.0.62
MEDININAGAR MUNICIPAL CORPORATION	VERSION DATE: 16/10/2020
PROJECT DETAIL:	
Region: JHARKHAND URBAN LOCAL BODIES	Plot Use: Residential
District: PALAMU	Plot SubUse: Bungalow/ Dwelling / Non Apartment
Authority: MEDININAGAR MUNICIPAL CORPORATION	PlotNearbyReligiousStructure: NA
Inward No: MNNP/BP/0198/W03/2022	Plot/SubPlot No: 1309,1320
Application Type: General Proposal	North: -
Project Type: Building Permission	South: -
Nature of Development: New	East: -
Location of Development Area: Old Area	West: -
AREA DETAILS:	
AREA OF PLOT (Minimum)	(A) 156.30
Deduction for NetPlot Area	
Surrender Free of Cost	16.02
Total	16.02
NET AREA OF PLOT(Gross Plot Area - Deduction from Gross Plot area)	(A-Deductions) 140.28
Deduction for Balance Plot Area(from Gross Plot Area)	
Surrender Free of Cost	16.02
Common Plot	22.43
Total	38.46
BALANCE AREA OF PLOT(Net Plot Area - Recreational/Amenity space)	(A-Deductions) 117.84
PLOT AREA FOR COVERAGE(Net Plot Area)	(A-Deductions) 140.28
Plot Area for FAR (Net Plot Area + Road/Widening Area)	(A-Deductions) 156.30
COVERAGE CHECK	
Permissible Coverage area (70.00 %)	98.20
Proposed Coverage Area (55.33 %)	77.62
Total Prop. Coverage Area (55.33 %)	77.62
Balance coverage area (14.67 %)	20.58
FAR CHECK	
Perm. FAR Area (1.20)	187.56
Total Perm. FAR area	187.56
Residential FAR	155.25
Proposed FAR Area	155.25
Total Proposed FAR Area	155.25
Consumed FAR (Factor)	0.99
Balance FAR Area	32.31
BUILT UP AREA CHECK	
Total Proposed BuiltUp Area	155.24
ARCHITECT (Regd)	RANJIT KUMAR
ENGINEER (Regd)	
SUPERVISOR (Regd)	
OWNER (Regd)	Alkh Niranjn VERNA
DEVELOPMENT AUTHORITY	LOCAL BODY

COLOR INDEX

PLOT BOUNDARY	Black
ABUTTING ROAD	Green
PROPOSED CONSTRUCTION	Red
COMMON PLOT	Yellow
ROAD WIDENING AREA	Blue
EXISTING (To be retained)	Light Blue
EXISTING (To be demolished)	Orange

Buildingwise Floor FAR Details

Floor Name	Building Name A (RESIDENTIAL)		Total	
	Proposed Built Up Area (Sq.mt.)	Proposed FAR Area (Sq.mt.)	Total Proposed Built Up Area (Sq.mt.)	Total FAR Area (Sq.mt.)
Ground Floor	77.62	77.62	77.62	77.62
First Floor	77.62	77.62	77.62	77.62
Terrace Floor	0.00	0.00	0.00	0.00
Total :	155.24	155.24	155.24	155.24

Building USE/SUBUSE Details

Building Name	Building Use	Building SubUse	Building Structure
A (RESIDENTIAL)	Residential	Bungalow/ Dwelling / Non Apartment	Non-Highrise

LTP NAME AND SIGNATURE	STRUCTURAL ENG'S NAME AND SIGNATURE	BUILDER NAME AND SIGNATURE	DIGITAL SIGNATURE
RANJIT KUMAR MNNP/ENG/0001/2016			

Proposal Basic Information

Proposal File No.	MNNP/BI/0198/W03/2022
Owner Name	Alkh Niranjn VERNA
Khata No	1
Plot No	1309,1320
Village Name	Nabatoli
Use	Residential
SubUse	Bungalow/ Dwelling / Non Apartment

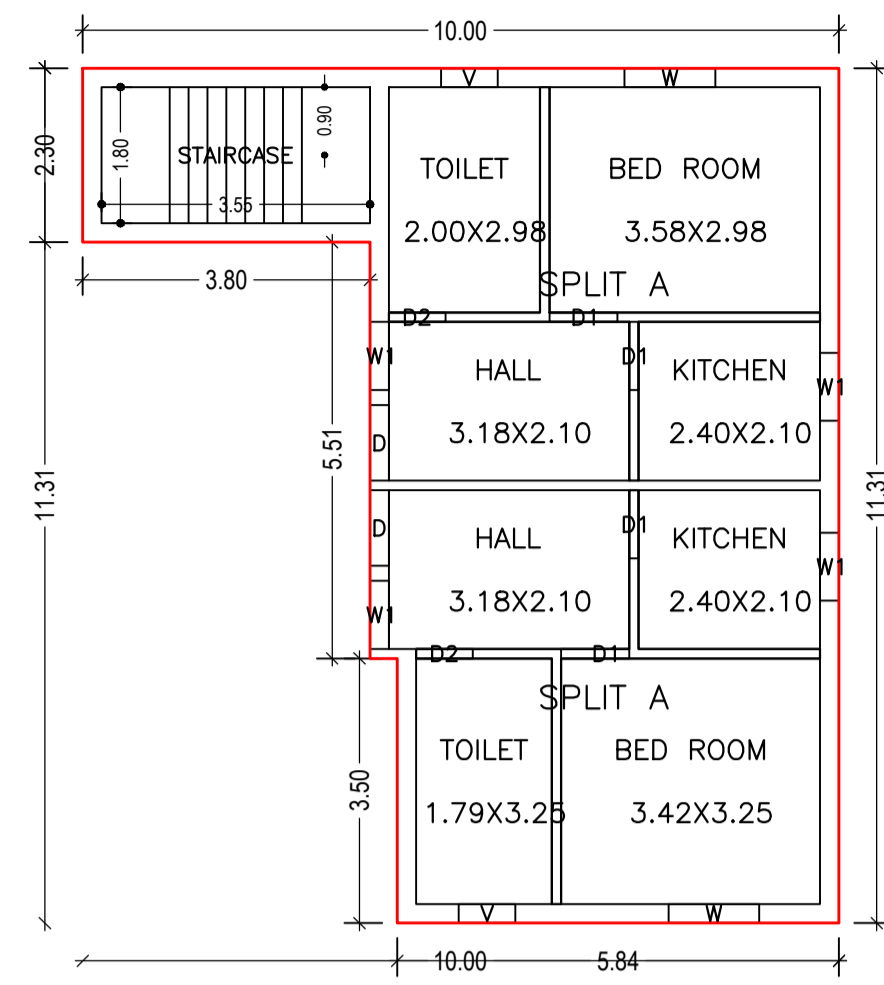

GROUND FLOOR PLAN (Proposed) (SCALE 1:100)

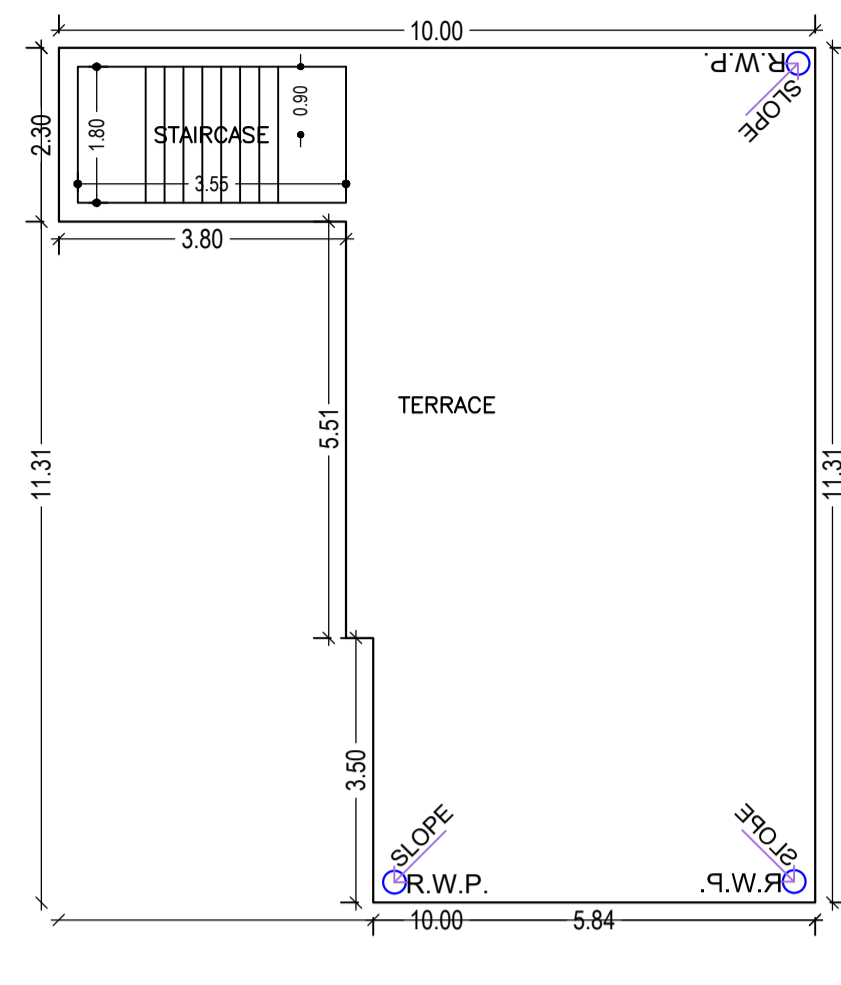

TERRACE FLOOR PLAN (SCALE 1:100)

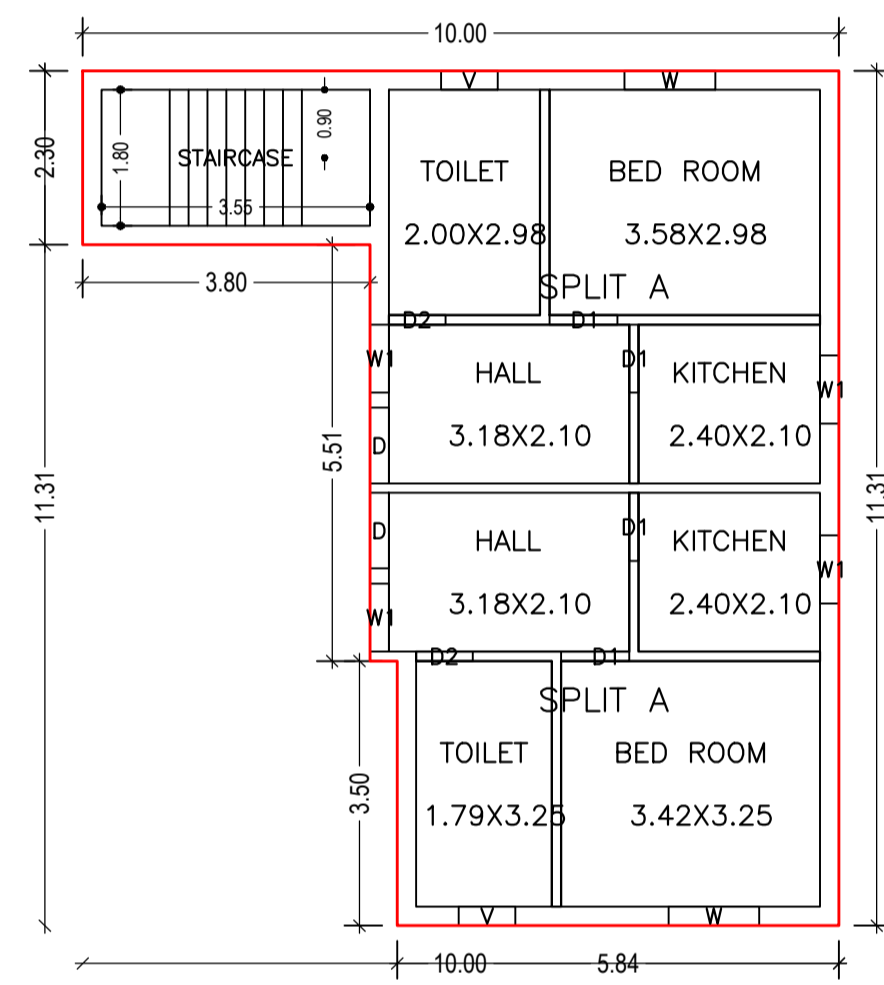

FIRST FLOOR PLAN (Proposed) (SCALE 1:100)

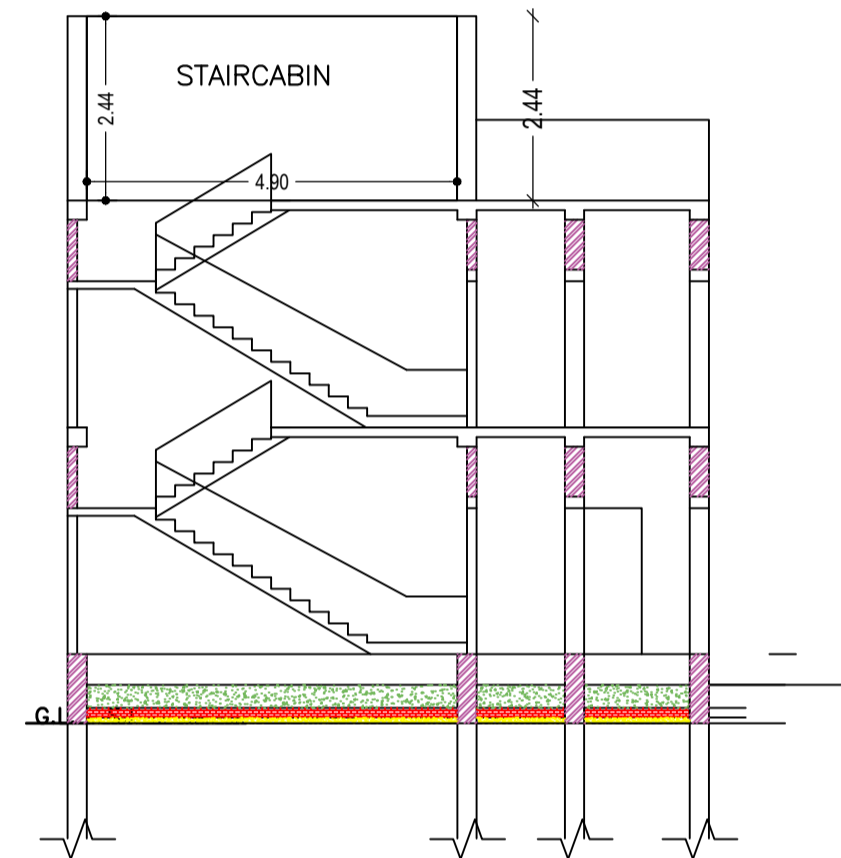

CROSS SECTION (A)

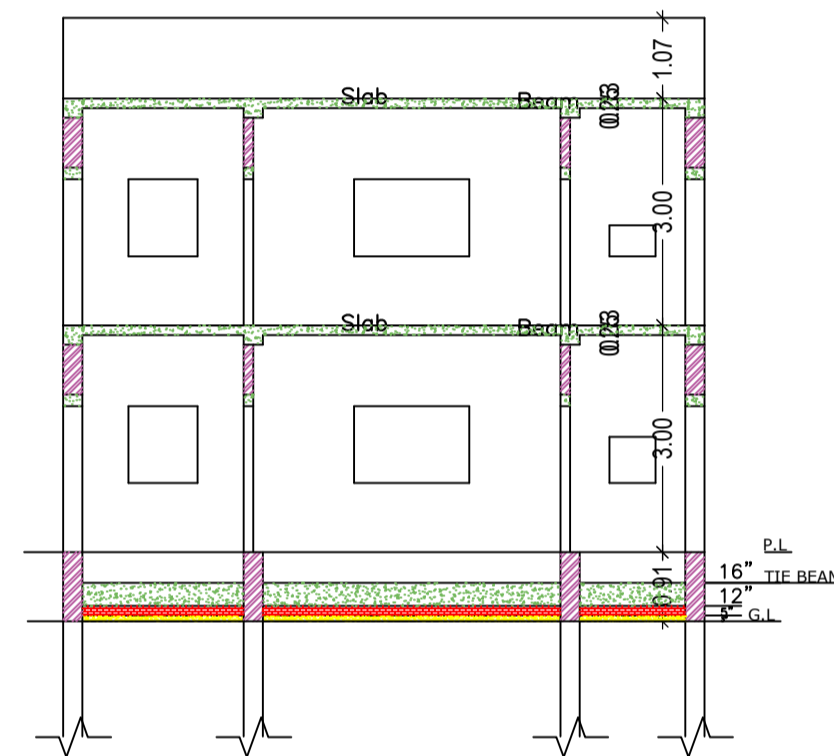

CROSS SECTION (B)

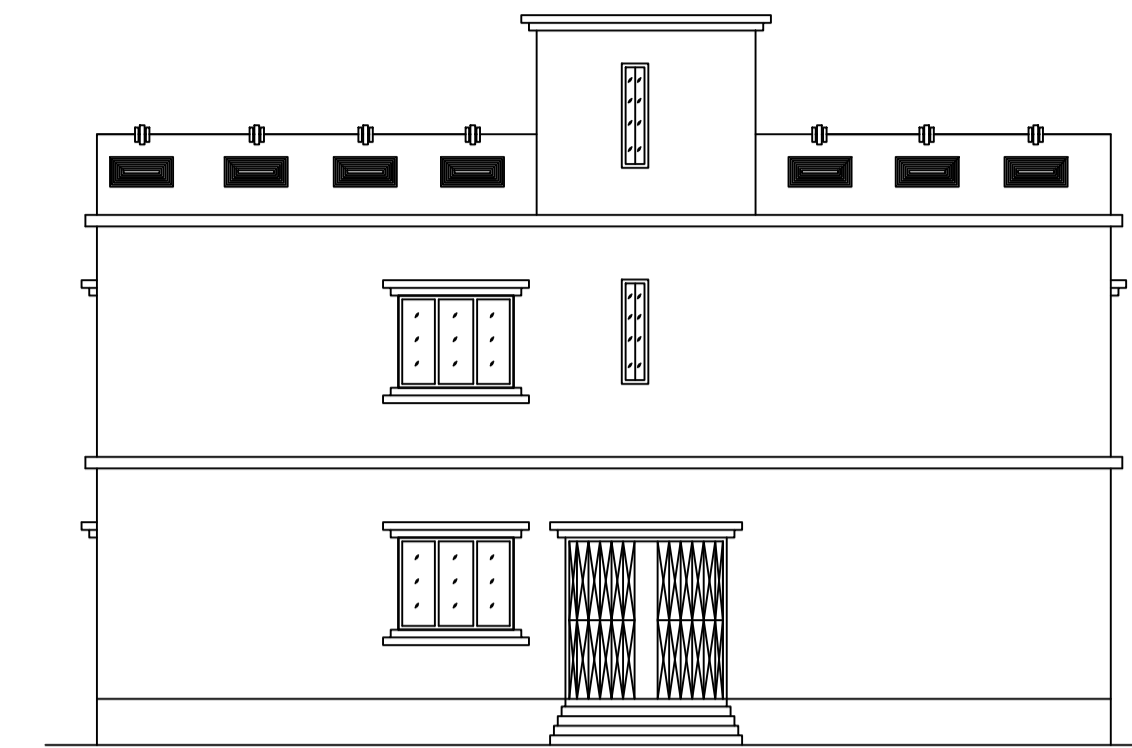

CROSS ELEVATION

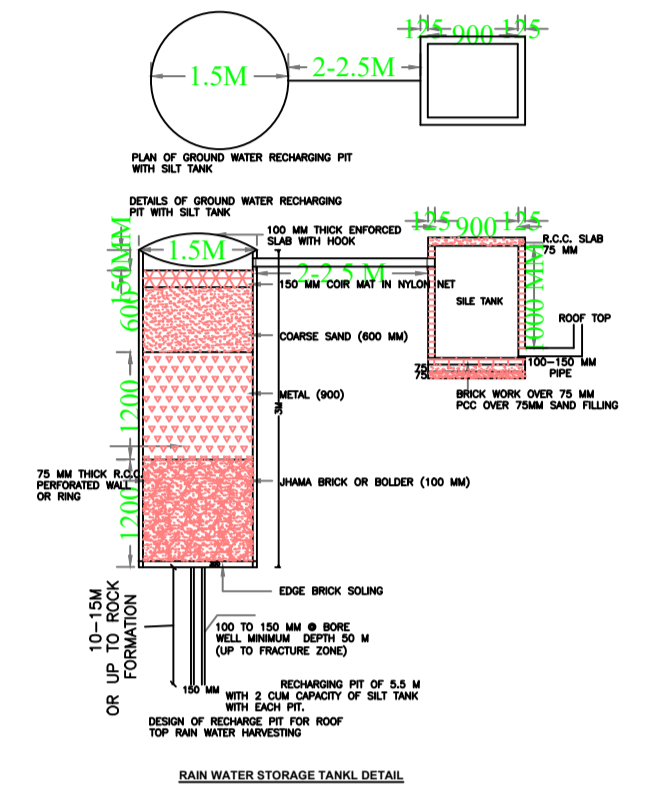

RAIN WATER STORAGE TANK DETAIL

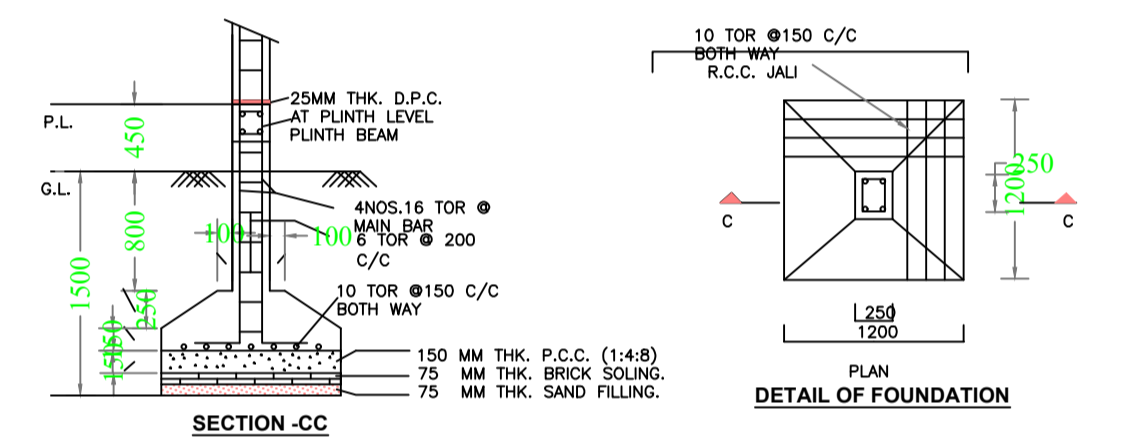

SECTION -CC

DETAIL OF FOUNDATION

STRUCTURAL DETAIL

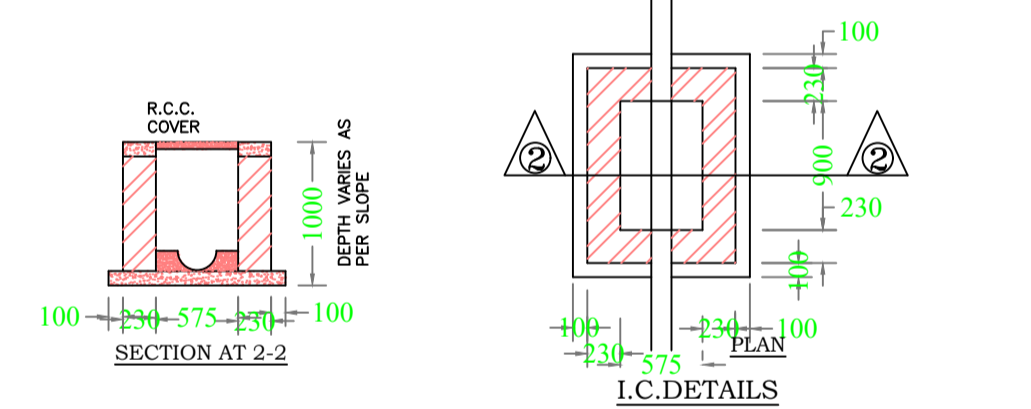

SECTION AT 2-2

I.C. DETAILS

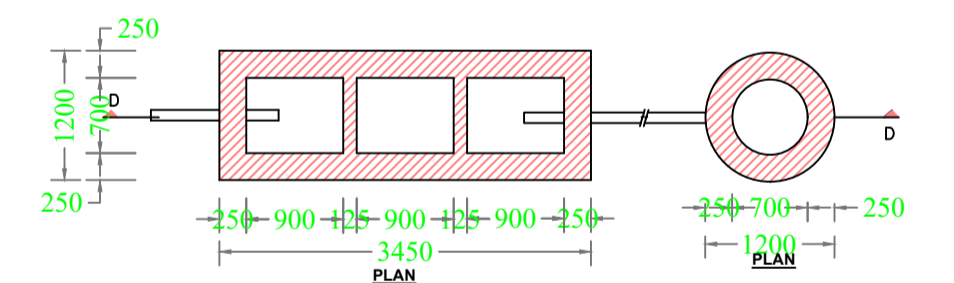

DETAIL OF SEPTIC TANK & SOAKPIT.

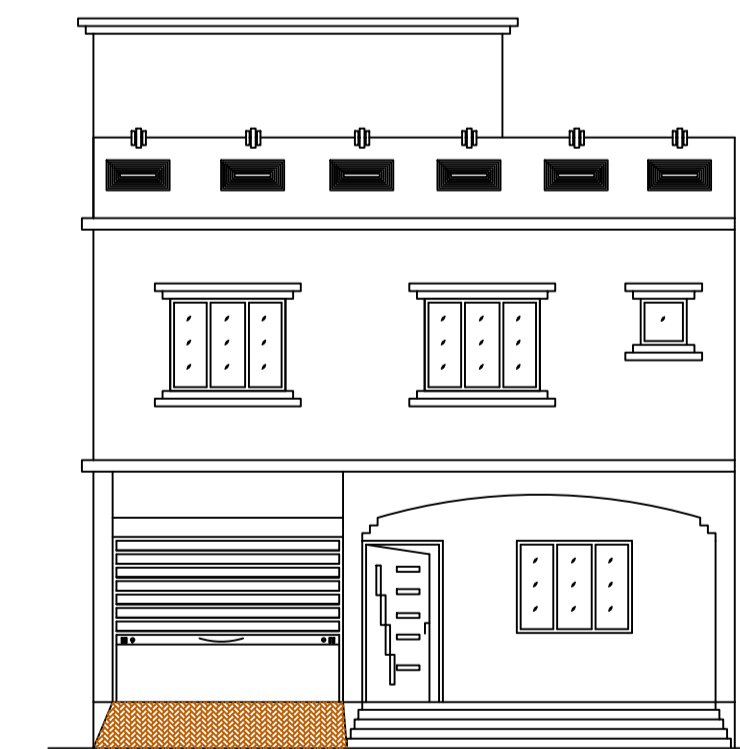

FRONT ELEVATION

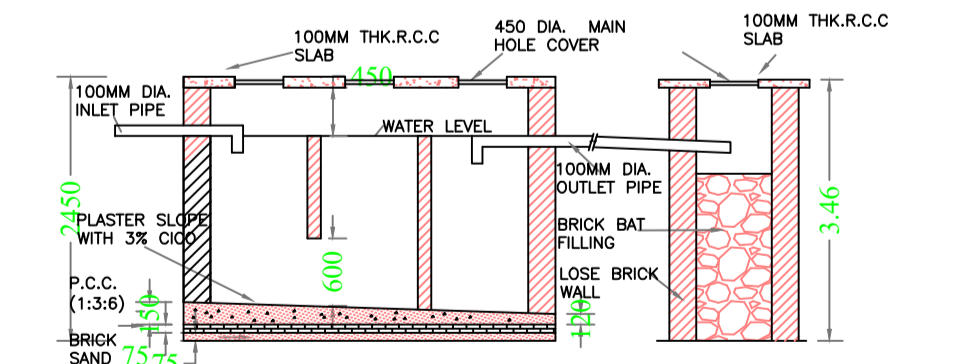

SEPTIC TANK DETAIL

Building :A (RESIDENTIAL)

Floor Name	Total Built Up Area (Sq.mt.)	Proposed FAR Area (Sq.mt.)	Total FAR Area (Sq.mt.)	Total Consumed Additional FAR Area (Sq.mt.)	Tnmt (No.)
Ground Floor	77.62	77.62	77.62	77.62	01
First Floor	77.62	77.62	77.62	77.62	00
Terrace Floor	0.00	0.00	0.00	0.00	00
Total :	155.24	155.24	155.24	155.24	01
Total Number of Same Buildings	1				
Total :	155.24	155.24	155.24	155.24	01

SCHEDULE OF DOOR:

BUILDING NAME	NAME	LENGTH	HEIGHT	NOS
A (RESIDENTIAL)	D2	0.75	2.10	04
A (RESIDENTIAL)	D1	0.90	2.10	08
A (RESIDENTIAL)	D	1.00	2.10	04

SCHEDULE OF WINDOW/VENTILATION:

BUILDING NAME	NAME	LENGTH	HEIGHT	NOS
A (RESIDENTIAL)	V	0.75	0.90	04
A (RESIDENTIAL)	W1	0.90	1.20	08
A (RESIDENTIAL)	W	1.20	1.20	04

UnitBUA Table for Building :A (RESIDENTIAL)

FLOOR	Name	UnitBUA Type	UnitBUA Area	Carpet Area	No. of Rooms	No. of Tenement
GROUND	SPLIT A	FLAT	119.42	114.05	4	1
FLOOR PLAN	SPLIT A	FLAT	0.00	0.00	4	0
FIRST FLOOR PLAN	SPLIT A	FLAT	0.00	0.00	4	0
Total:	-	-	119.42	114.05	16	1

LTP NAME AND SIGNATURE	STRUCTURAL ENG'S NAME AND SIGNATURE	BUILDER NAME AND SIGNATURE	DIGITAL SIGNATURE
RANJIT KUMAR MNNP/ENG/0001/2016			