

Proposal Basic Information

Proposal File No.	MNNP/BJP/0215/W03/2022
Owner Name	Reshmi Devi
Khata No	34
Plot No	282
Village Name	Sudna
Use	Residential
SubUse	Bungalow/ Dwelling / Non Apartment

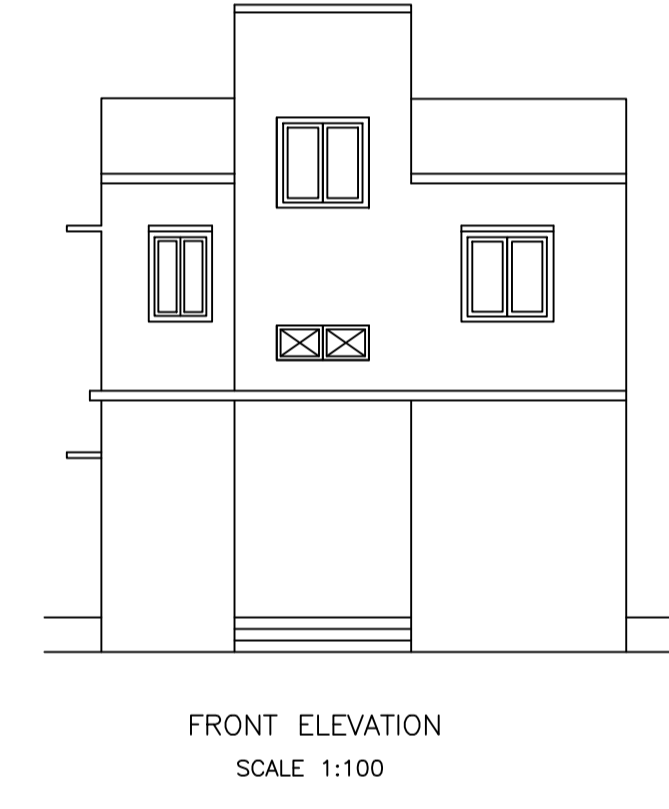
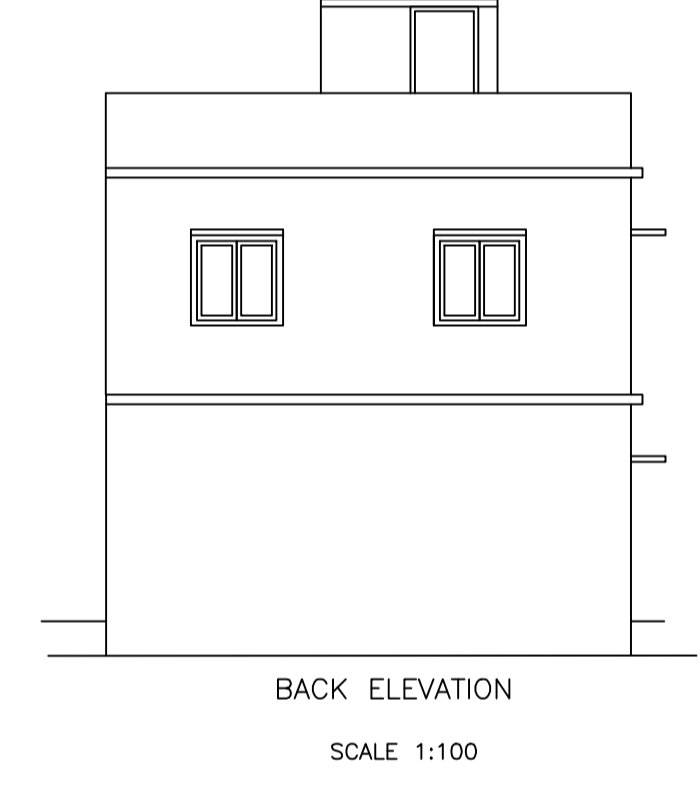
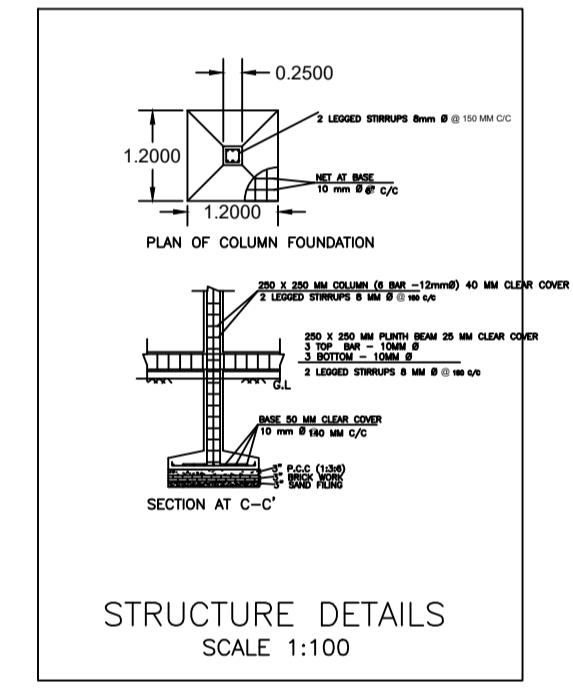
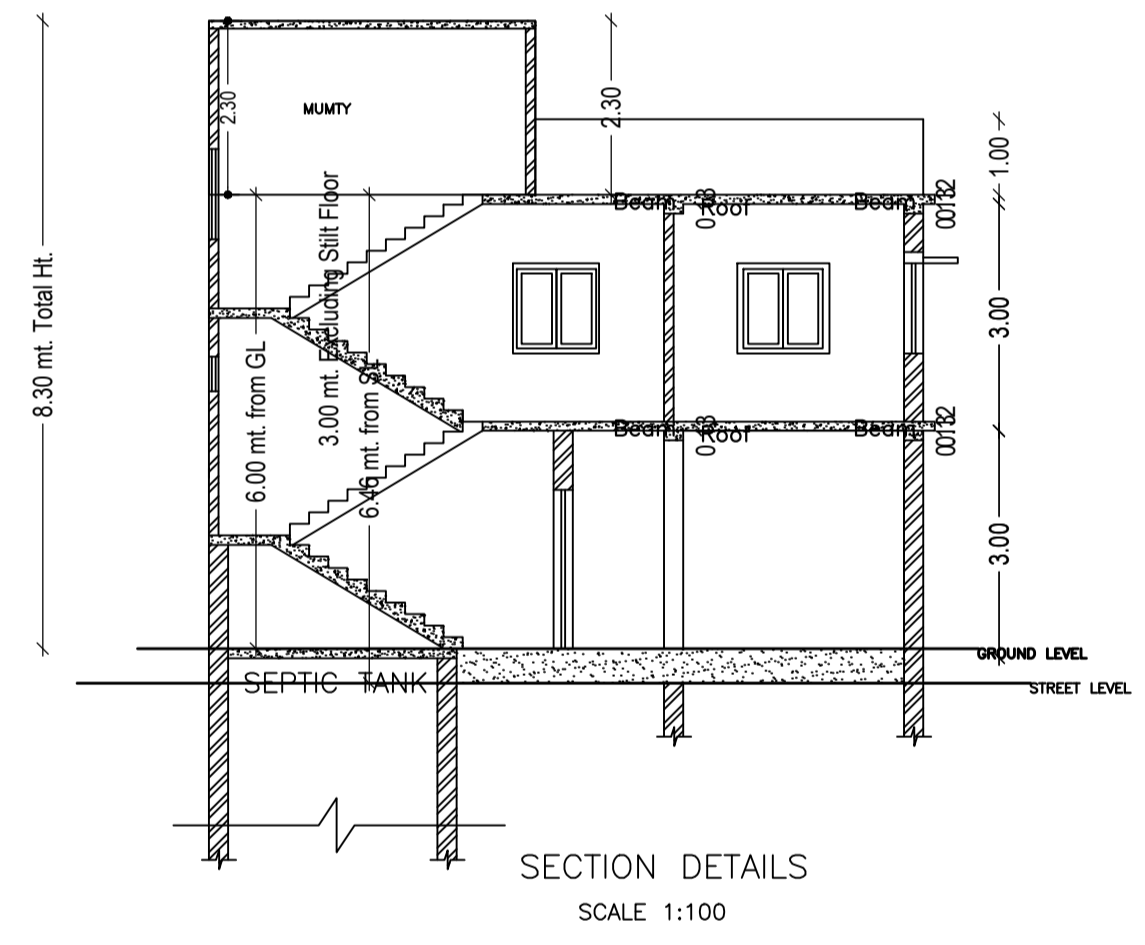
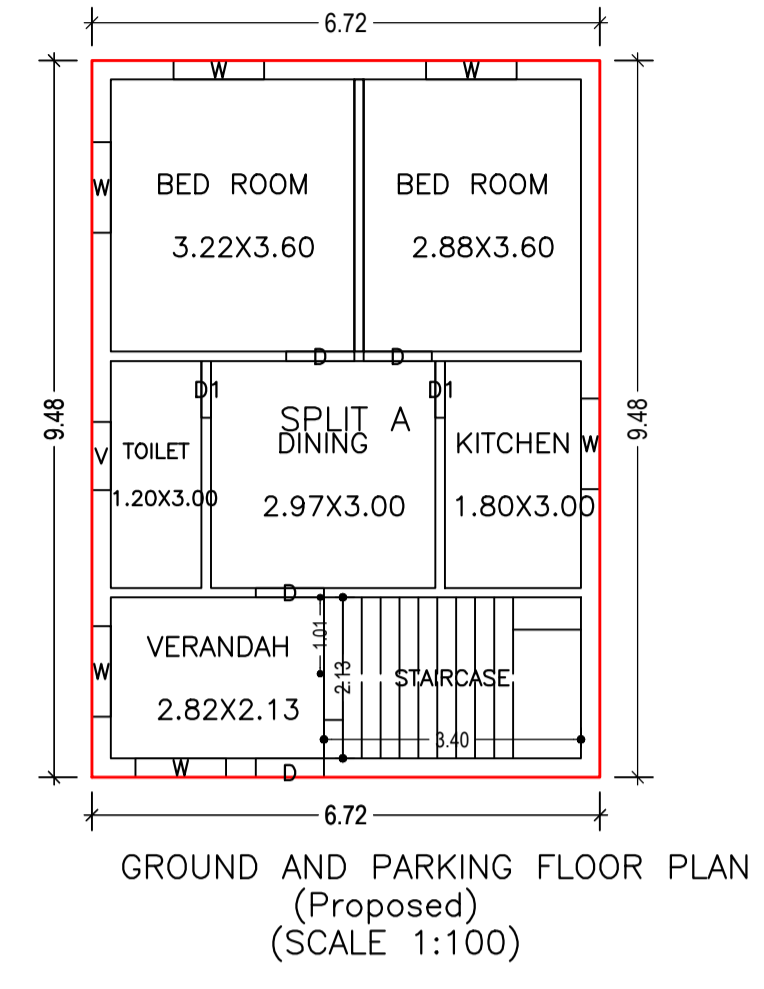
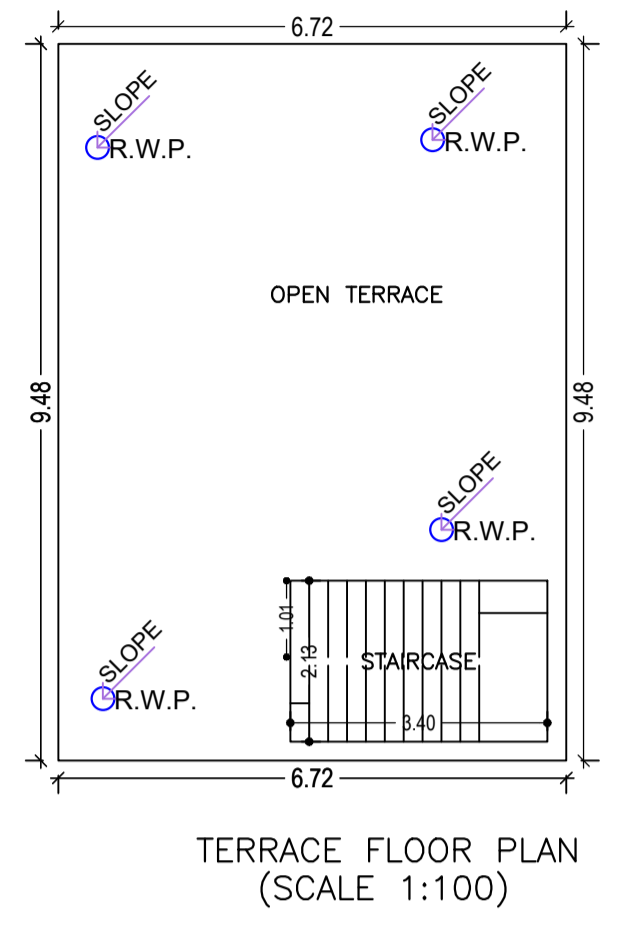
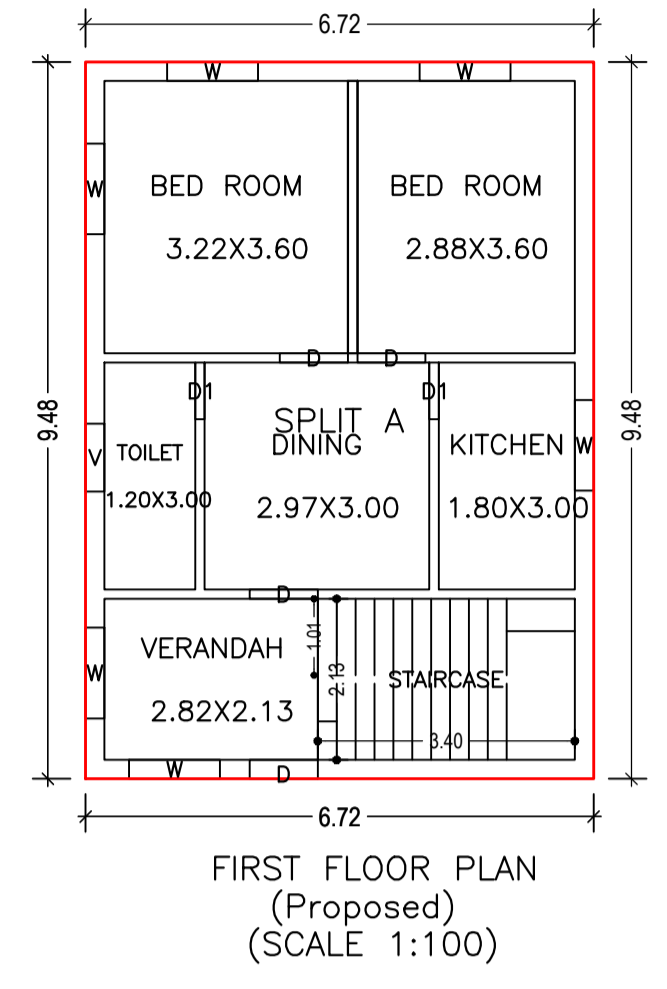
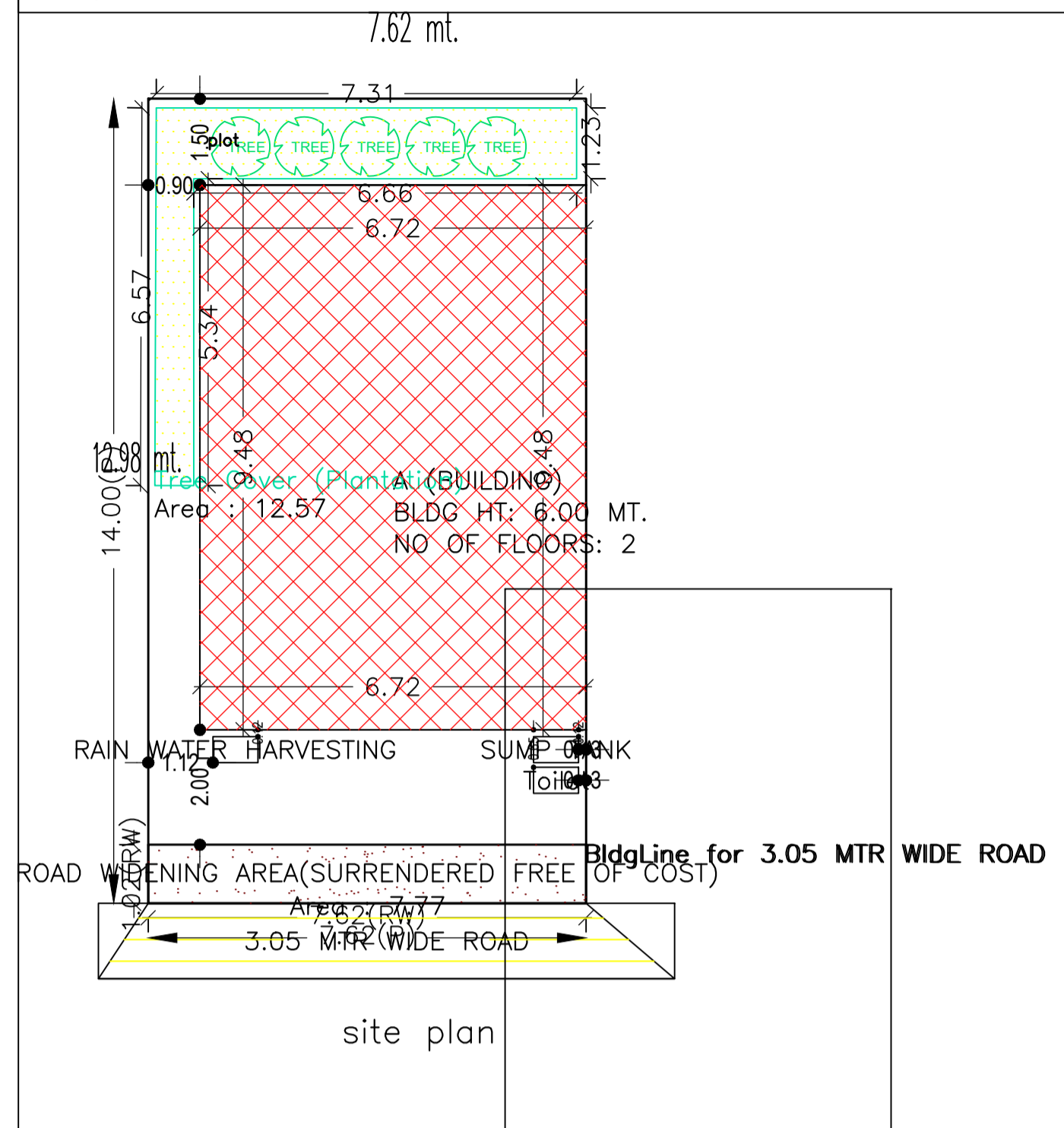

AREA STATEMENT MEDINNAGAR MUNICIPAL CORPORATION	VERSION NO.: 1.0.64 VERSION DATE: 16/10/2020	
PROJECT DETAIL:		
Region: JHARKHAND URBAN LOCAL BODIES	Plot Use: Residential	
District: PALAMU	Plot SubUse: Bungalow/ Dwelling / Non Apartment	
Authority: MEDINNAGAR MUNICIPAL CORPORATION	Plot/Nearby/Religious/Structure: NA	
Inward No: MNNP/BJP/0215/W03/2022	Plot/SubPlot No: 282	
Application Type: General Proposal	North: -	
Project Type: Building Permission	South: -	
Nature of Development: New	East: -	
Location of Development Area: Old Area	West: -	
AREA DETAILS:		
AREA OF PLOT (Minimum)	(A)	106.68
Deduction for NetPlot Area		
Surrender Free of Cost		7.77
Total		7.77
NET AREA OF PLOT(Gross Plot Area - Deduction from Gross Plot area)	(A-Deductions)	98.91
Deduction for Balance Plot Area(from Gross Plot Area)		
Surrender Free of Cost		7.77
Common Plot		12.57
Total		20.34
BALANCE AREA OF PLOT(Net Plot Area - Recreational/Amenity space)	(A-Deductions)	86.34
PLOT AREA FOR COVERAGE(Net Plot Area)	(A-Deductions)	98.91
Plot Area for FAR (Net Plot Area + RoadWidening Area)	(A-Deductions)	106.68
COVERAGE CHECK		
Permissible Coverage area (70.00 %)		69.24
Proposed Coverage Area (64.41 %)		63.71
Total Prop. Coverage Area (64.41 %)		63.71
Balance coverage area (5.59 %)		5.53
FAR CHECK		
Perm. FAR Area (1.20)		128.02
Total Perm. FAR area		128.02
Residential FAR		127.41
Proposed FAR Area		127.41
Total Proposed FAR Area		127.41
Consumed FAR (Factor)		1.19
Balance FAR Area		0.61
BUILT UP AREA CHECK		
Total Proposed BuiltUp Area		127.42
ARCHITECT (Regd)	PANKAJ KUMAR SINGH	
ENGINEER (Regd)		
SUPERVISOR (Regd)		
OWNER (Regd)	Reshmi Devi	
DEVELOPMENT AUTHORITY		LOCAL BODY

COLOR INDEX	
PLOT BOUNDARY	Black
ABUTTING ROAD	Green
PROPOSED CONSTRUCTION	Red
COMMON PLOT	Yellow
ROAD WIDENING AREA	Blue
EXISTING (To be retained)	Orange
EXISTING (To be demolished)	White

Buildingwise Floor FAR Details				
Floor Name	Building Name		Total	
	Proposed Built Up Area (Sq.mt.)	Proposed FAR Area (Sq.mt.)	Total Proposed Built Up Area (Sq.mt.)	Total FAR Area (Sq.mt.)
Ground And Parking Floor	63.71	63.71	63.71	63.71
First Floor	63.71	63.71	63.71	63.71
Terrace Floor	0.00	0.00	0.00	0.00
Total :	127.42	127.42	127.42	127.42

Building USE/SUBUSE Details					
Building Name	Building Use	Building SubUse	Building Structure		
A (BUILDING)	Residential	Bungalow/ Dwelling / Non Apartment	Non-Highrise		
FAR & Tenement Details (Table 4c-1)					
Building	No. of Same Bldg	Total Built Up Area (Sq.mt.)	Proposed FAR Area (Sq.mt.)	Total Consumed Additional FAR Area (Sq.mt.)	Tnmt (No.)
A (BUILDING)	1	127.42	127.42	127.42	01
Grand Total :	1	127.42	127.42	127.42	01

Building :A (BUILDING)					
Floor Name	Total Built Up Area (Sq.mt.)	Proposed FAR Area (Sq.mt.)	Total FAR Area (Sq.mt.)	Total Consumed Additional FAR Area (Sq.mt.)	Tnmt (No.)
Ground And Parking Floor	63.71	63.71	63.71	63.71	01
First Floor	63.71	63.71	63.71	63.71	00
Terrace Floor	0.00	0.00	0.00	0.00	00
Total :	127.42	127.42	127.42	127.42	01
Total Number of Same Buildings :	1				
Total :	127.42	127.42	127.42	127.42	01

UnitBUA Table for Building :A (BUILDING)						
FLOOR	Name	UnitBUA Type	UnitBUA Area	Carpet Area	No. of Rooms	No. of Tenement
FIRST FLOOR PLAN	SPLIT A	FLAT	0.00	0.00	6	0
GROUND AND PARKING FLOOR PLAN	SPLIT A	FLAT	110.04	109.14	6	1
Total:	-	-	110.04	109.14	12	1

SCHEDULE OF DOOR:				
BUILDING NAME	NAME	LENGTH	HEIGHT	NOS
A (BUILDING)	D1	0.75	2.10	04
A (BUILDING)	D	0.90	2.10	08
SCHEDULE OF WINDOW/VENTILATION:				
BUILDING NAME	NAME	LENGTH	HEIGHT	NOS
A (BUILDING)	V	0.90	0.60	02
A (BUILDING)	W	1.20	1.20	12

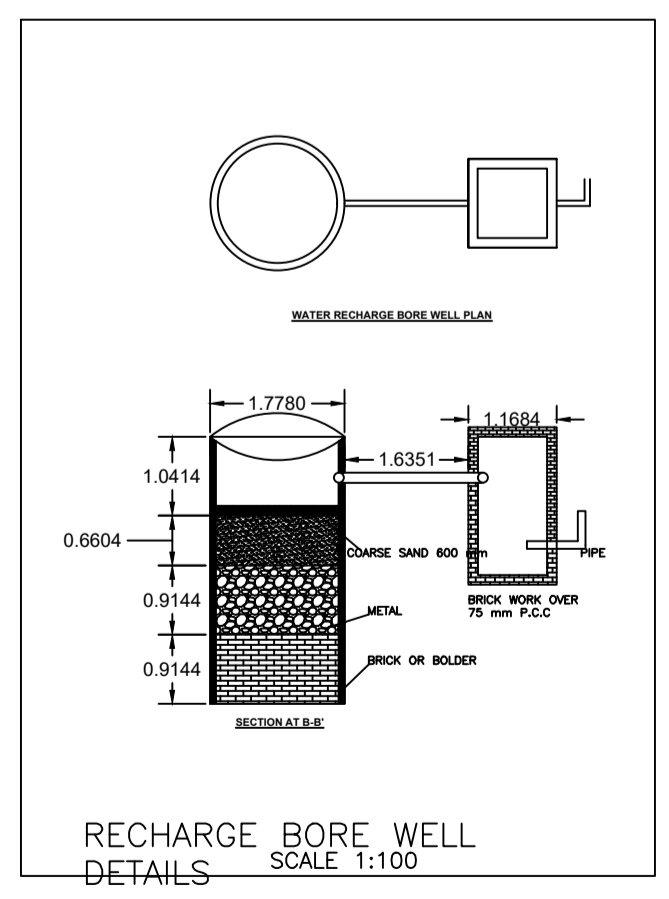
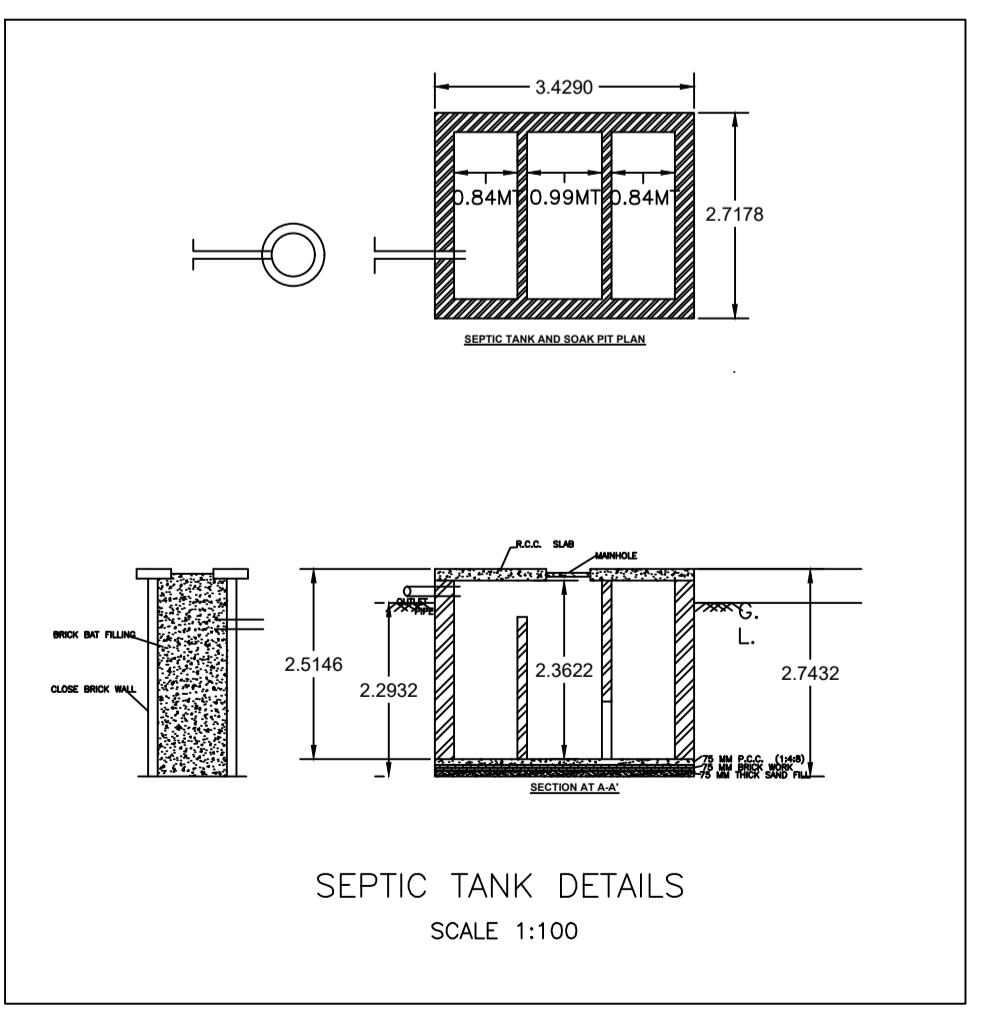

LTP NAME AND SIGNATURE	STRUCTURAL ENG'S NAME AND SIGNATURE	BUILDER NAME AND SIGNATURE	DIGITAL SIGNATURE
PANKAJ KUMAR SINGH MNNP/ENG/0006/2019			