

FAR & Tenement Details (Table 4c-1)

Building	No. of Same Bldg	Total Built Up Area (Sq.mt.)	Proposed FAR Area (Sq.mt.) Resi.	Total FAR Area (Sq.mt.)	Total Consumed Additional FAR Area (Sq.mt.)	Tnmt (No.)
A (BUILDING)	1	129.82	129.82	129.82	129.82	01
Grand Total :	1	129.82	129.82	129.82	129.82	01

Proposal Basic Information

Proposal File No.	MNNP/BP/0222/W03/2022
Owner Name	Basanti Devi
Khata No	1
Plot No	230
Village Name	Sudna
Use	Residential
SubUse	Bungalow/ Dwelling / Non Apartment

AREA STATEMENT

VERSION NO. : 1.0.64	
VERSION DATE: 16/10/2020	
Region: JHARKHAND URBAN LOCAL BODIES	Plot Use: Residential
District: PALAMU	Plot SubUse: Bungalow/ Dwelling / Non Apartment
Authority: MEDININAGAR MUNICIPAL CORPORATION	PlotNearby/ReligiousStructure: NA
Inward No: MNNP/BP/0222/W03/2022	Plot/SubPlot No: 230
Application Type: General Proposal	North: -
Project Type: Building Permission	South: -
Nature of Development: New	East: -
Location of Development Area: Old Area	West: -

AREA DETAILS:

AREA OF PLOT (Minimum)	(A)	SQ.MT.
AREA OF PLOT (Minimum)	(A)	242.31
Deduction for NetPlot Area		
Surrender Free of Cost		1.39
Total		1.39
NET AREA OF PLOT(Gross Plot Area - Deduction from Gross Plot area)	(A-Deductions)	240.92
Deduction for Balance Plot Area(from Gross Plot Area)		
Surrender Free of Cost		1.39
Common Plot		13.84
Total		15.23
BALANCE AREA OF PLOT(Net Plot Area - Recreational/Amenity space)	(A-Deductions)	227.08
PLOT AREA FOR COVERAGE(Net Plot Area)	(A-Deductions)	240.92
Plot Area for FAR (Net Plot Area + Road/Widening Area)	(A-Deductions)	242.31

COVERAGE CHECK

Permissible Coverage area (60.00 %)	144.55
Proposed Coverage Area (26.94 %)	64.91
Total Prop. Coverage Area (26.94 %)	64.91
Balance coverage area (33.06 %)	79.64

FAR CHECK

Perm. FAR Area (1.80)	436.16
Total Perm. FAR area	436.16
Residential FAR	129.83
Proposed FAR Area	129.83
Total Proposed FAR Area	129.83
Consumed FAR (Factor)	0.54
Balance FAR Area	306.33

BUILT UP AREA CHECK

Total Proposed BuiltUp Area	129.82
ARCHITECT (Regd)	PANKAJ KUMAR SINGH
ENGINEER (Regd)	
SUPERVISOR (Regd)	
OWNER (Regd)	Basanti Devi
DEVELOPMENT AUTHORITY	LOCAL BODY

COLOR INDEX

PLOT BOUNDARY	Black
ABUTTING ROAD	Green
PROPOSED CONSTRUCTION	Red
COMMON PLOT	Yellow
ROAD WIDENING AREA	Blue
EXISTING (To be retained)	Orange
EXISTING (To be demolished)	White

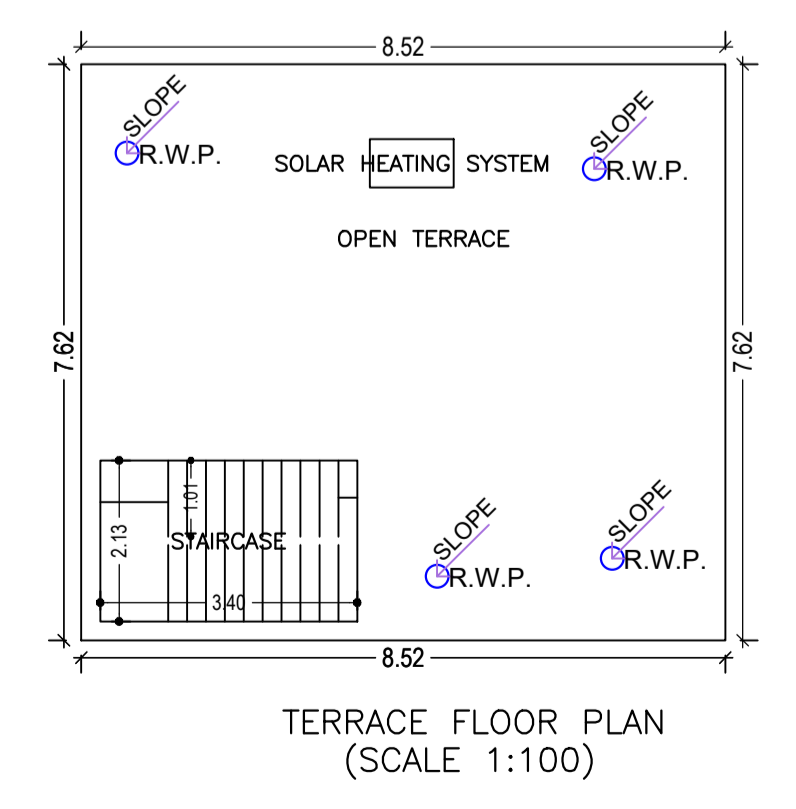
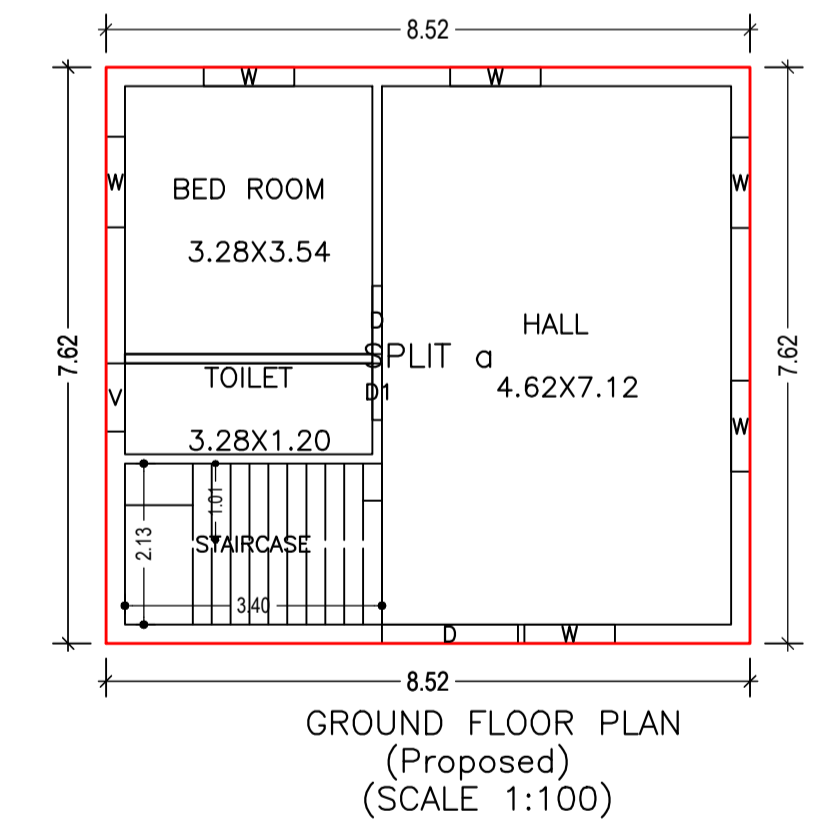
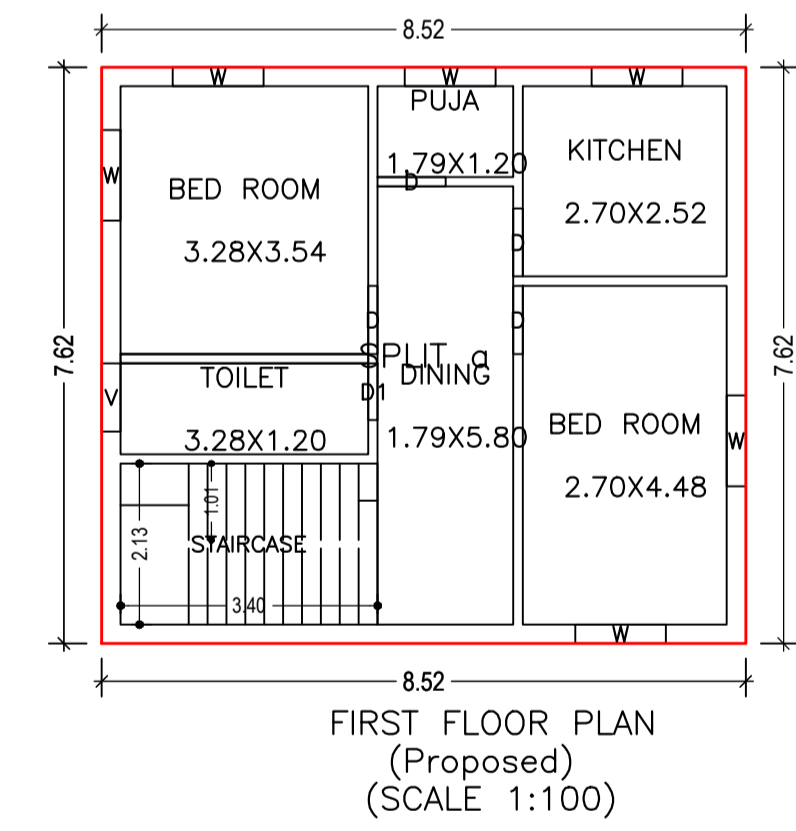

Building :A (BUILDING)

Floor Name	Total Built Up Area (Sq.mt.)	Proposed FAR Area (Sq.mt.) Resi.	Total FAR Area (Sq.mt.)	Total Consumed Additional FAR Area (Sq.mt.)	Tnmt (No.)
Ground Floor	64.91	64.91	64.91	64.91	01
First Floor	64.91	64.91	64.91	64.91	00
Terrace Floor	0.00	0.00	0.00	0.00	00
Total :	129.82	129.82	129.82	129.82	01
Total Number of Same Buildings :	1				
Total :	129.82	129.82	129.82	129.82	01

SCHEDULE OF DOOR:

BUILDING NAME	NAME	LENGTH	HEIGHT	NOS
A (BUILDING)	D1	0.75	2.10	02
A (BUILDING)	D	0.90	2.10	05
A (BUILDING)	D	1.80	2.10	01

SCHEDULE OF WINDOW/VENTILATION:

BUILDING NAME	NAME	LENGTH	HEIGHT	NOS
A (BUILDING)	V	0.90	0.60	02
A (BUILDING)	W	1.20	1.20	12

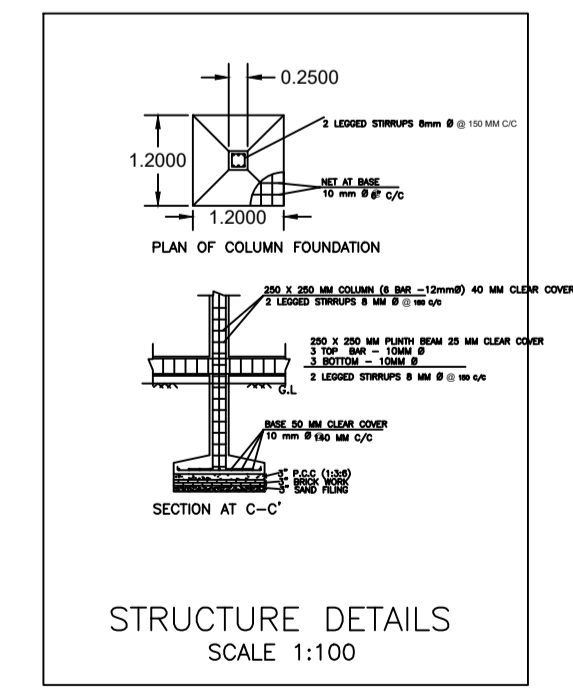
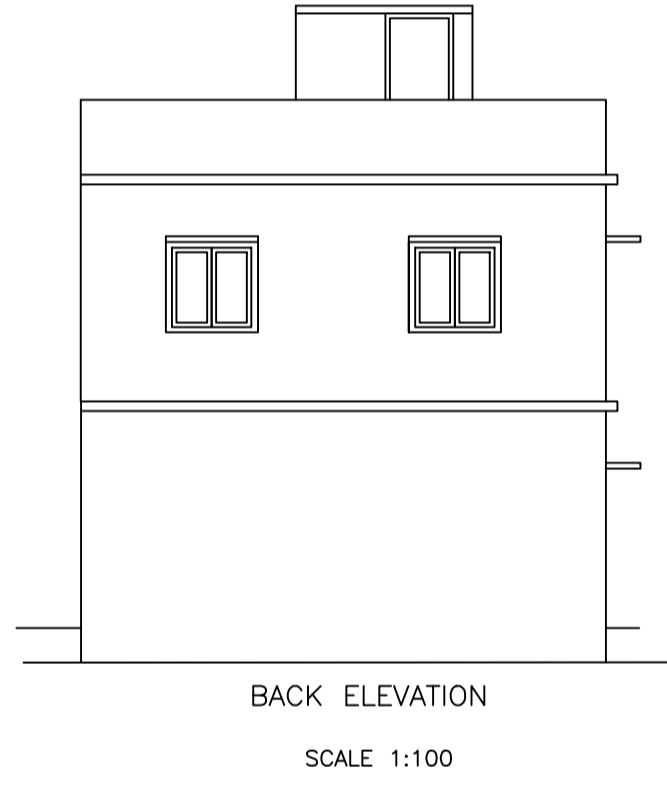
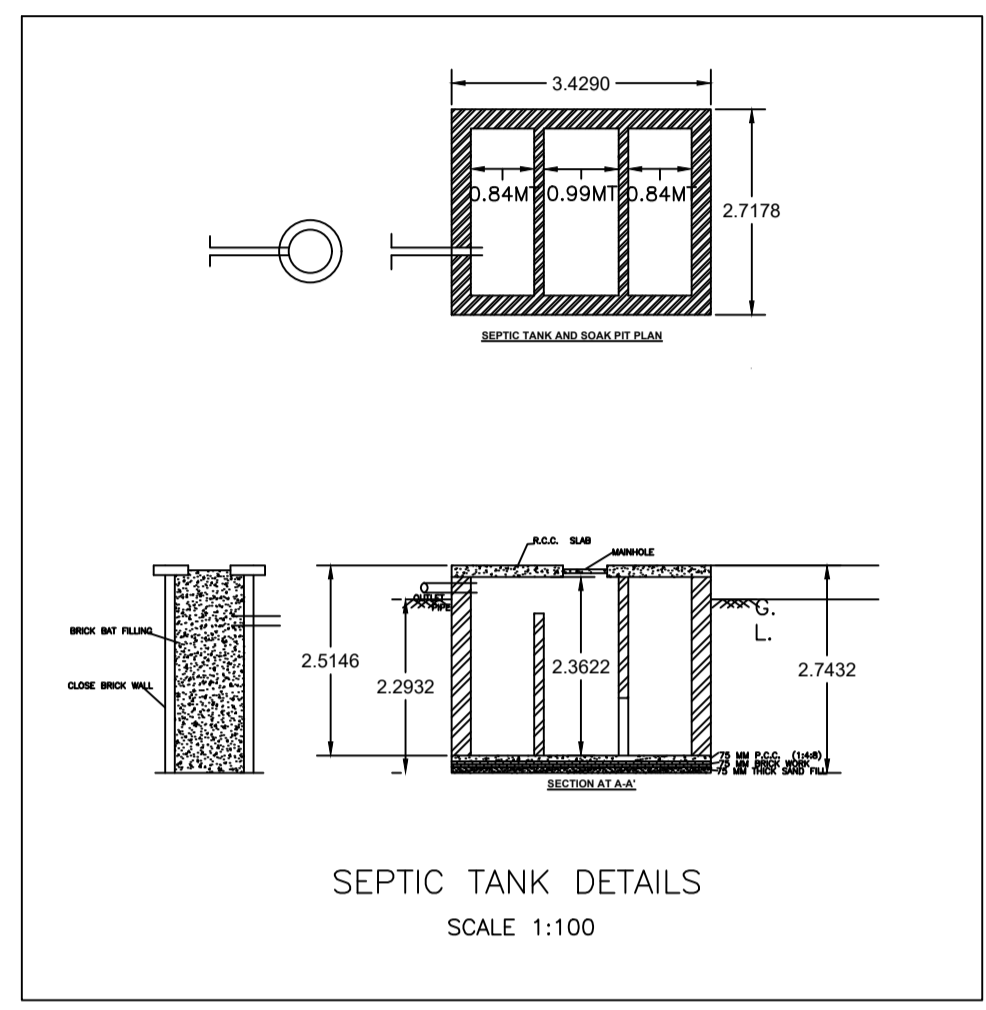
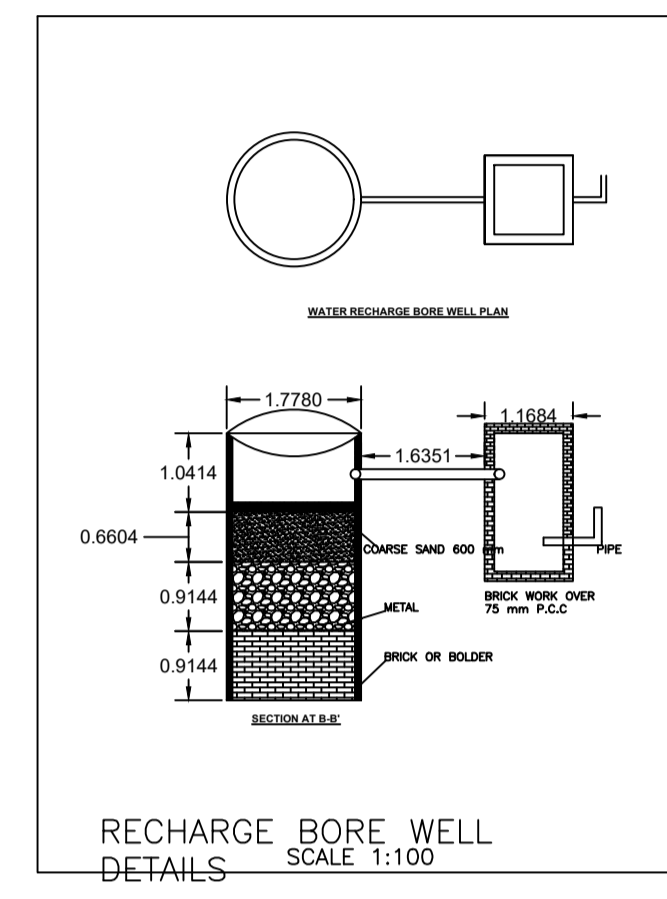

UnitBUA Table for Building :A (BUILDING)

FLOOR	Name	UnitBUA Type	UnitBUA Area	Carpel Area	No. of Rooms	No. of Tenement
FIRST FLOOR PLAN	SPLIT a	FLAT	0.00	0.00	6	0
GROUND FLOOR PLAN	SPLIT a	FLAT	112.46	111.64	3	1
Total:	-	-	112.46	111.64	9	1

Buildingwise Floor FAR Details

Floor Name	Building Name A (BUILDING)		Total	
	Proposed Built Up Area (Sq.mt.)	Proposed FAR Area (Sq.mt.)	Total Proposed Built Up Area (Sq.mt.)	Total FAR Area (Sq.mt.)
Ground Floor	64.91	64.91	64.91	64.91
First Floor	64.91	64.91	64.91	64.91
Terrace Floor	0.00	0.00	0.00	0.00
Total :	129.82	129.82	129.82	129.82

Building USE/SUBUSE Details

Building Name	Building Use	Building SubUse	Building Structure
A (BUILDING)	Residential	Bungalow/ Dwelling / Non Apartment	Non-Highrise

LTP NAME AND SIGNATURE	STRUCTURAL ENG'S NAME AND SIGNATURE	BUILDER NAME AND SIGNATURE	DIGITAL SIGNATURE
PANKAJ KUMAR SINGH MNNP/ENG/0006/2019			