

FAR & Tenement Details (Table 4c-1)

Building	No. of Same Bldg	Total Built Up Area (Sq.mt.)	Proposed FAR Area (Sq.mt.) Resi.	Total FAR Area (Sq.mt.)	Total Consumed Additional FAR Area (Sq.mt.)	Tnmt (No.)
A (BUILDING)	1	181.92	181.92	181.92	181.92	01
Grand Total :	1	181.92	181.92	181.92	181.92	01

Proposal Basic Information

Proposal File No.	MNNP/BP/0082/W04/2022
Owner Name	Naintara Devi
Khata No	65,271
Plot No	71,72
Village Name	Baralota Rodma
Use	Residential
SubUse	Bungalow/ Dwelling / Non Apartment

AREA STATEMENT

AREA DETAILS:	SQ.MT.
AREA OF PLOT (Minimum)	152.25
Deduction for NetPlot Area	
Surrender Free of Cost	10.97
Total	10.97
NET AREA OF PLOT (Gross Plot Area - Deduction from Gross Plot area)	141.27
Deduction for Balance Plot Area (from Gross Plot Area)	
Surrender Free of Cost	10.97
Common Plot	13.12
Total	24.09
BALANCE AREA OF PLOT (Net Plot Area - Recreational/Amenity space)	128.15
PLOT AREA FOR COVERAGE (Net Plot Area)	141.27
Plot Area for FAR (Net Plot Area + Road/Widening Area)	152.25

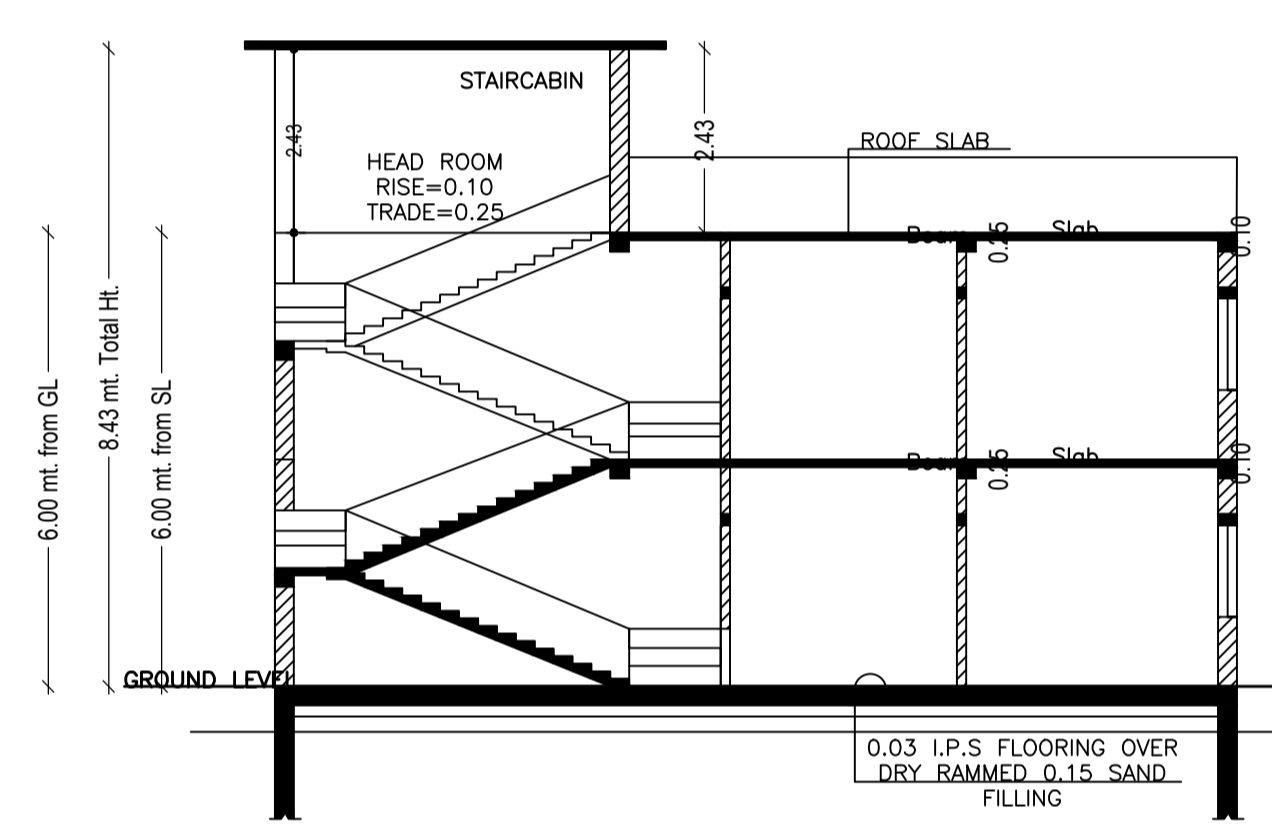
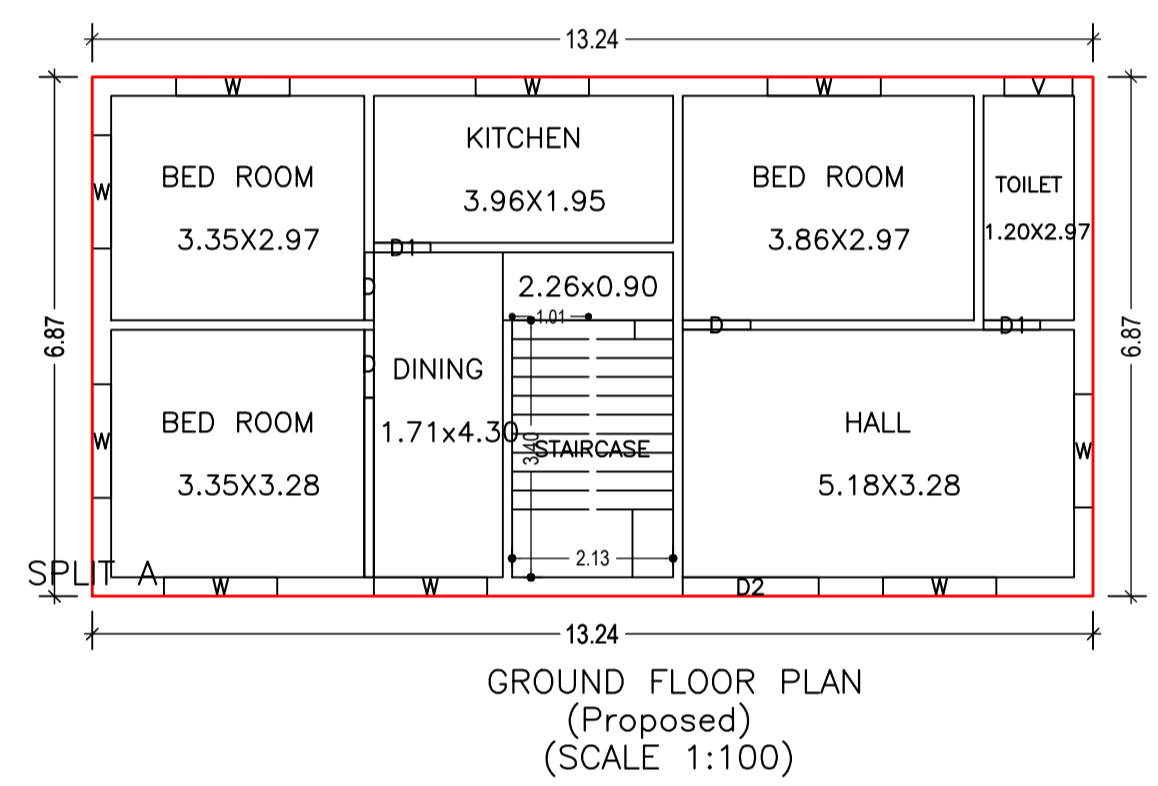

FRONT SIDE ELEVATION

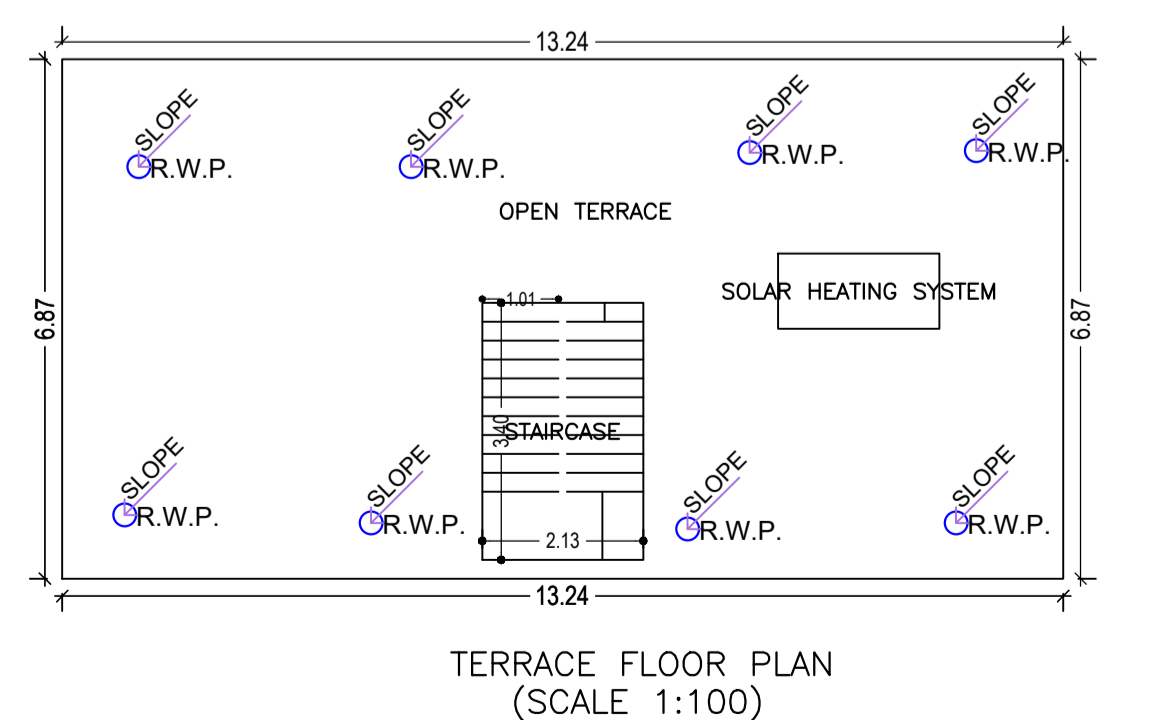
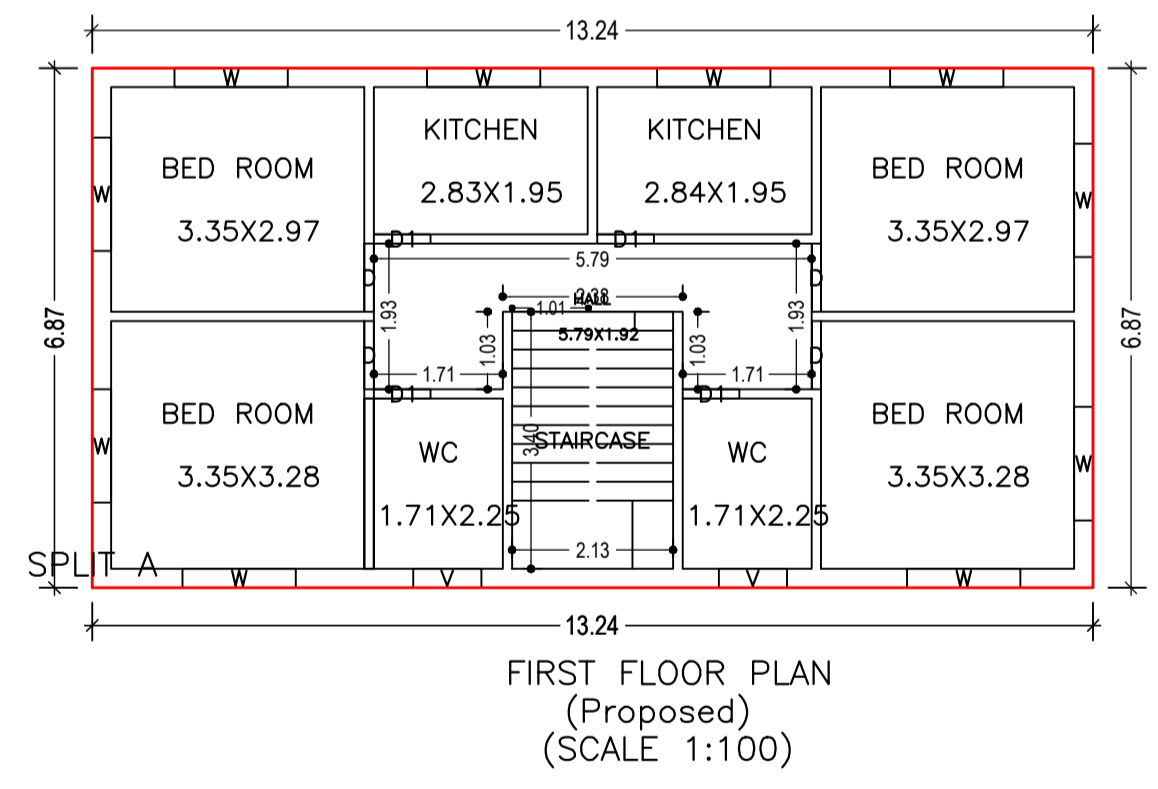
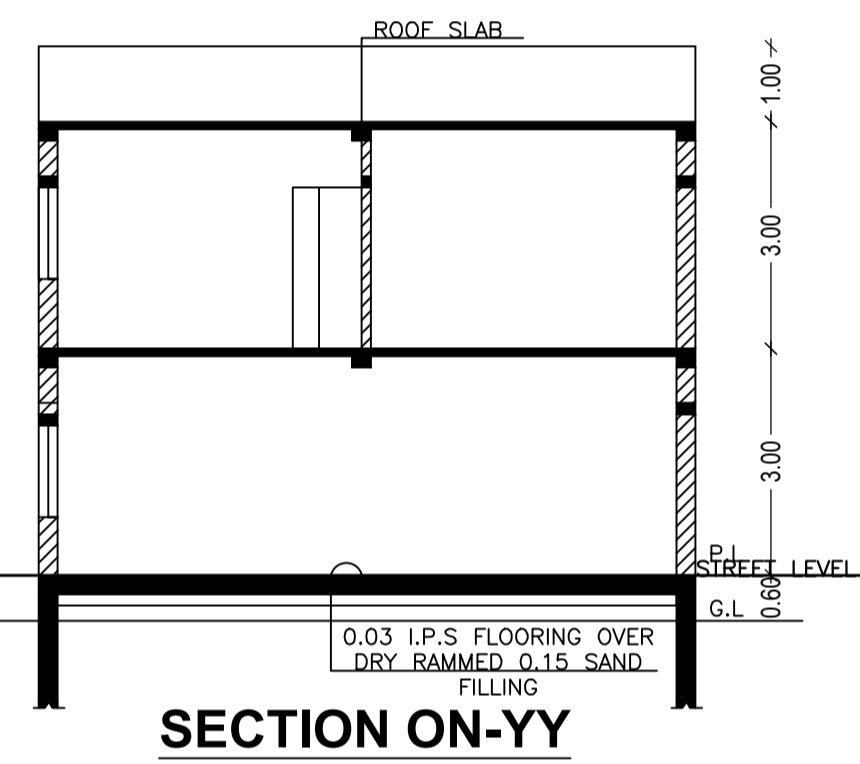

Building :A (BUILDING)

Floor Name	Total Built Up Area (Sq.mt.)	Proposed FAR Area (Sq.mt.) Resi.	Total FAR Area (Sq.mt.)	Total Consumed Additional FAR Area (Sq.mt.)	Tnmt (No.)
Ground Floor	90.96	90.96	90.96	90.96	01
First Floor	90.96	90.96	90.96	90.96	00
Terrace Floor	0.00	0.00	0.00	0.00	00
Total :	181.92	181.92	181.92	181.92	01
Total Number of Same Buildings :	1				
Total :	181.92	181.92	181.92	181.92	01

SCHEDULE OF DOOR:

BUILDING NAME	NAME	LENGTH	HEIGHT	NOS
A (BUILDING)	D1	0.75	2.10	06
A (BUILDING)	D	0.90	2.10	07
A (BUILDING)	D2	1.80	2.10	01

SCHEDULE OF WINDOW/VENTILATION:

BUILDING NAME	NAME	LENGTH	HEIGHT	NOS
A (BUILDING)	V	0.90	0.60	03
A (BUILDING)	W	1.50	1.20	19

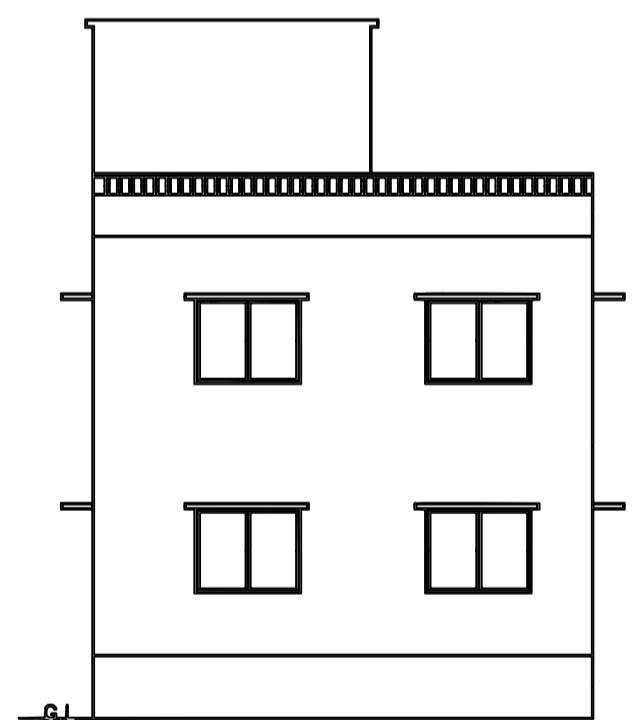
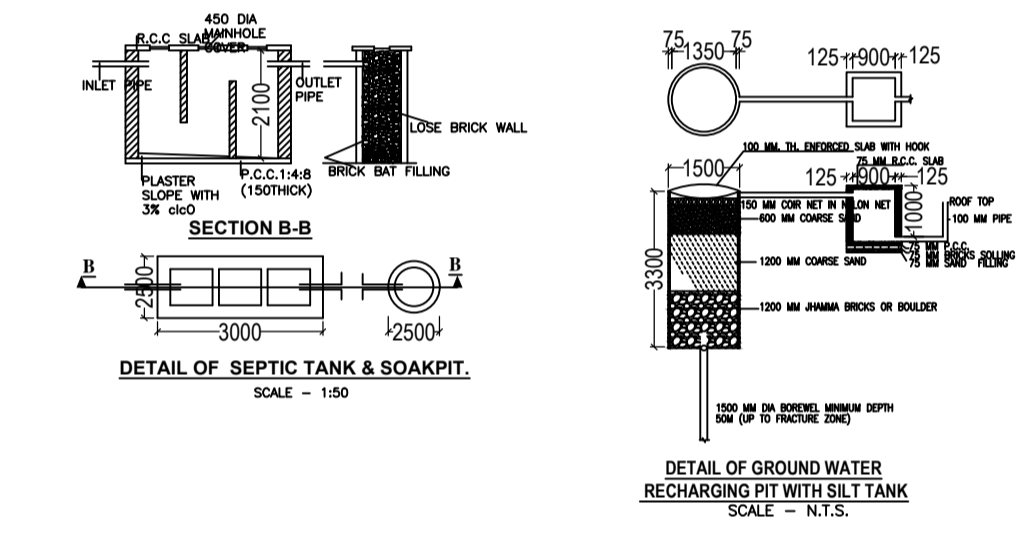

UnitBUA Table for Building :A (BUILDING)

FLOOR	Name	UnitBUA Type	UnitBUA Area	Carpet Area	No. of Rooms	No. of Tenement
GROUND FLOOR PLAN	SPLIT A	FLAT	166.37	165.79	7	1
FIRST FLOOR PLAN	SPLIT A	FLAT	0.00	0.00	9	0
Total:	-	-	166.37	165.79	16	1

COLOR INDEX

PLOT BOUNDARY	[Red Line]
ABUTTING ROAD	[Green Line]
PROPOSED CONSTRUCTION	[Yellow Line]
COMMON PLOT	[Blue Line]
ROAD WIDENING AREA	[Orange Line]
EXISTING (To be retained)	[Grey Line]
EXISTING (To be demolished)	[Black Line]

Buildingwise Floor FAR Details

Floor Name	Building Name A (BUILDING)		Total	
	Proposed Built Up Area (Sq.mt.)	Proposed FAR Area (Sq.mt.)	Total Proposed Built Up Area (Sq.mt.)	Total FAR Area (Sq.mt.)
Ground Floor	90.96	90.96	90.96	90.96
First Floor	90.96	90.96	90.96	90.96
Terrace Floor	0.00	0.00	0.00	0.00
Total :	181.92	181.92	181.92	181.92

Building USE/SUBUSE Details

Building Name	Building Use	Building SubUse	Building Structure
A (BUILDING)	Residential	Bungalow/ Dwelling / Non Apartment	Non-Highrise

LTP NAME AND SIGNATURE	STRUCTURAL ENG'S NAME AND SIGNATURE	BUILDER NAME AND SIGNATURE	DIGITAL SIGNATURE
PANKAJ KUMAR SINGH MNNP/ENG/0006/2019			