

FAR & Tenement Details (Table 4c-1)

Building	No. of Same Bldg	Total Built Up Area (Sq.mt.)	Proposed FAR Area (Sq.mt.) Resi.	Total FAR Area (Sq.mt.)	Total Consumed Additional FAR Area (Sq.mt.)	Tnmt (No.)
A (RESIDENTIAL)	1	103.38	103.38	103.38	103.38	01
Grand Total :	1	103.38	103.38	103.38	103.38	01

Proposal Basic Information

Proposal File No.	MNNP/BP/0132/W09/2022
Owner Name	Sushma Devi
Khata No	40
Plot No	790
Village Name	Sudna
Use	Residential
SubUse	Bungalow/ Dwelling / Non Apartment

AREA STATEMENT
MEDININAGAR MUNICIPAL CORPORATION

VERSION NO: 1.0.62
VERSION DATE: 16/10/2020

PROJECT DETAIL:

Region: JHARKHAND URBAN LOCAL BODIES	Plot Use: Residential
District: PALAMU	Plot SubUse: Bungalow/ Dwelling / Non Apartment
Authority: MEDININAGAR MUNICIPAL CORPORATION	PlotNearbyReligiousStructure: NA
Inward No: MNNP/BP/0132/W09/2022	Plot/SubPlot No: 790
Application Type: General Proposal	North: -
Project Type: Building Permission	South: -
Nature of Development: New	East: -
Location of Development Area: Old Area	West: -

AREA DETAILS:

AREA OF PLOT (Minimum)	(A)	SQ.MT.	185.84
Deduction for NetPlot Area			
Surrender Free of Cost			12.42
Total			12.42
NET AREA OF PLOT(Gross Plot Area - Deduction from Gross Plot area)	(A-Deductions)		173.42
Deduction for Balance Plot Area(from Gross Plot Area)			
Surrender Free of Cost			12.42
Common Plot			19.57
Total			31.99
BALANCE AREA OF PLOT(Net Plot Area - Recreational/Amenity space)	(A-Deductions)		153.85
PLOT AREA FOR COVERAGE(Net Plot Area)	(A-Deductions)		173.42
Plot Area for FAR (Net Plot Area + RoadWidening Area)	(A-Deductions)		185.84

COVERAGE CHECK

Permissible Coverage area (70.00 %)	121.39
Proposed Coverage Area (59.61 %)	103.38
Total Prop. Coverage Area (59.61 %)	103.38
Balance coverage area (10.39 %)	18.01

FAR CHECK

Perm. FAR Area (1.20)	223.01
Total Perm. FAR area	223.01
Residential FAR	103.38
Proposed FAR Area	103.38
Total Proposed FAR Area	103.38
Consumed FAR (Factor)	0.56
Balance FAR Area	119.63

BUILT UP AREA CHECK

Total Proposed BuiltUp Area	103.38
-----------------------------	--------

ARCHITECT (Regd) RANJIT KUMAR
ENGINEER (Regd)
SUPERVISOR (Regd)
OWNER (Regd) Sushma Devi

DEVELOPMENT AUTHORITY LOCAL BODY

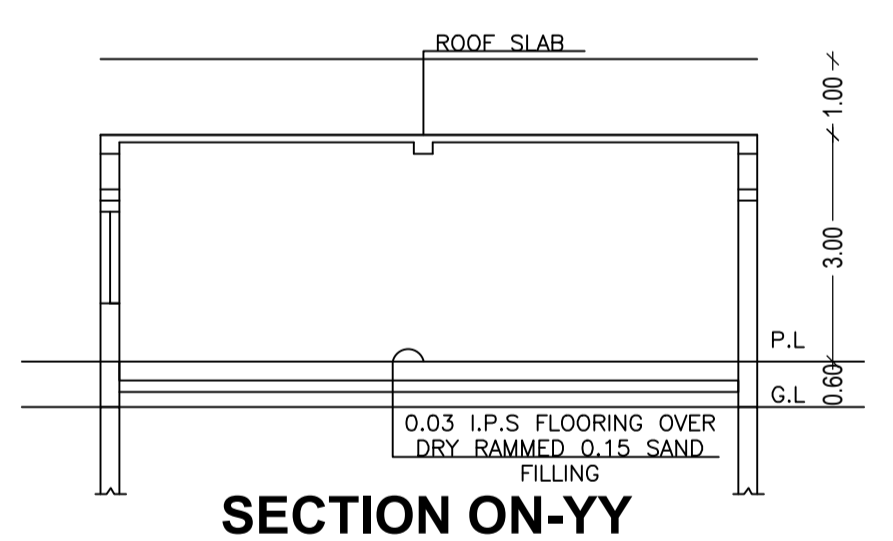
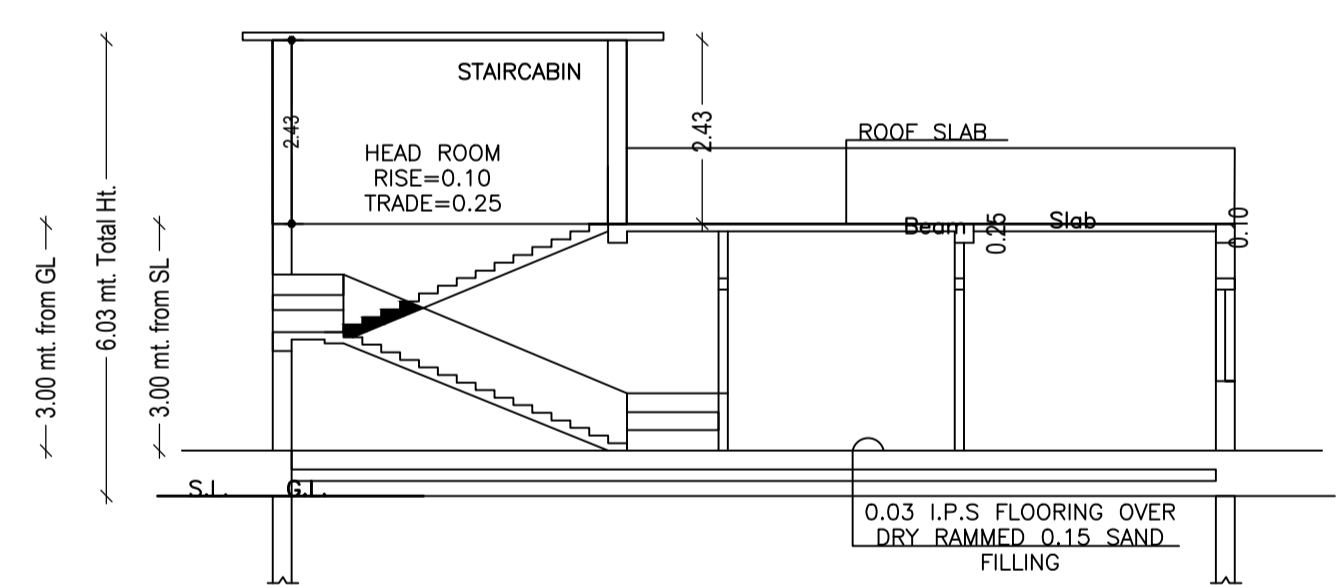
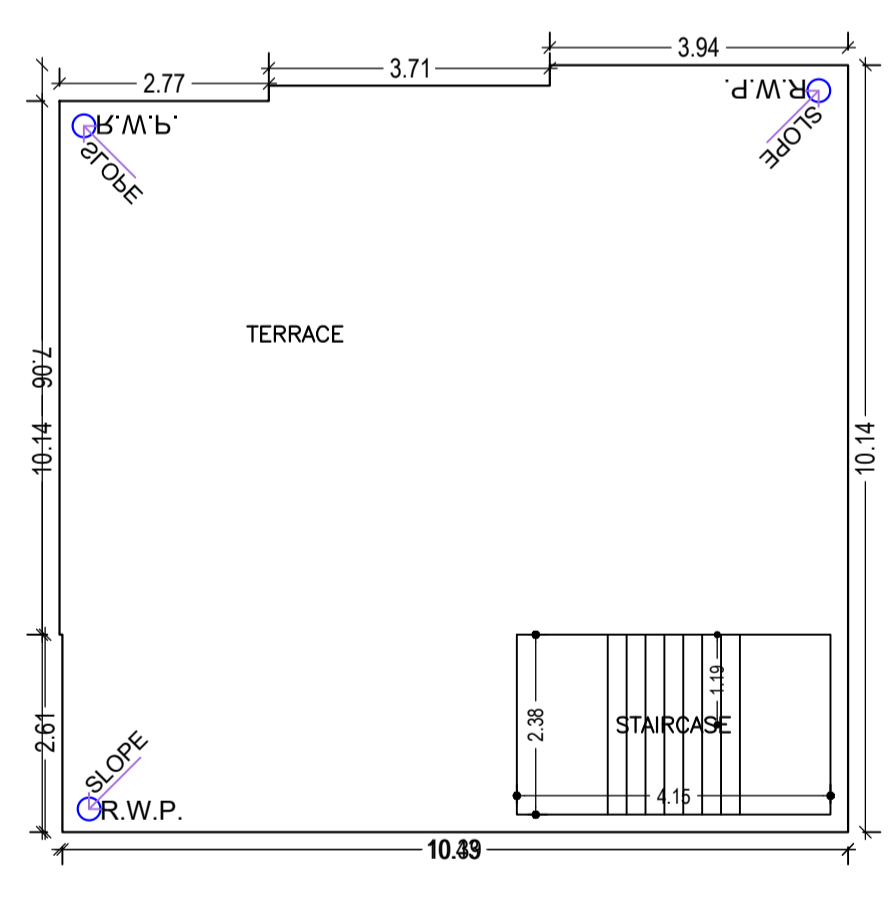
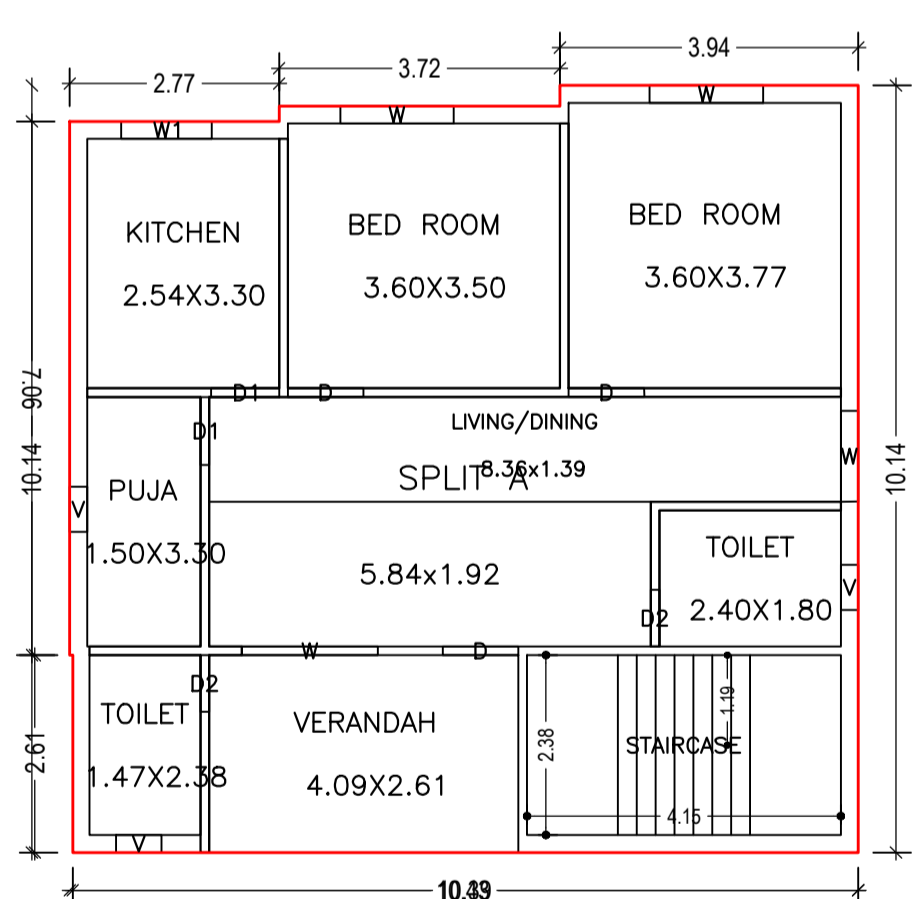
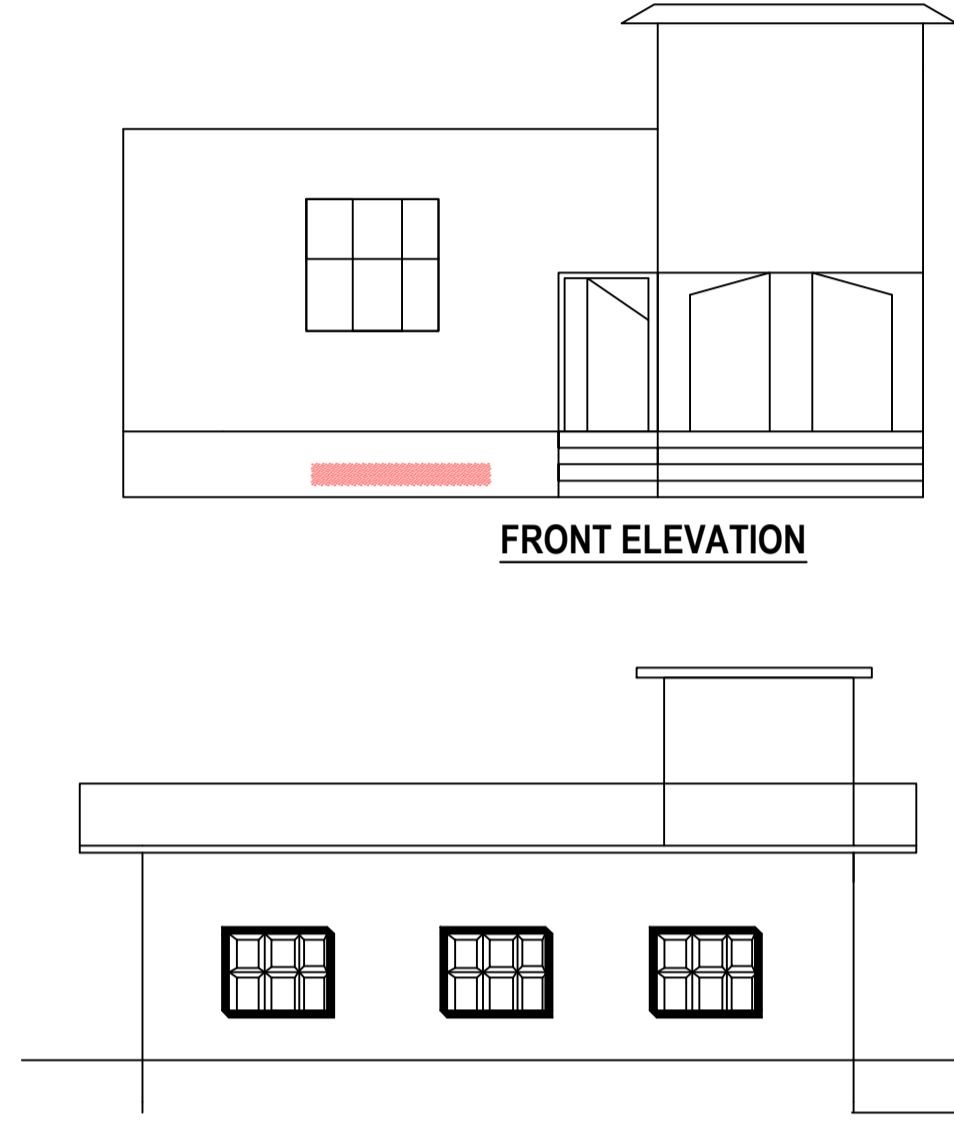

COLOR INDEX

PLOT BOUNDARY	Black
ABUTTING ROAD	Red
PROPOSED CONSTRUCTION	Green
COMMON PLOT	Yellow
ROAD WIDENING AREA	Blue
EXISTING (To be retained)	Orange
EXISTING (To be demolished)	Light Blue

Buildingwise Floor FAR Details

Floor Name	Building Name A (RESIDENTIAL)		Total	
	Proposed Built Up Area (Sq.mt.)	Proposed FAR Area (Sq.mt.)	Total Proposed Built Up Area (Sq.mt.)	Total FAR Area (Sq.mt.)
Ground Floor	103.38	103.38	103.38	103.38
Terrace Floor	0.00	0.00	0.00	0.00
Total :	103.38	103.38	103.38	103.38

Building :A (RESIDENTIAL)

Floor Name	Total Built Up Area (Sq.mt.)	Proposed FAR Area (Sq.mt.) Resi.	Total FAR Area (Sq.mt.)	Total Consumed Additional FAR Area (Sq.mt.)	Tnmt (No.)
Ground Floor	103.38	103.38	103.38	103.38	01
Terrace Floor	0.00	0.00	0.00	0.00	00
Total :	103.38	103.38	103.38	103.38	01
Total Number of Same Buildings	1				
Total :	103.38	103.38	103.38	103.38	01

SCHEDULE OF DOOR:

BUILDING NAME	NAME	LENGTH	HEIGHT	NOS
A (RESIDENTIAL)	D2	0.75	2.10	02
A (RESIDENTIAL)	D1	0.90	2.10	02
A (RESIDENTIAL)	D	1.00	2.10	03

SCHEDULE OF WINDOW/VENTILATION:

BUILDING NAME	NAME	LENGTH	HEIGHT	NOS
A (RESIDENTIAL)	V	0.60	0.90	03
A (RESIDENTIAL)	W1	1.20	1.20	01
A (RESIDENTIAL)	W	1.20	1.20	01
A (RESIDENTIAL)	W	1.50	1.50	02
A (RESIDENTIAL)	W	1.80	1.50	01

UnitBUA Table for Building :A (RESIDENTIAL)

FLOOR	Name	UnitBUA Type	UnitBUA Area	Carpet Area	No. of Rooms	No. of Tenement
GROUND FLOOR PLAN	SPLIT A	FLAT	84.54	81.20	8	1
Total:	-	-	84.54	81.20	8	1

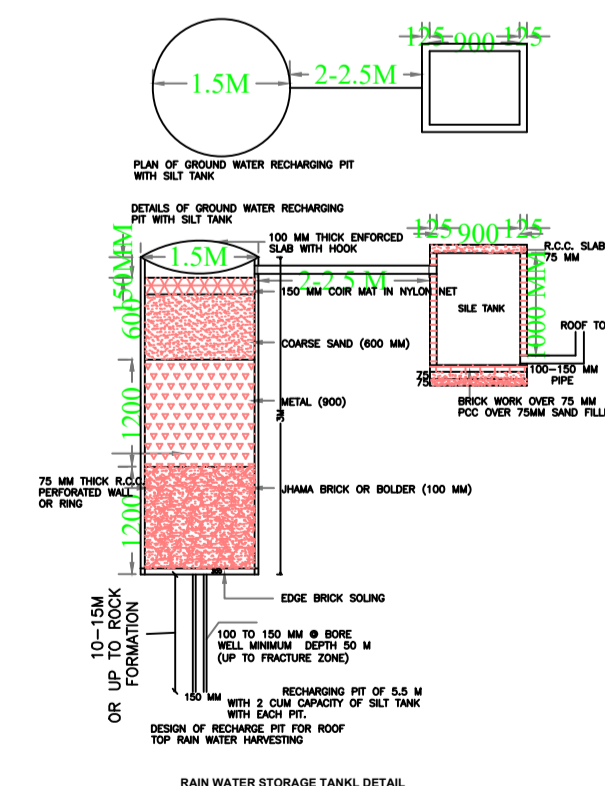

LTP NAME AND SIGNATURE	STRUCTURAL ENG'S NAME AND SIGNATURE	BUILDER NAME AND SIGNATURE	DIGITAL SIGNATURE
RANJIT KUMAR MNNP/ENG/001/2016			