

GROUND FLOOR PLAN (Proposed) (SCALE 1:100)

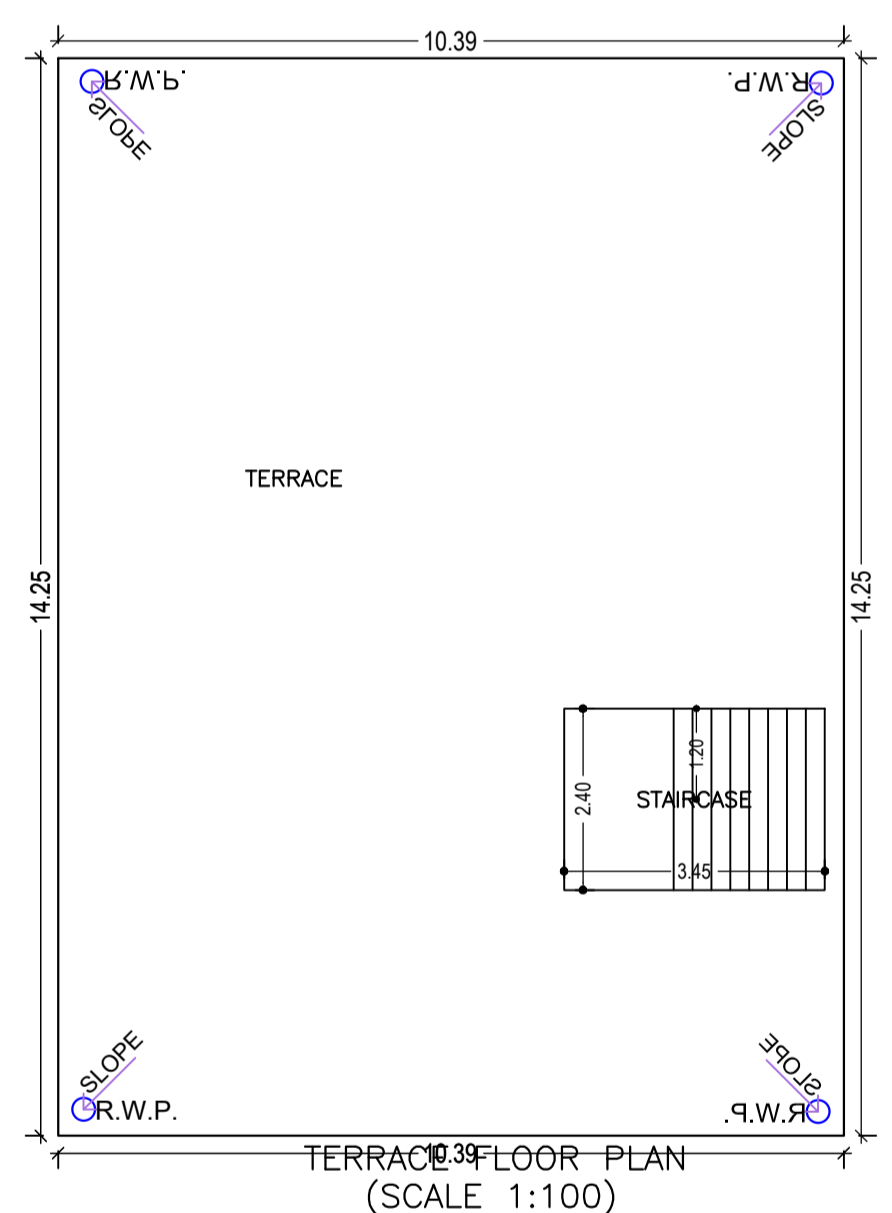

TERRACE FLOOR PLAN (SCALE 1:100)

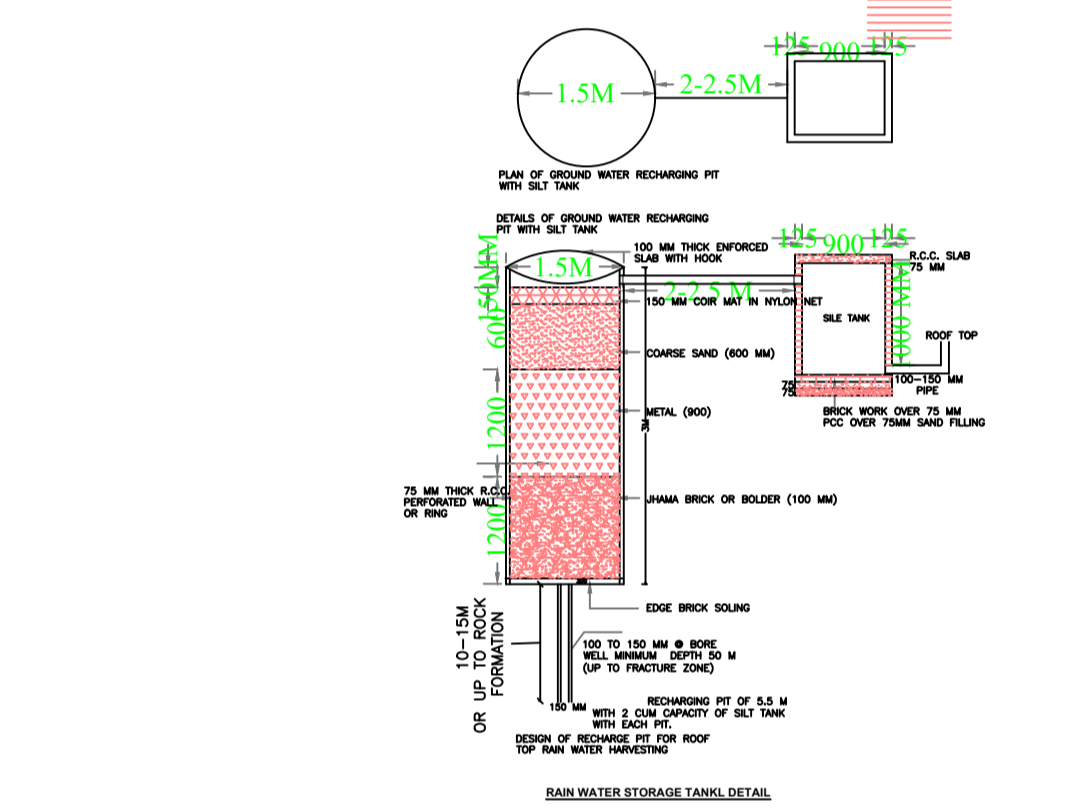
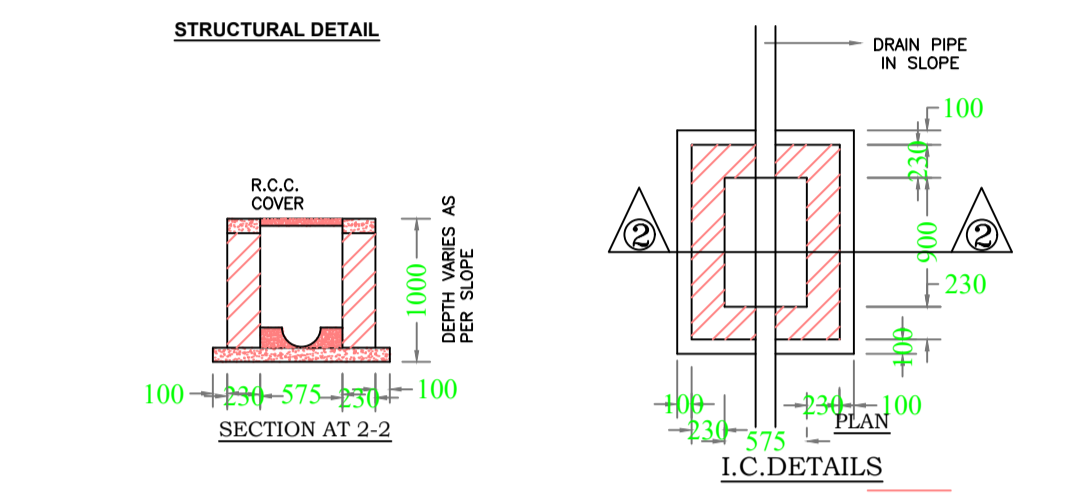
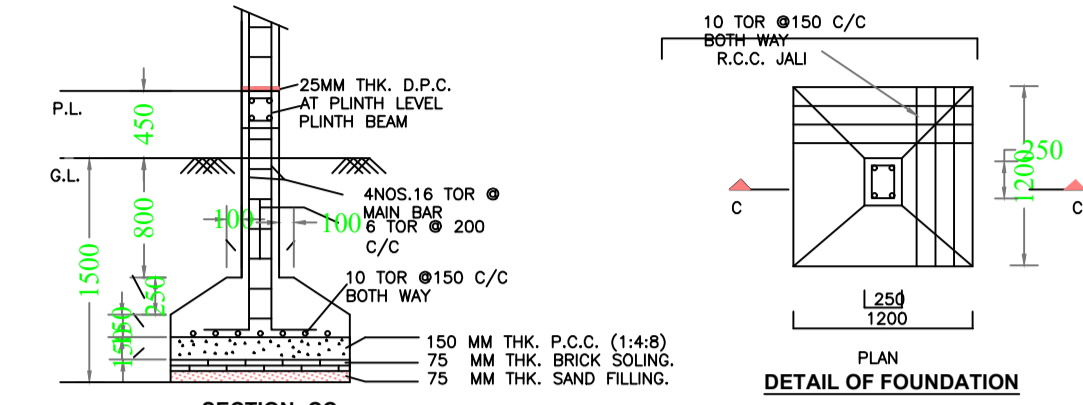

RAIN WATER STORAGE TANK DETAIL

FAR & Tenement Details (Table 4c-1)

Building	No. of Same Bldg	Total Built Up Area (Sq.mt.)	Proposed FAR Area (Sq.mt.) Resi.	Total FAR Area (Sq.mt.)	Total Consumed Additional FAR Area (Sq.mt.)	Tnmt (No.)
A (RESIDENTIAL)	1	139.55	139.55	139.55	139.55	01
Grand Total :	1	139.55	139.55	139.55	139.55	01

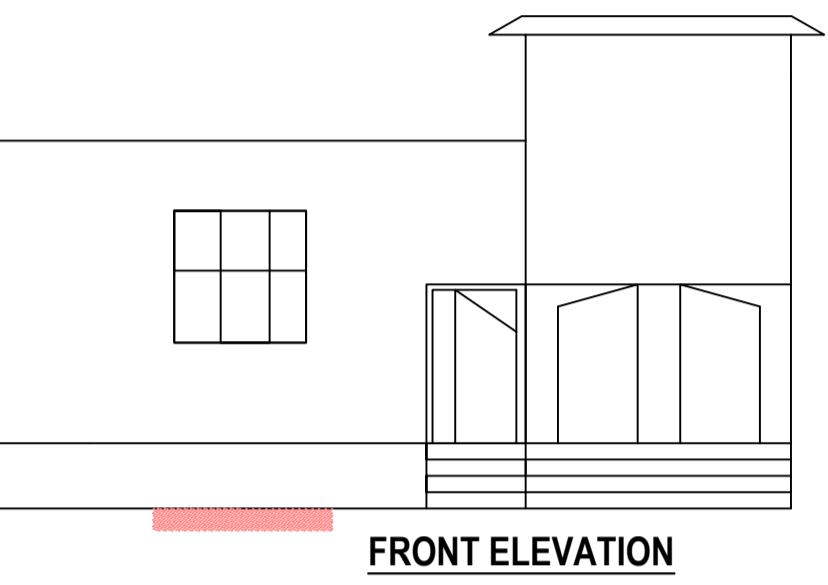

FRONT ELEVATION

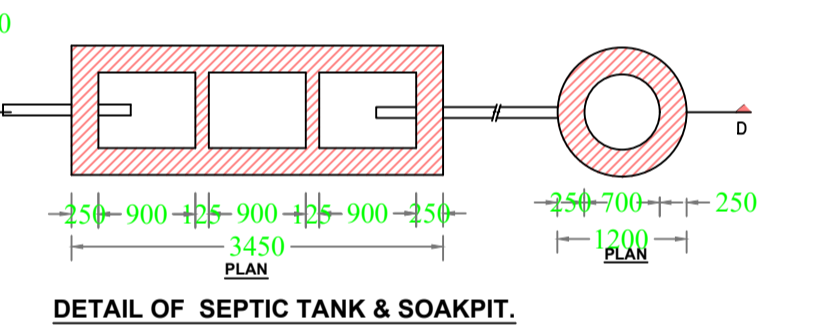
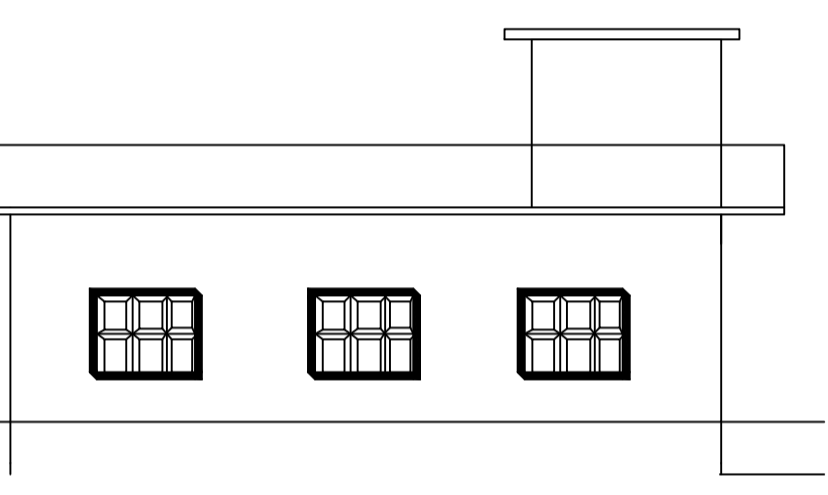

DETAIL OF SEPTIC TANK & SOAKPIT.

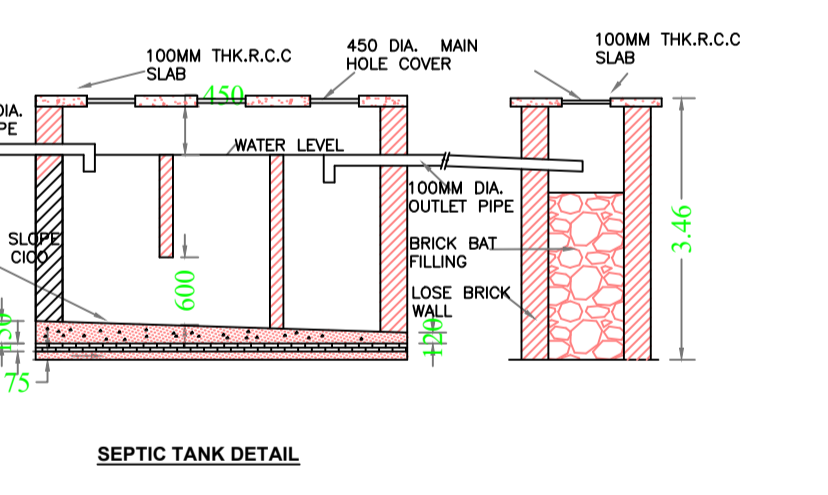

SEPTIC TANK DETAIL

Proposal Basic Information

Proposal File No.	MNNP/BP/0126/W09/2022
Owner Name	Aasha Devi
Khata No	70
Plot No	1340
Village Name	Sudna
Use	Residential
SubUse	Bungalow/ Dwelling / Non Apartment

AREA STATEMENT		VERSION NO. : 1.0.62
MEDININAGAR MUNICIPAL CORPORATION		VERSION DATE: 16/10/2020
PROJECT DETAIL:		
Region: JHARKHAND URBAN LOCAL BODIES	Plot Use: Residential	
District: PALAMU	Plot SubUse: Bungalow/ Dwelling / Non Apartment	
Authority: MEDININAGAR MUNICIPAL CORPORATION	PlotNearby/Religious/Structure: NA	
Inward No: MNNP/BP/0126/W09/2022	Plot/SubPlot No: 1340	
Application Type: General Proposal	North: -	
Project Type: Building Permission	South: -	
Nature of Development: New	East: -	
Location of Development Area: Old Area	West: -	
AREA DETAILS:		
AREA OF PLOT (Minimum)	(A)	SQ.MT. 248.46
Deduction for NetPlot Area		
Surrender Free of Cost		14.87
Total		14.87
NET AREA OF PLOT(Gross Plot Area - Deduction from Gross Plot area)		
(A-Deductions)		233.59
Deduction for Balance Plot Area(from Gross Plot Area)		
Surrender Free of Cost		14.87
Common Plot		33.07
Total		47.94
BALANCE AREA OF PLOT(Net Plot Area - Recreational/Amenity space)		
(A-Deductions)		200.52
PLOT AREA FOR COVERAGE(Net Plot Area)		
(A-Deductions)		233.59
Plot Area for FAR (Net Plot Area + Road/Widening Area)		
(A-Deductions)		248.46
COVERAGE CHECK		
Permissible Coverage area (70.00 %)		163.51
Proposed Coverage Area (59.74 %)		139.55
Total Prop. Coverage Area (59.74 %)		139.55
Balance coverage area (10.26 %)		23.96
FAR CHECK		
Perm. FAR Area (1.50)		372.69
Total Perm. FAR area		372.69
Residential FAR		139.55
Proposed FAR		139.55
Total Proposed FAR Area		139.55
Consumed FAR (Factor)		0.56
Balance FAR Area		233.14
BUILT UP AREA CHECK		
Total Proposed BuiltUp Area		139.55
ARCHITECT (Regd)		
ENGINEER (Regd)		RANJIT KUMAR
SUPERVISOR (Regd)		
OWNER (Regd)		Aasha Devi
DEVELOPMENT AUTHORITY		
		LOCAL BODY

COLOR INDEX

PLOT BOUNDARY	Black
ABUTTING ROAD	Green
PROPOSED CONSTRUCTION	Red
COMMON PLOT	Yellow
ROAD WIDENING AREA	Blue
EXISTING (To be retained)	Orange
EXISTING (To be demolished)	Grey

Building :A (RESIDENTIAL)

Floor Name	Total Built Up Area (Sq.mt.)	Proposed FAR Area (Sq.mt.) Resi.	Total FAR Area (Sq.mt.)	Total Consumed Additional FAR Area (Sq.mt.)	Tnmt (No.)
Ground Floor	139.55	139.55	139.55	139.55	01
Terrace Floor	0.00	0.00	0.00	0.00	00
Total :	139.55	139.55	139.55	139.55	01
Total Number of Same Buildings	1				
Total :	139.55	139.55	139.55	139.55	01

SCHEDULE OF DOOR:

BUILDING NAME	NAME	LENGTH	HEIGHT	NOS
A (RESIDENTIAL)	D2	0.75	2.10	05
A (RESIDENTIAL)	D1	0.90	2.10	01
A (RESIDENTIAL)	D	1.00	2.10	03
A (RESIDENTIAL)	FD	2.44	2.10	01

SCHEDULE OF WINDOW/VENTILATION:

BUILDING NAME	NAME	LENGTH	HEIGHT	NOS
A (RESIDENTIAL)	V	0.60	0.90	04
A (RESIDENTIAL)	W1	1.20	1.20	02
A (RESIDENTIAL)	W	1.20	2.10	01
A (RESIDENTIAL)	W	1.50	1.50	03

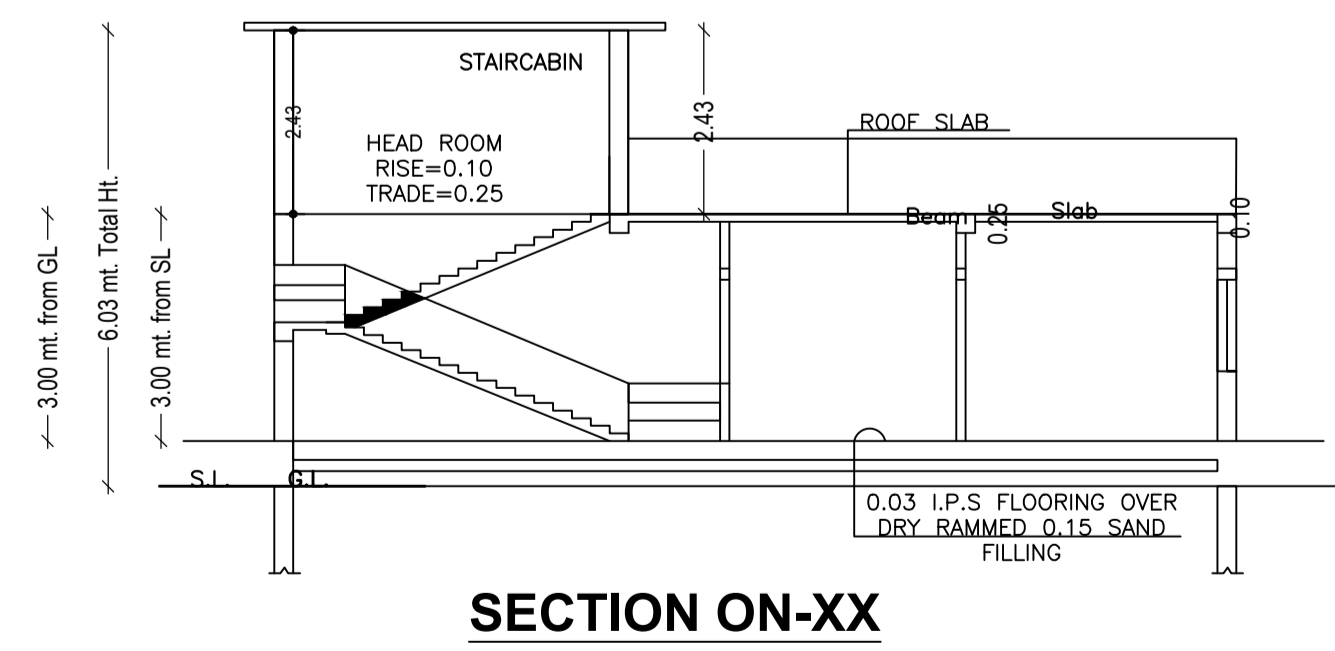

SECTION ON-XX

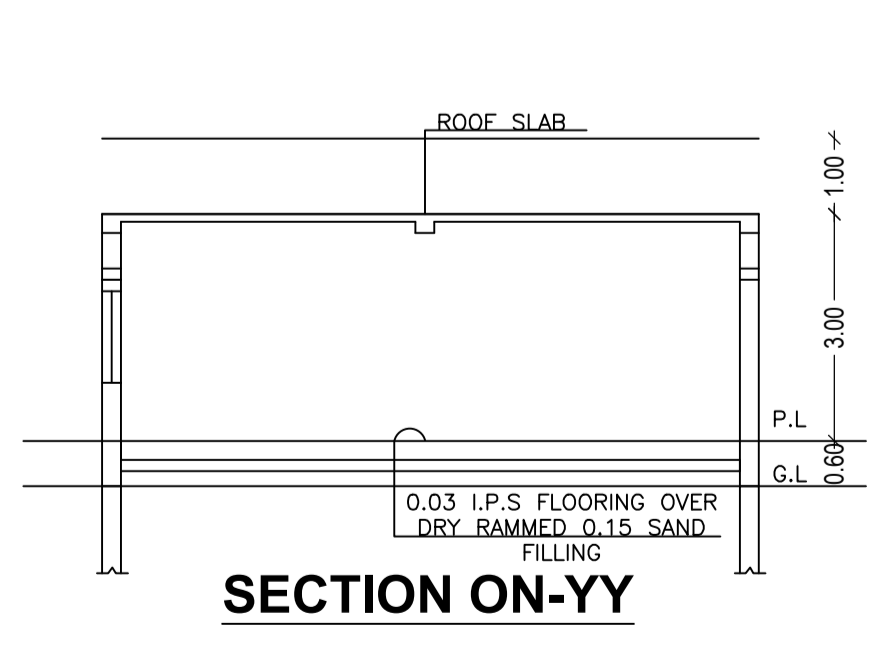

SECTION ON-YY

UnitBUA Table for Building :A (RESIDENTIAL)

FLOOR	Name	UnitBUA Type	UnitBUA Area	Carpet Area	No. of Rooms	No. of Tenement
GROUND FLOOR PLAN	SPLIT A	FLAT	111.59	108.31	11	1
Total:	-	-	111.59	108.31	11	1

LTP NAME AND SIGNATURE	STRUCTURAL ENG'S NAME AND SIGNATURE	BUILDER NAME AND SIGNATURE	DIGITAL SIGNATURE
RANJIT KUMAR MNNP/ENG/0001/2016			