

Proposal Basic Information

Proposal File No.	MNNP/BP/0161/W06/2022
Owner Name	Pravin Kumar Tiwari and archana Tiwari
Khata No	53
Plot No	605
Village Name	Baralota Rodma
Use	Residential
SubUse	Bungalow/ Dwelling / Non Apartment

AREA STATEMENT MEDININAGAR MUNICIPAL CORPORATION

VERSION NO.:	1.0.62	
VERSION DATE:	16/10/2020	
Region:	JHARKHAND URBAN LOCAL BODIES	
District:	PALAMU	
Authority:	MEDININAGAR MUNICIPAL CORPORATION	
Inward No.:	MNNP/BP/0161/W06/2022	
Application Type:	General Proposal	
Project Type:	Building Permission	
Nature of Development:	New	
Location of Development Area:	Old Area	
Plot Use:	Residential	
Plot SubUse:	Bungalow/ Dwelling / Non Apartment	
Plot/Religious/Structure:	NA	
Plot/SubPlot No.:	605	
North:	-	
South:	-	
East:	-	
West:	-	
AREA OF PLOT (Minimum)	(A)	402.29
Deduction for NetPlot Area		
Surrender Free of Cost		16.67
Total		16.67
NET AREA OF PLOT(Gross Plot Area - Deduction from Gross Plot area)	(A-Deductions)	385.62
Deduction for Balance Plot Area(from Gross Plot Area)		
Surrender Free of Cost		16.67
Common Plot		21.89
Total		38.56
BALANCE AREA OF PLOT(Net Plot Area - Recreational/Amenity space)	(A-Deductions)	363.73
PLOT AREA FOR COVERAGE(Net Plot Area)	(A-Deductions)	385.62
Plot Area for FAR (Net Plot Area + Road/Widening Area)	(A-Deductions)	402.29
COVERAGE CHECK		
Permissible Coverage area (60.00 %)		231.37
Proposed Coverage Area (40.43 %)		155.89
Total Prop. Coverage Area (40.43 %)		155.89
Balance coverage area (19.57 %)		75.48
FAR CHECK		
Perm. FAR Area (1.50)		603.43
Total Perm. FAR area		603.43
Residential FAR		155.89
Proposed FAR Area		155.89
Total Proposed FAR Area		155.89
Consumed FAR (Factor)		0.39
Balance FAR Area		447.54
BUILT UP AREA CHECK		
Total Proposed BuiltUp Area		155.89
ARCHITECT (Regd.)	PANKAJ KUMAR SINGH	
ENGINEER (Regd.)	PANKAJ KUMAR SINGH	
SUPERVISOR (Regd.)	PANKAJ KUMAR SINGH	
OWNER (Regd.)	Pravin Kumar Tiwari and archana Tiwari	
DEVELOPMENT AUTHORITY	LOCAL BODY	

COLOR INDEX

PLOT BOUNDARY	Black
ABUTTING ROAD	Red
PROPOSED CONSTRUCTION	Green
COMMON PLOT	Yellow
ROAD WIDENING AREA	Blue
EXISTING (To be retained)	Orange
EXISTING (To be demolished)	Light Blue

Buildingwise Floor FAR Details

Floor Name	Building Name		Total	
	Proposed Built Up Area (Sq.mt.)	Proposed FAR Area (Sq.mt.)	Total Proposed Built Up Area (Sq.mt.)	Total FAR Area (Sq.mt.)
Ground Floor	155.89	155.89	155.89	155.89
Terrace Floor	0.00	0.00	0.00	0.00
Total :	155.89	155.89	155.89	155.89

Building USE/SUBUSE Details

Building Name	Building Use	Building SubUse	Building Structure
A (BUILDING)	Residential	Bungalow/ Dwelling / Non Apartment	Non-Highrise

FAR & Tenement Details (Table 4c-1)

Building	No. of Same Bldg	Total Built Up Area (Sq.mt.)	Proposed FAR Area (Sq.mt.)	Total FAR Area (Sq.mt.)	Total Consumed Additional FAR Area (Sq.mt.)	Trmt (No.)
A (BUILDING)	1	155.89	155.89	155.89	155.89	01
Grand Total :	1	155.89	155.89	155.89	155.89	01

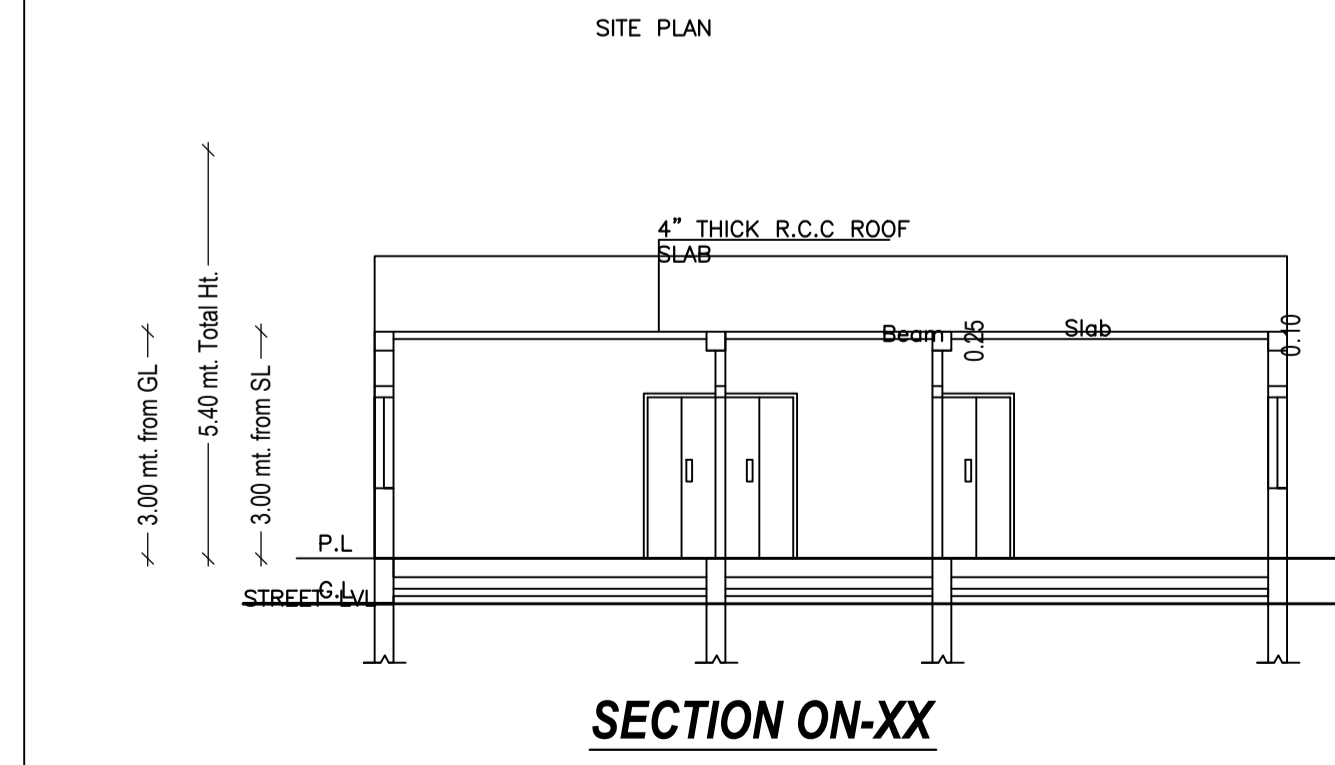

Building :A (BUILDING)

Floor Name	Total Built Up Area (Sq.mt.)	Proposed FAR Area (Sq.mt.) Resi.	Total FAR Area (Sq.mt.)	Total Consumed Additional FAR Area (Sq.mt.)	Trmt (No.)
Ground Floor	155.89	155.89	155.89	155.89	01
Terrace Floor	0.00	0.00	0.00	0.00	00
Total :	155.89	155.89	155.89	155.89	01
Total Number of Same Buildings :	1				
Total :	155.89	155.89	155.89	155.89	01

SCHEDULE OF DOOR:

BUILDING NAME	NAME	LENGTH	HEIGHT	NOS
A (BUILDING)	D1	0.75	2.10	02
A (BUILDING)	D	0.90	2.10	08

SCHEDULE OF WINDOW/VENTILATION:

BUILDING NAME	NAME	LENGTH	HEIGHT	NOS
A (BUILDING)	V	0.90	0.60	02
A (BUILDING)	W	1.20	1.20	12

UnitBUA Table for Building :A (BUILDING)

FLOOR	Name	UnitBUA Type	UnitBUA Area	Carpet Area	No. of Rooms	No. of Tenement
GROUND FLOOR PLAN	SPLIT A	FLAT	147.20	146.71	11	1
Total:	-	-	147.20	146.71	11	1

LTP NAME AND SIGNATURE	STRUCTURAL ENG'S NAME AND SIGNATURE	BUILDER NAME AND SIGNATURE	DIGITAL SIGNATURE
PANKAJ KUMAR SINGH MNNP/ENG/0006/2019			