

SITE PLAN

FAR & Tenement Details (Table 4c-1)

Building	No. of Same Bldg	Total Built Up Area (Sq.mt.)	Deductions (Area in Sq.mt.)		Proposed FAR Area (Sq.mt.)		Total FAR Area (Sq.mt.)	Total Consumed Additional FAR Area (Sq.mt.)	Trmnt (No.)
			Parking	Resi.	Commercial	Resi.			
A (BUILDING)	1	348.06	100.72	116.02	116.02	232.04	232.04	02	
Grand Total :	1	348.06	100.72	116.02	116.02	232.04	232.04	02	

Proposal Basic Information

Proposal File No.	MNNP/BP/0186/W02/2022
Owner Name	Prabhawati Devi
Khata No	39,44
Plot No	135,137
Village Name	Sudna
Use	Mixed
SubUse	Resi+Comm

Required Parking (Table 7a)

Building Name	Type	SubUse	Area (Sq.mt.)	Units		Car		Visitors Car		TwoWheeler			
				Reqd.	Prop.	Reqd./Unit	Reqd.	Prop.	Reqd./Unit	Reqd.	Prop.	Reqd./Unit	Reqd.
A (BUILDING)	Commercial	Commercial Bldg	>0	100	108.57	1	1	-	-	-	-	-	
		Bungalow/Dwelling / Non Apartment	>0	100	108.57	-	-	-	-	-	1	3	
	Residential	>0	1	1.00	1	1	-	-	-	-	-		
Total :			-	-	-	2	5	-	1	1	-	3	6

Parking Check (Table 7b)

Vehicle Type	Reqd.		Prop.	
	No.	Area	No.	Area
Car	-	-	5	62.50
Total Car	2	25.00	5	62.50
Visitor's Car Parking	-	-	1	12.50
Total Visitor Parking	1	12.50	1	12.50
TwoWheeler	-	-	6	12.00
Total TwoWheeler	3	6.00	6	12.00
Other Parking	-	-	-	76.22
Total	-	43.50	-	175.22

AREA STATEMENT MEDININAGAR MUNICIPAL CORPORATION	VERSION NO. : 1.0.62 VERSION DATE: 16/10/2020
PROJECT DETAIL:	
Region: JHARKHAND URBAN LOCAL BODIES	Plot Use: Mixed
District: PALAMU	Plot SubUse: Resi+Comm
Authority: MEDININAGAR MUNICIPAL CORPORATION	PlotNearbyReligiousStructure: NA
Inward No: MNNP/BP/0186/W02/2022	Plot/SubPlot No: 135,137
Application Type: General Proposal	North: -
Project Type: Building Permission	South: -
Nature of Development: New	East: -
Location of Development Area: Old Area	West: -
AREA DETAILS:	SQ.MT.
AREA OF PLOT (Minimum)	(A) 322.20
NET AREA OF PLOT(Gross Plot Area - Deduction from Gross Plot area)	(A-Deductions) 322.20
Deduction for Balance Plot Area(from Gross Plot Area)	
Common Plot	39.11
Total	39.11
BALANCE AREA OF PLOT(Net Plot Area - Recreational/Amenity space)	(A-Deductions) 283.09
PLOT AREA FOR COVERAGE(Net Plot Area)	(A-Deductions) 322.20
Plot Area for FAR (Net Plot Area + Road Widening Area)	(A-Deductions) 322.20
COVERAGE CHECK	
Permissible Coverage area (60.00 %)	193.32
Proposed Coverage Area (36.01 %)	116.02
Total Prop. Coverage Area (36.01 %)	116.02
Balance coverage area (23.99 %)	77.30
FAR CHECK	
Perm. FAR Area (2.50)	805.50
Total Perm. FAR area	805.50
Commercial FAR	116.02
Proposed FAR Area	232.04
Total Proposed FAR Area	232.04
Consumed FAR (Factor)	0.72
Balance FAR Area	573.46
BUILT UP AREA CHECK	
Total Proposed BuiltUp Area	348.06
ARCHITECT (Regd)	PANKAJ KUMAR SINGH
ENGINEER (Regd)	
SUPERVISOR (Regd)	
OWNER (Regd)	Prabhawati Devi
DEVELOPMENT AUTHORITY	LOCAL BODY

COLOR INDEX	
PLOT BOUNDARY	
ABUTTING ROAD	
PROPOSED CONSTRUCTION	
COMMON PLOT	
ROAD WIDENING AREA	
EXISTING (To be retained)	
EXISTING (To be demolished)	

Buildingwise Floor FAR Details

Floor Name	Building Name A (BUILDING)		Total	
	Proposed Built Up Area (Sq.mt.)	Proposed FAR Area (Sq.mt.)	Total Proposed Built Up Area (Sq.mt.)	Total FAR Area (Sq.mt.)
Basement Floor	116.02	0.00	116.02	0.00
Ground Floor	116.02	116.02	116.02	116.02
First Floor	116.02	116.02	116.02	116.02
Terrace Floor	0.00	0.00	0.00	0.00
Total :	348.06	232.04	348.06	232.04

Building USE/SUBUSE Details

Building Name	Building Use	Building SubUse	Building Structure
A (BUILDING)	Commercial	Commercial Bldg	Non-Highrise

LTP NAME AND SIGNATURE	STRUCTURAL ENG'S NAME AND SIGNATURE	BUILDER NAME AND SIGNATURE	DIGITAL SIGNATURE
PANKAJ KUMAR SINGH MNNP/ENG/0006/2019			

Proposal Basic Information	
Proposal File No.	MNNP/BI/0186/W02/2022
Owner Name	Prabhawati Devi
Khata No	39,44
Plot No	135,137
Village Name	Sudna
Use	Mixed
SubUse	Resi+Comm

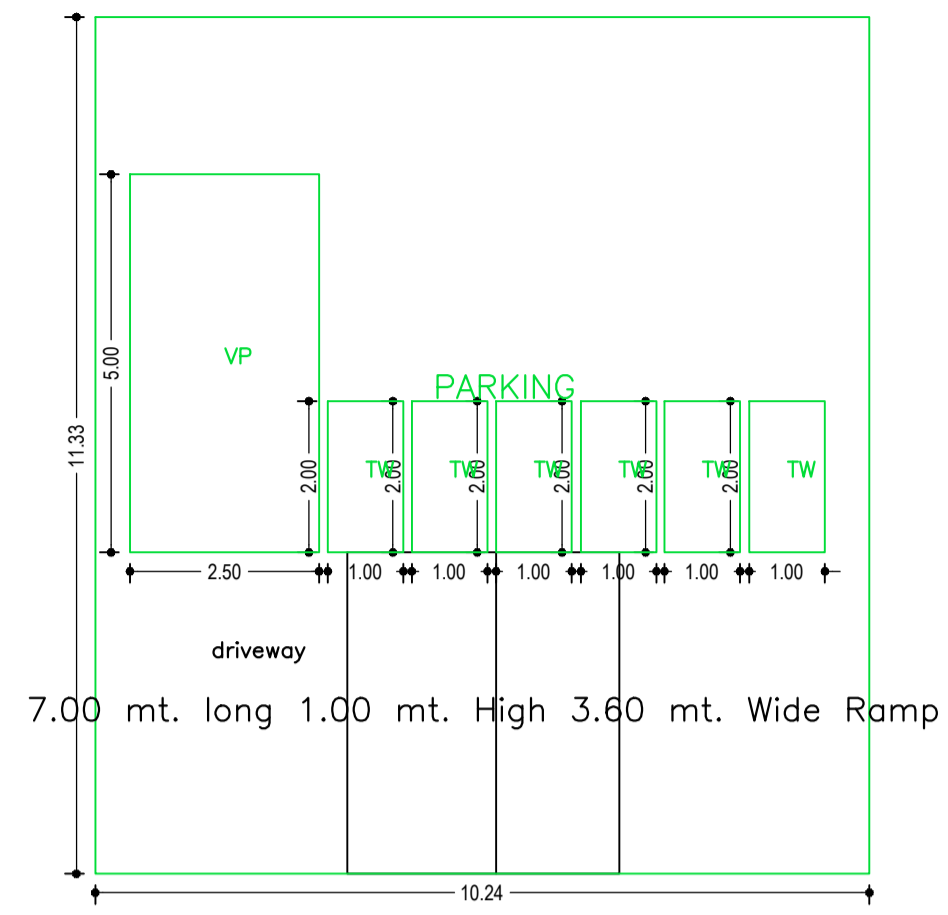

BASEMENT FLOOR PLAN (SCALE 1:100)

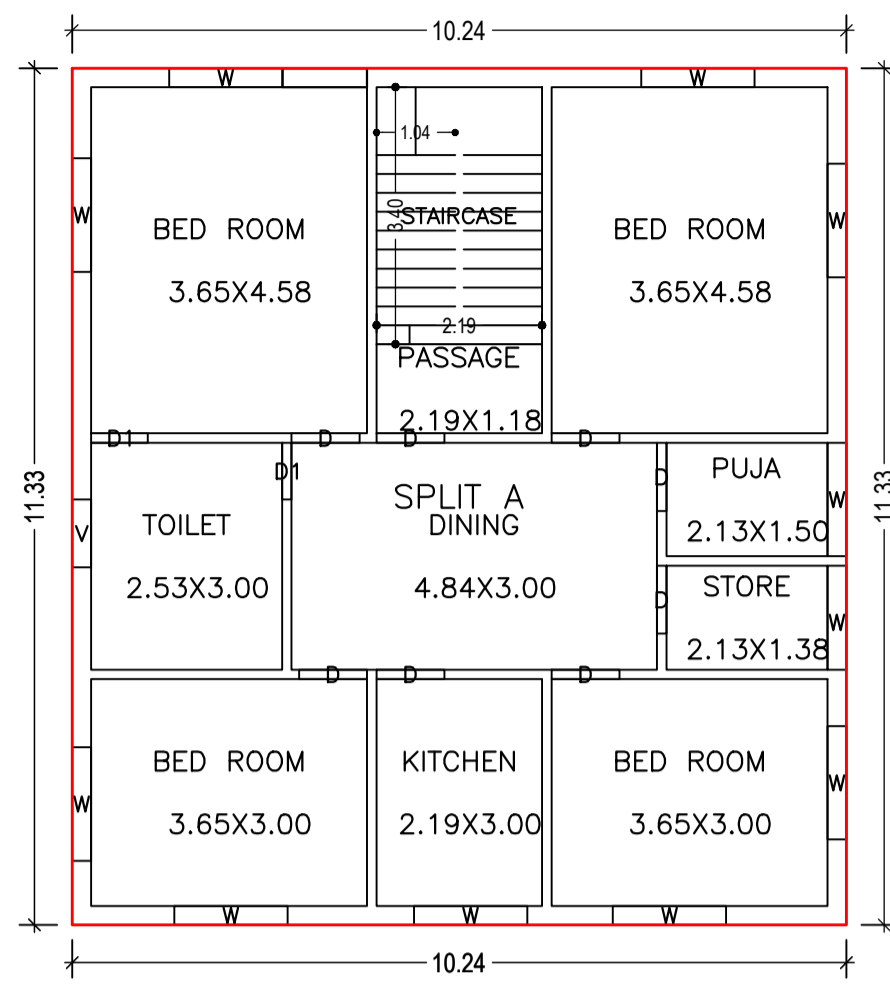

FIRST FLOOR PLAN (Proposed) (SCALE 1:100)

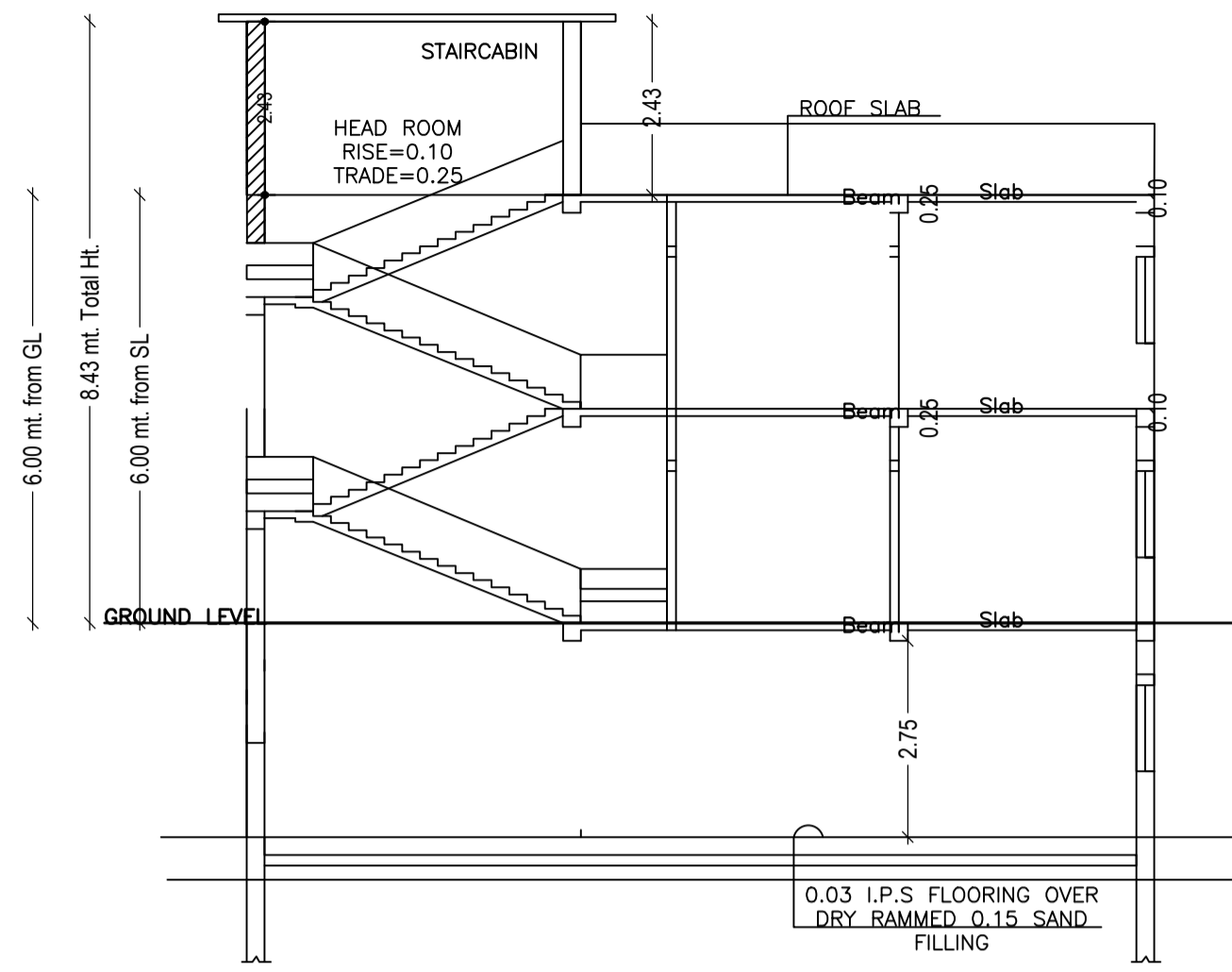

SECTION ON-XX

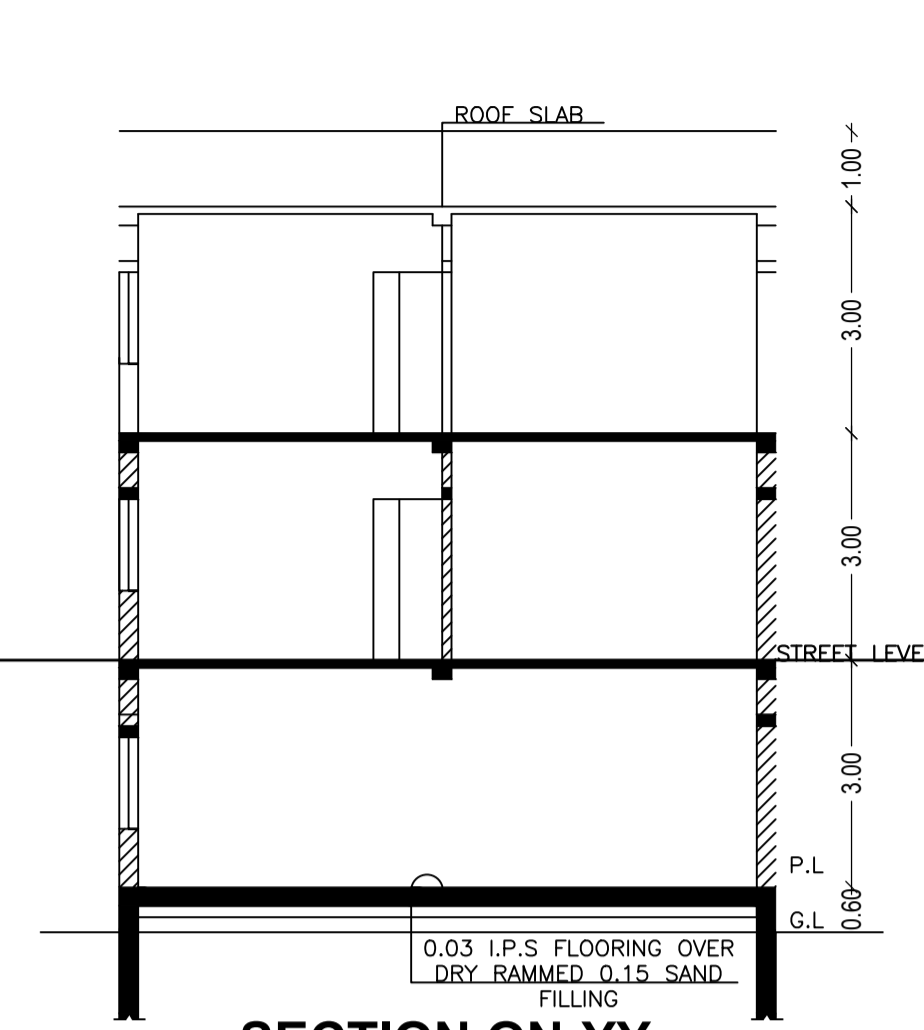

SECTION ON-YY

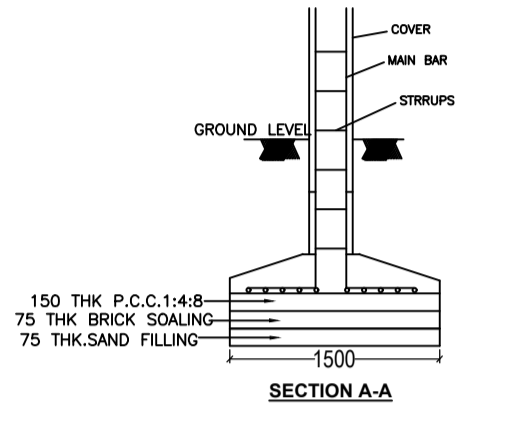
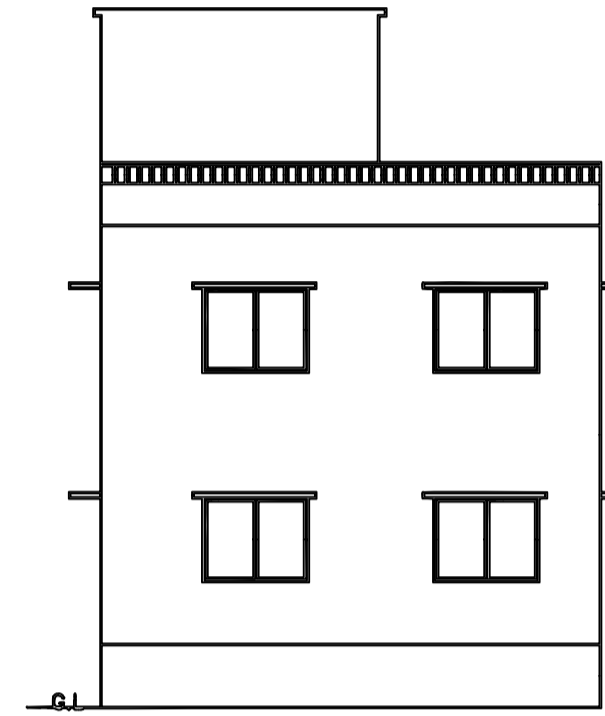

DETAIL OF FOUNDATION SCALE - N.T.S.

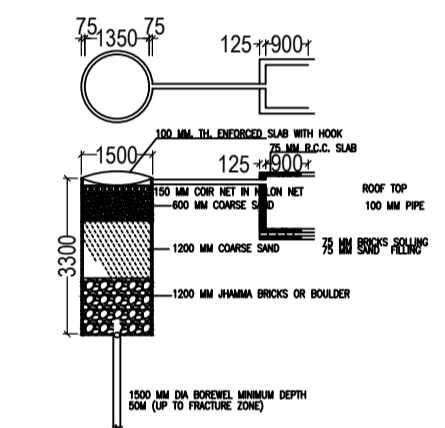

DETAIL OF GROUND WATER RECHARGING PIT WITH SILT TANK SCALE - N.T.S.

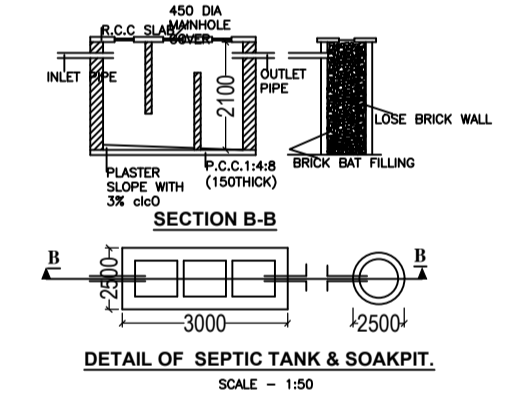

DETAIL OF SEPTIC TANK & SOAKPIT SCALE - 1:50

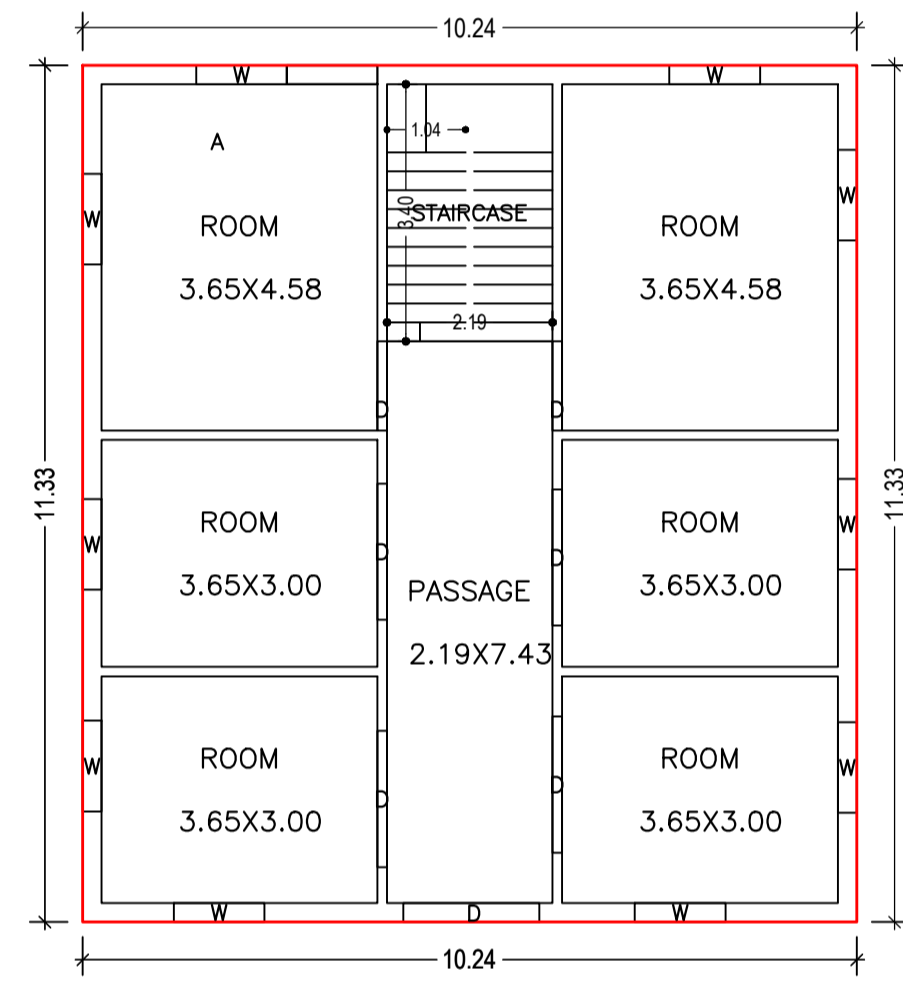

GROUND FLOOR PLAN (Proposed) (SCALE 1:100)

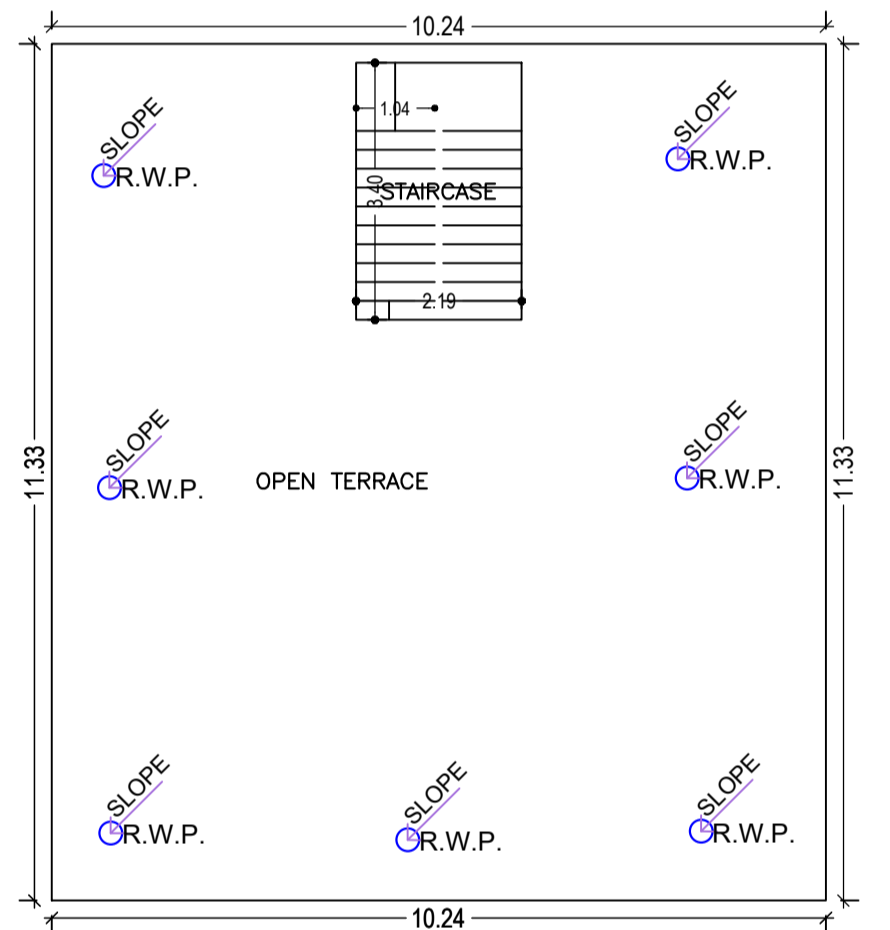

TERRACE FLOOR PLAN (SCALE 1:100)

Building :A (BUILDING)

Floor Name	Total Built Up Area (Sq.mt.)	Deductions (Area in Sq.mt.)			Proposed FAR Area (Sq.mt.)	Total FAR Area (Sq.mt.)	Total Consumed Additional FAR Area (Sq.mt.)	Trmt (No.)
		Parking	Resi.	Commercial				
Basement Floor	116.02	100.72	0.00	0.00	0.00	0.00	00	
Ground Floor	116.02	0.00	0.00	116.02	116.02	116.02	01	
First Floor	116.02	0.00	116.02	0.00	116.02	116.02	01	
Terrace Floor	0.00	0.00	0.00	0.00	0.00	0.00	00	
Total :	348.06	100.72	116.02	116.02	232.04	232.04	02	
Total Number of Same Buildings	1							
Total :	348.06	100.72	116.02	116.02	232.04	232.04	02	

SCHEDULE OF DOOR:

BUILDING NAME	NAME	LENGTH	HEIGHT	NOS
A (BUILDING)	D1	0.75	2.10	02
A (BUILDING)	D	0.90	2.10	08
A (BUILDING)	D	1.18	2.10	02
A (BUILDING)	D	1.80	2.10	05

SCHEDULE OF WINDOW/VENTILATION:

BUILDING NAME	NAME	LENGTH	HEIGHT	NOS
A (BUILDING)	V	0.90	0.60	01
A (BUILDING)	W	1.20	1.20	10
A (BUILDING)	W	1.38	1.20	01
A (BUILDING)	W	1.50	1.20	10

UnitBUA Table for Building :A (BUILDING)

FLOOR	Name	UnitBUA Type	UnitBUA Area	Carpet Area	No. of Rooms	No. of Tenement
GROUND FLOOR PLAN	A	SHOP	108.03	107.73	7	1
FIRST FLOOR PLAN	SPLIT A	FLAT	108.03	107.75	10	1
Total:	-	-	216.06	215.48	17	2

LTP NAME AND SIGNATURE	STRUCTURAL ENG'S NAME AND SIGNATURE	BUILDER NAME AND SIGNATURE	DIGITAL SIGNATURE
PANKAJ KUMAR SINGH MNNP/ENG/0006/2019			