

SITE PLAN

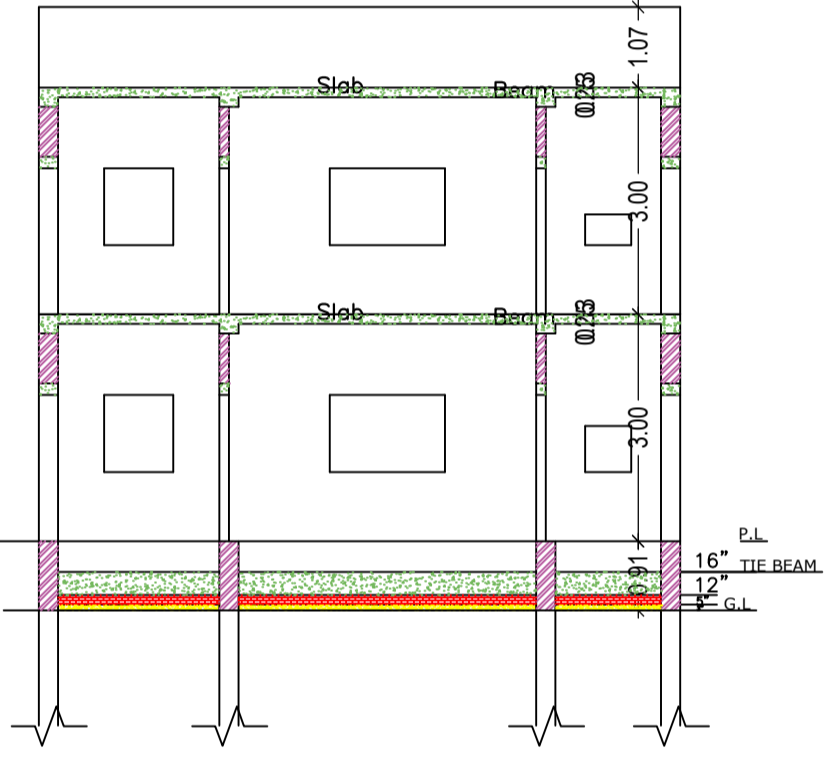
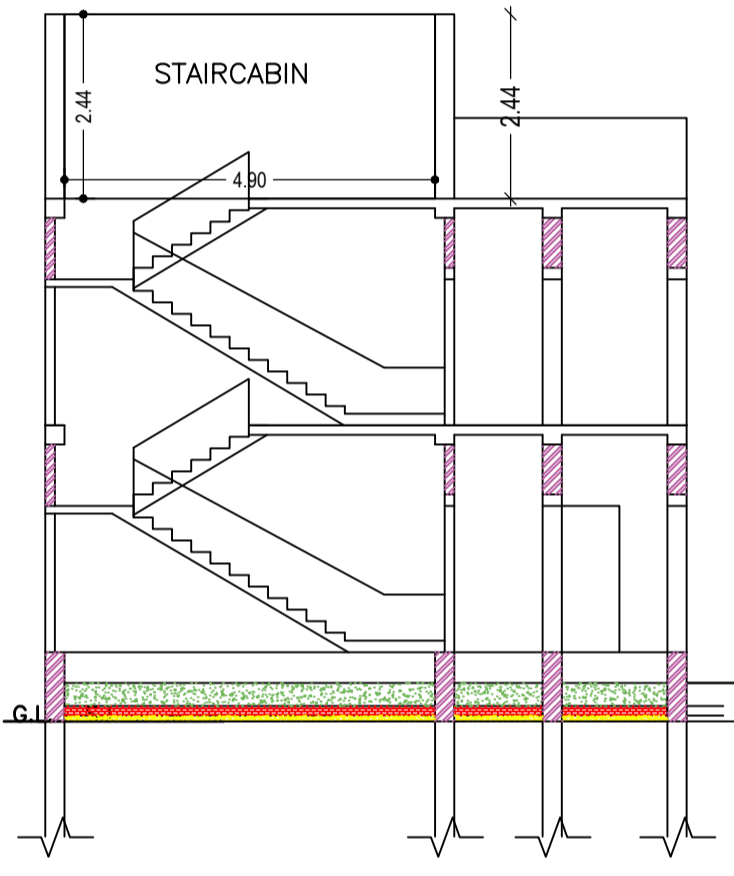
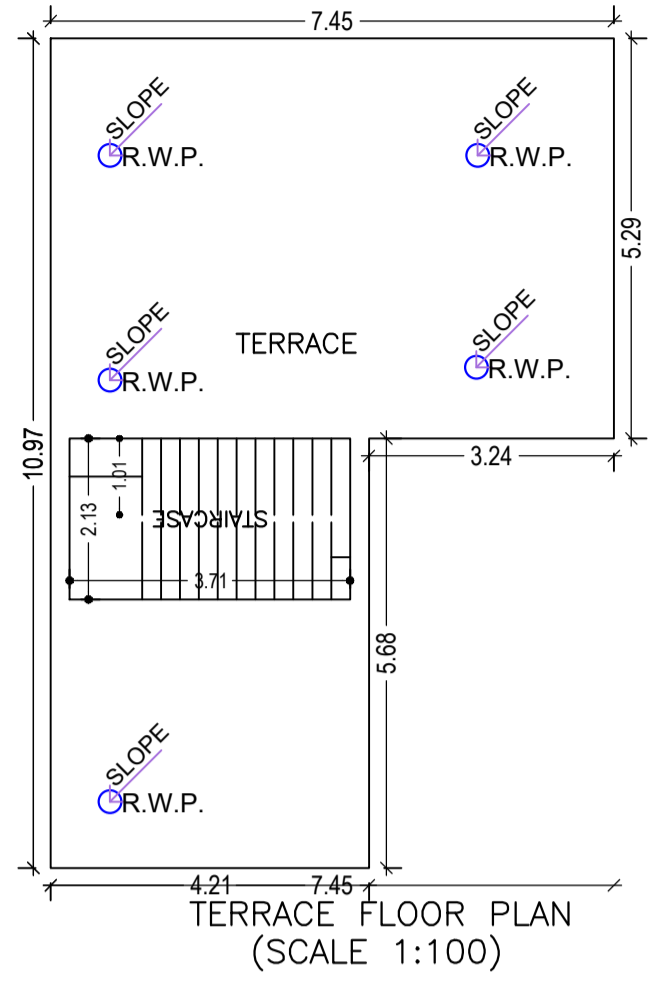
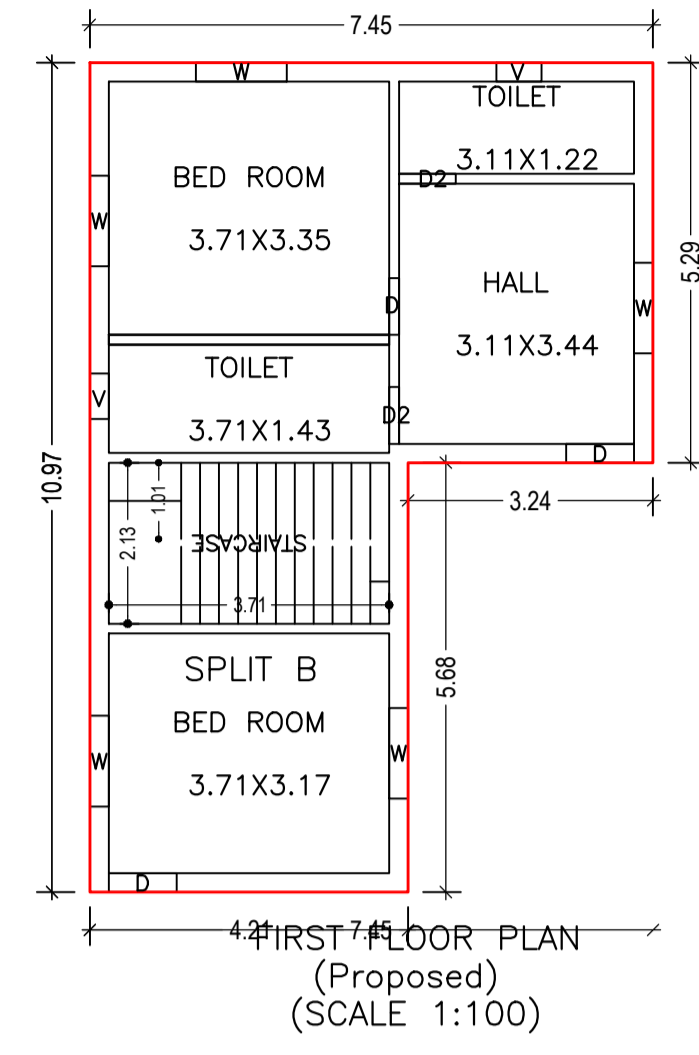
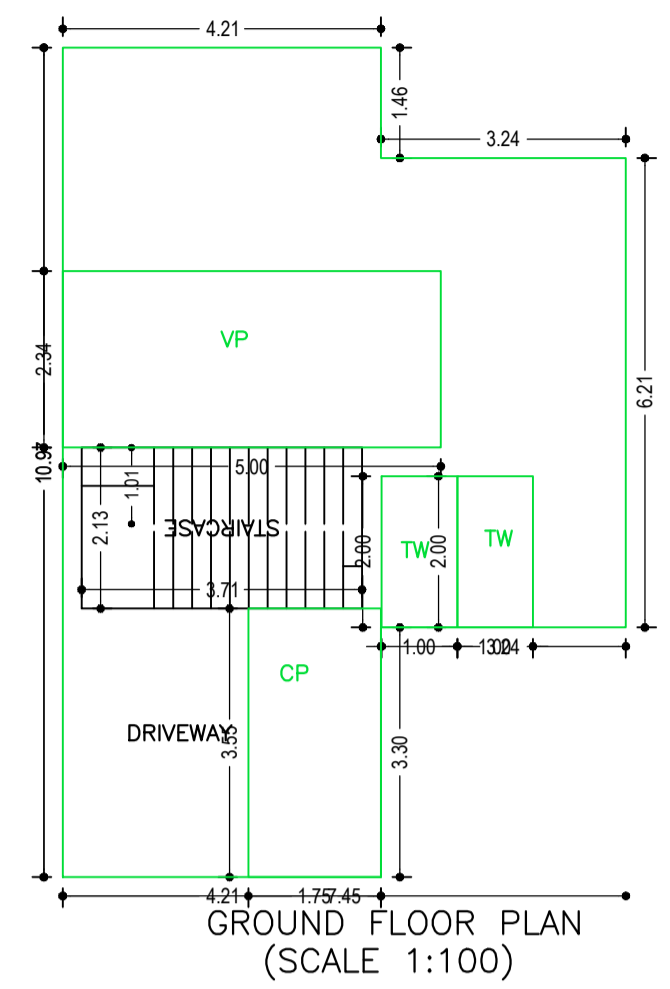
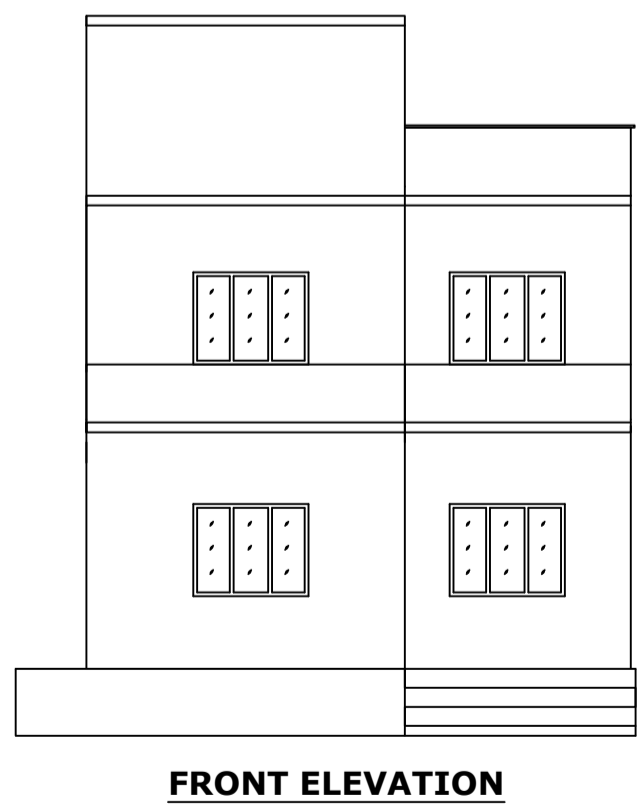
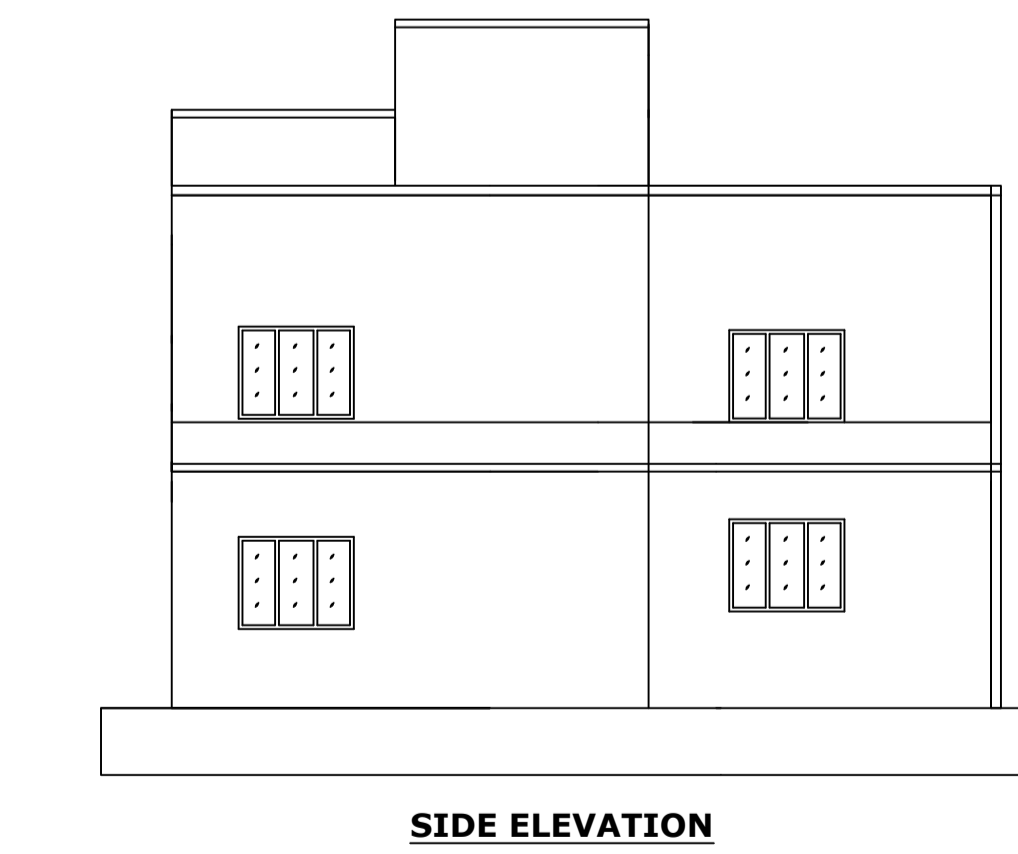

Building :A (RESIDENTIAL)

Floor Name	Total Built Up Area (Sq.mt)	Deductions (Area in Sq.mt)	Proposed FAR Area (Sq.mt)	Add Area In FAR (Sq.mt)	Total FAR Area (Sq.mt)	Total Consumed Additional FAR Area (Sq.mt)	Trmt (No.)
Ground Floor	66.30	58.40	0.00	7.90	7.90	7.90	00
First Floor	63.32	0.00	63.32	0.00	63.32	63.32	01
Terrace Floor	0.00	0.00	0.00	0.00	0.00	0.00	00
Total :	129.62	58.40	63.32	7.90	71.22	71.22	01

SCHEDULE OF DOOR:

BUILDING NAME	NAME	LENGTH	HEIGHT	NOS
A (RESIDENTIAL)	D	0.75	2.10	01
A (RESIDENTIAL)	D2	0.75	2.10	02
A (RESIDENTIAL)	D'	0.90	2.10	02

SCHEDULE OF WINDOW/VENTILATION:

BUILDING NAME	NAME	LENGTH	HEIGHT	NOS
A (RESIDENTIAL)	V	0.60	0.90	02
A (RESIDENTIAL)	W	1.20	1.20	05

UnitBUA Table for Building :A (RESIDENTIAL)

FLOOR	Name	UnitBUA Type	UnitBUA Area	Carpet Area	No. of Rooms	No. of Tenement
FIRST FLOOR PLAN	SPLIT B	FLAT	54.89	54.41	5	1
Total:	-	-	54.89	54.41	5	1

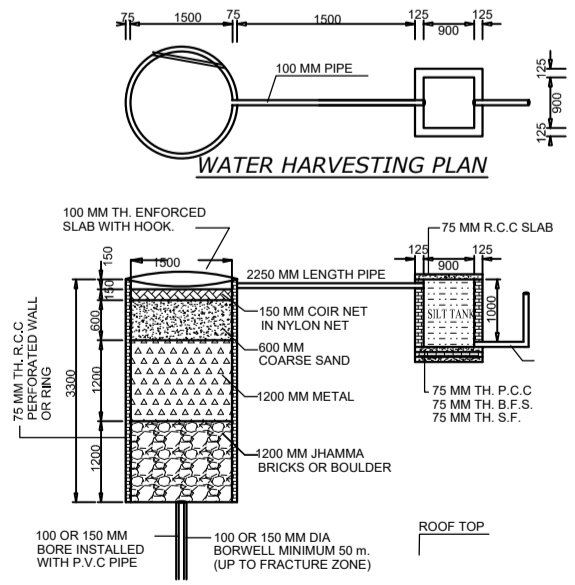
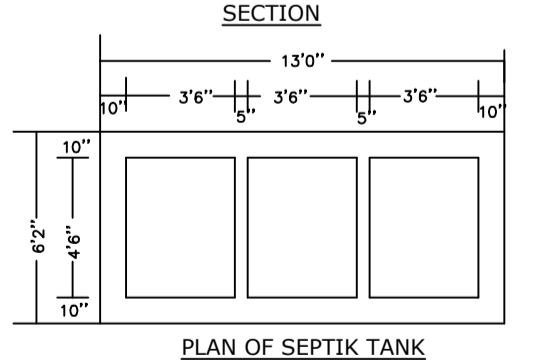
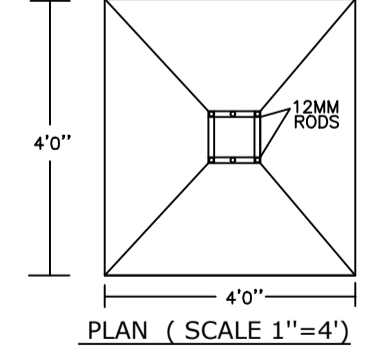
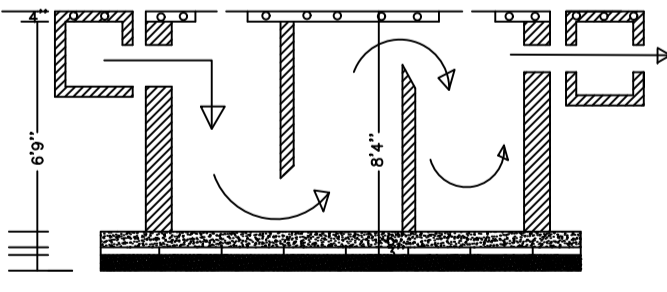
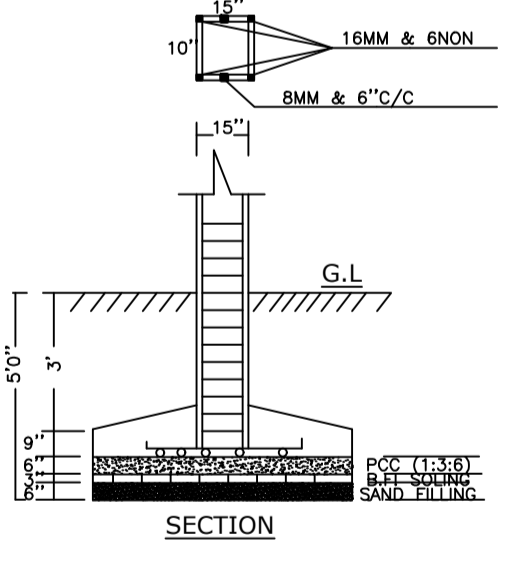

Proposal Basic Information

Proposal File No.	MNNP/BI/0300/W33/2022
Owner Name	Uttam George Tirkey
Khata No	230
Plot No	1061
Village Name	Nabatoli
Use	Residential
SubUse	Bungalow/ Dwelling / Non Apartment

AREA STATEMENT	VERSION NO. : 1.0.64	
MEDINNAGAR MUNICIPAL CORPORATION	VERSION DATE: 16/10/2020	
PROJECT DETAIL:		
Region: JHARKHAND URBAN LOCAL BODIES	Plot Use: Residential	
District: PALAMU	Plot SubUse: Bungalow/ Dwelling / Non Apartment	
Authority: MEDINNAGAR MUNICIPAL CORPORATION	PlotNearbyReligiousStructure: NA	
Inward No: MNNP/BI/0300/W33/2022	Plot/SubPlot No: 1061	
Application Type: General Proposal	North: -	
Project Type: Building Permission	South: -	
Nature of Development: New	East: -	
Location of Development Area: Old Area	West: -	
AREA DETAILS:		
AREA OF PLOT (Minimum)	(A)	SQ.MT.
		302.76
Deduction for NetPlot Area		
Surrender Free of Cost		15.94
Total		15.94
NET AREA OF PLOT (Gross Plot Area - Deduction from Gross Plot area)	(A-Deductions)	286.82
Deduction for Balance Plot Area (from Gross Plot Area)		
Surrender Free of Cost		15.94
Common Plot		56.43
Total		72.37
BALANCE AREA OF PLOT (Net Plot Area - Recreational/Amenity space)	(A-Deductions)	230.39
PLOT AREA FOR COVERAGE (Net Plot Area)	(A-Deductions)	286.82
Plot Area for FAR (Net Plot Area + Road Widening Area)	(A-Deductions)	302.76
COVERAGE CHECK		
Permissible Coverage area ( 60.00 % )		172.09
Proposed Coverage Area ( 23.12 % )		66.30
Total Prop. Coverage Area ( 23.12 % )		66.30
Balance coverage area ( 36.88 % )		105.79
FAR CHECK		
Perm. FAR Area ( 1.50 )		454.14
Total Perm. FAR area		454.14
Residential FAR		63.32
Proposed FAR Area		71.23
Total Proposed FAR Area		71.23
Consumed FAR (Factor)		0.24
Balance FAR Area		382.91
BUILT UP AREA CHECK		
Total Proposed BuiltUp Area		129.62
ARCHITECT (Regd)		RANJIT KUMAR
ENGINEER (Regd)		
SUPERVISOR (Regd)		
OWNER (Regd)		Uttam George Tirkey
DEVELOPMENT AUTHORITY		LOCAL BODY

COLOR INDEX

PLOT BOUNDARY	Black
ABUTTING ROAD	Red
PROPOSED CONSTRUCTION	Green
COMMON PLOT	Yellow
ROAD WIDENING AREA	Orange
EXISTING (To be retained)	Blue
EXISTING (To be demolished)	Light Blue

Buildingwise Floor FAR Details

Floor Name	Building Name A (RESIDENTIAL)		Total	
	Proposed Built Up Area (Sq.mt.)	Proposed FAR Area (Sq.mt.)	Total Proposed Built Up Area (Sq.mt.)	Total FAR Area (Sq.mt.)
Ground Floor	66.30	7.90	66.30	7.90
First Floor	63.32	63.32	63.32	63.32
Terrace Floor	0.00	0.00	0.00	0.00
Total :	129.62	71.22	129.62	71.22

Building USE/SUBUSE Details

Building Name	Building Use	Building SubUse	Building Structure
A (RESIDENTIAL)	Residential	Bungalow/ Dwelling / Non Apartment	Non-Highrise

FAR & Tenement Details (Table 4c-1)

Building	No. of Same Bldg	Total Built Up Area (Sq.mt.)	Deductions (Area in Sq.mt.)	Proposed FAR Area (Sq.mt.)	Add Area In FAR (Sq.mt.)	Total FAR Area (Sq.mt.)	Total Consumed Additional FAR Area (Sq.mt.)	Trmt (No.)
A (RESIDENTIAL)	1	129.62	58.40	63.32	7.90	71.22	71.22	01
Grand Total :	1	129.62	58.40	63.32	7.90	71.22	71.22	01

LTP NAME AND SIGNATURE	STRUCTURAL ENG'S NAME AND SIGNATURE	BUILDER NAME AND SIGNATURE	DIGITAL SIGNATURE
RANJIT KUMAR MNNP/ENG/0001/2016			