

2 FRONT ELEVATION
1: 150

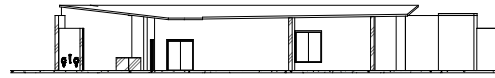

1 SECTION B-B
1: 150

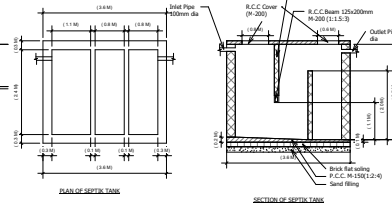

3 SEPTIC TANK
1: 60

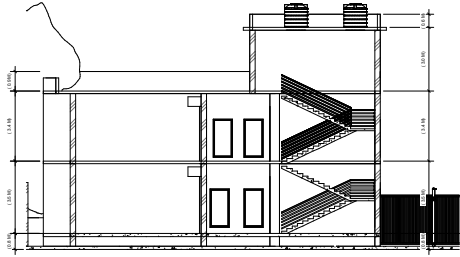

10 SECTION A-A
1: 100

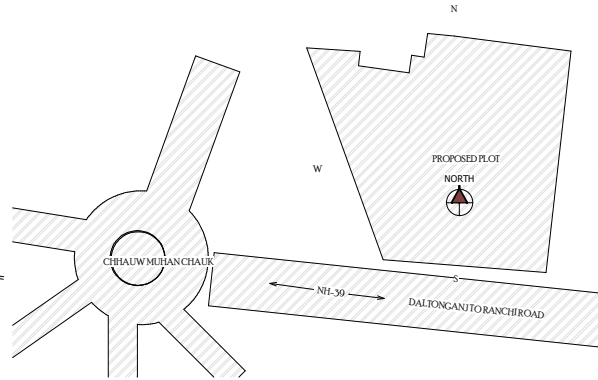

4 LOCATION PLAN
1: 300

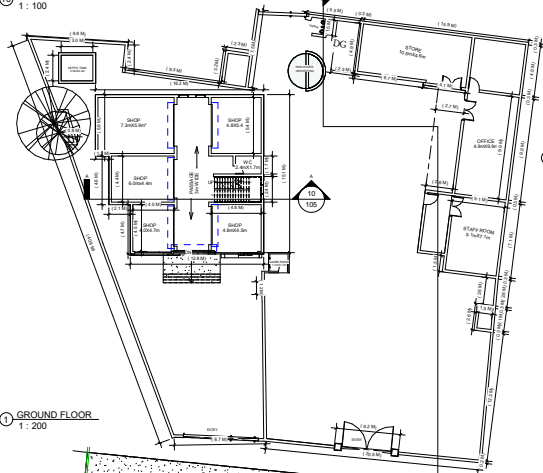

1 GROUND FLOOR
1: 200

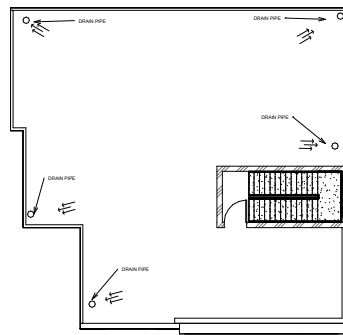

5 TERRACE
1: 300

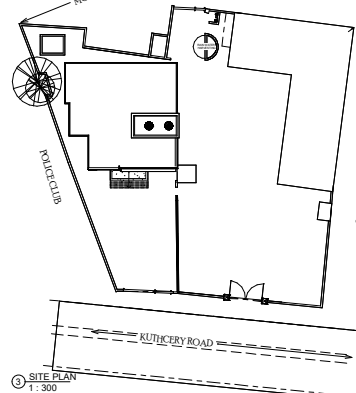

3 SITE PLAN
1: 500

6 RAIN WATER HARVESTING
1: 70

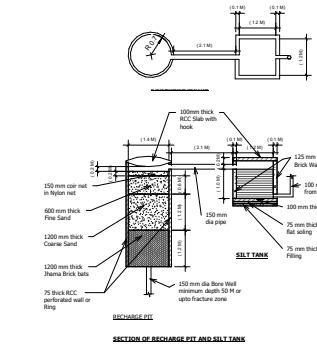

SECTION OF RECHARGE PIT AND SILT TANK

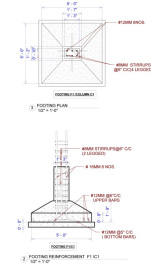

5 FOUNDATION DETAIL
1: 120

Schedule of openings

Door Schedule			
Type	Width	Height	Count
120"X90"	3.7	2.7	6
120"X90"	4.0	2.7	5
30" x 84"	0.8	2.1	1
36" x 84"	0.9	2.1	1
42"X84"	1.1	2.1	4
72"X84"	1.8	2.1	2
Door-External or-Double	1.8	2.1	1
Grand total: 20			

Window Schedule			
Type Mark	Width	Height	Sill Height
W	0.6	0.6	1.6
W	0.9	1.8	0.3
W1	0.9	1.2	0.9
Grand total: 9			

1. ALL STRUCTURE TO BE CONSTRUCTED AS PER STRUCTURAL DRAWING.

2. ALL CONCRETE TO BE CASTED IN PLACE.

3. ALL BRICKWORK TO BE CONSTRUCTED AS PER DRAWING.

4. ALL ROOFING TO BE CONSTRUCTED AS PER DRAWING.

5. ALL PAINTING TO BE CONSTRUCTED AS PER DRAWING.

6. ALL ELECTRICAL AND MECHANICAL TO BE CONSTRUCTED AS PER DRAWING.

7. ALL SANITARY AND PLUMBING TO BE CONSTRUCTED AS PER DRAWING.

8. ALL LANDSCAPING TO BE CONSTRUCTED AS PER DRAWING.

9. ALL FENCING TO BE CONSTRUCTED AS PER DRAWING.

10. ALL UTILITIES TO BE CONSTRUCTED AS PER DRAWING.

11. ALL OTHER WORKS TO BE CONSTRUCTED AS PER DRAWING.

OWNER'S NAME:-
RATAN LALL PRAKASH CHAND,
DALTONGANJ, PALAMU

PROJECT ADDRESS:-
EXISTING BUILDING PLAN CHALMERIAN
CHALK, DALTONGANJ, PALAMU,
JHARKHAND

Scale: As indicated

Project number: CS/20/1022 Date: Issue Date

Drawn: NORTH

Scale: As indicated

ENGINEER SIGNATURE OWNER'S SIGNATURE

15/06/2022 12:27:29 PM