

FAR & Tenement Details (Table 4c-1)

Building	No. of Same Bldg	Total Built Up Area (Sq.mt.)	Proposed FAR Area (Sq.mt.) Resi.	Total FAR Area (Sq.mt.)	Total Consumed Additional FAR Area (Sq.mt.)	Tnmt (No.)
A (RESIDENTIAL)	1	55.28	55.28	55.28	55.28	01
Grand Total :	1	55.28	55.28	55.28	55.28	01

Proposal Basic Information

Proposal File No.	MNNP/BP/0313/W08/2022
Owner Name	Lalita Devi and Lalti Devi
Khata No	23
Plot No	150,151
Village Name	Baralota
Use	Residential
SubUse	Bungalow/ Dwelling / Non Apartment

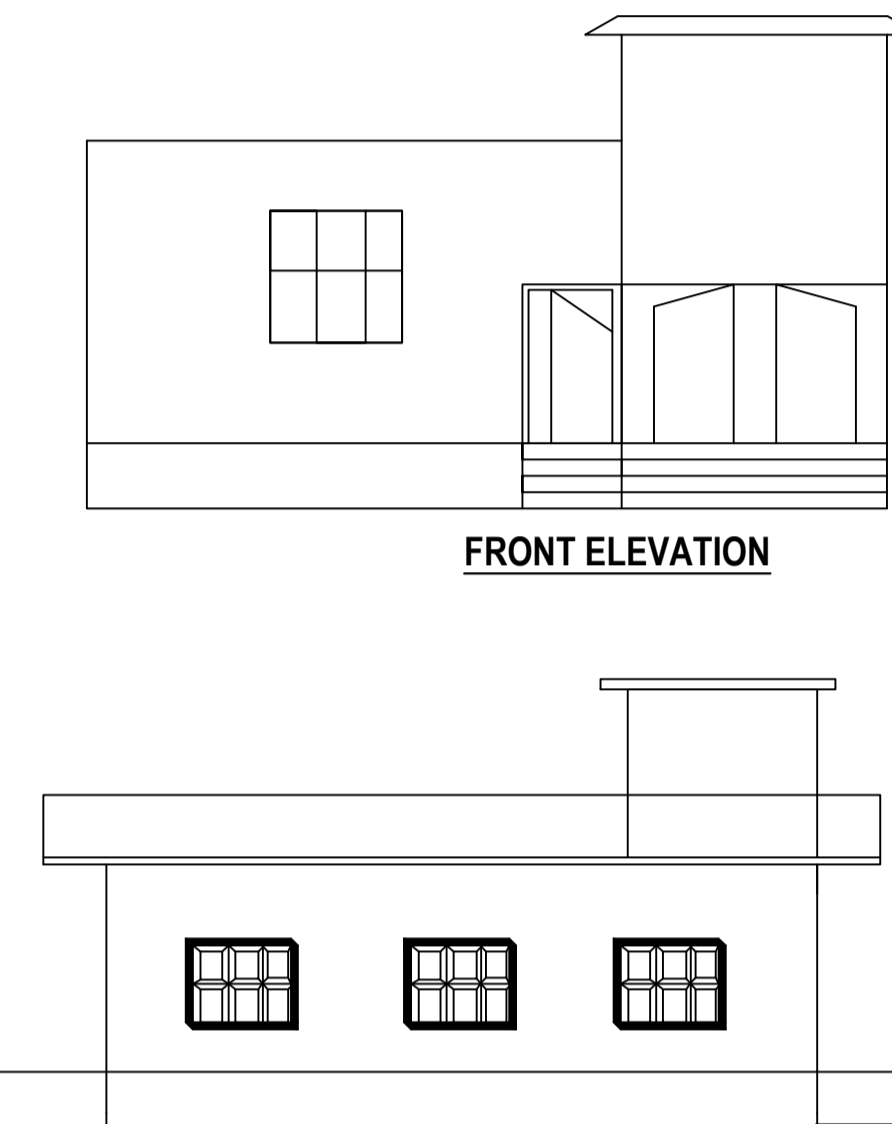

AREA STATEMENT		VERSION NO. : 1.0.64
MEDININAGAR MUNICIPAL CORPORATION		VERSION DATE: 16/10/2020
PROJECT DETAIL:		
Region: JHARKHAND URBAN LOCAL BODIES	Plot Use: Residential	
District: PALAMU	Plot SubUse: Bungalow/ Dwelling / Non Apartment	
Authority: MEDININAGAR MUNICIPAL CORPORATION	PlotNearbyReligiousStructure: NA	
Inward No: MNNP/BP/0313/W08/2022	Plot/SubPlot No: 150,151	
Application Type: General Proposal	North: -	
Project Type: Building Permission	South: -	
Nature of Development: New	East: -	
Location of Development Area: Old Area	West: -	
AREA DETAILS:		SQ.MT.
AREA OF PLOT (Minimum)	(A)	161.30
Deduction for NetPlot Area		
Surrender Free of Cost		15.28
Total		15.28
NET AREA OF PLOT(Gross Plot Area - Deduction from Gross Plot area)	(A-Deductions)	146.02
Deduction for Balance Plot Area(from Gross Plot Area)		
Surrender Free of Cost		15.28
Common Plot		15.08
Total		30.35
BALANCE AREA OF PLOT(Net Plot Area - Recreational/Amenity space)	(A-Deductions)	130.95
PLOT AREA FOR COVERAGE(Net Plot Area)	(A-Deductions)	146.02
Plot Area for FAR (Net Plot Area + Road/Widening Area)	(A-Deductions)	161.30
COVERAGE CHECK		
Permissible Coverage area (70.00 %)		102.21
Proposed Coverage Area (37.86 %)		55.28
Total Prop. Coverage Area (37.86 %)		55.28
Balance coverage area (32.14 %)		46.93
FAR CHECK		
Perm. FAR Area (1.20)		193.56
Total Perm. FAR area		193.56
Residential FAR		55.28
Proposed FAR Area		55.28
Total Proposed FAR Area		55.28
Consumed FAR (Factor)		0.34
Balance FAR Area		138.28
BUILT UP AREA CHECK		
Total Proposed BuiltUp Area		55.28
ARCHITECT (Regd)	RANJIT KUMAR	
ENGINEER (Regd)		
SUPERVISOR (Regd)		
OWNER (Regd)	Lalita Devi and Lalti Devi	
DEVELOPMENT AUTHORITY		LOCAL BODY

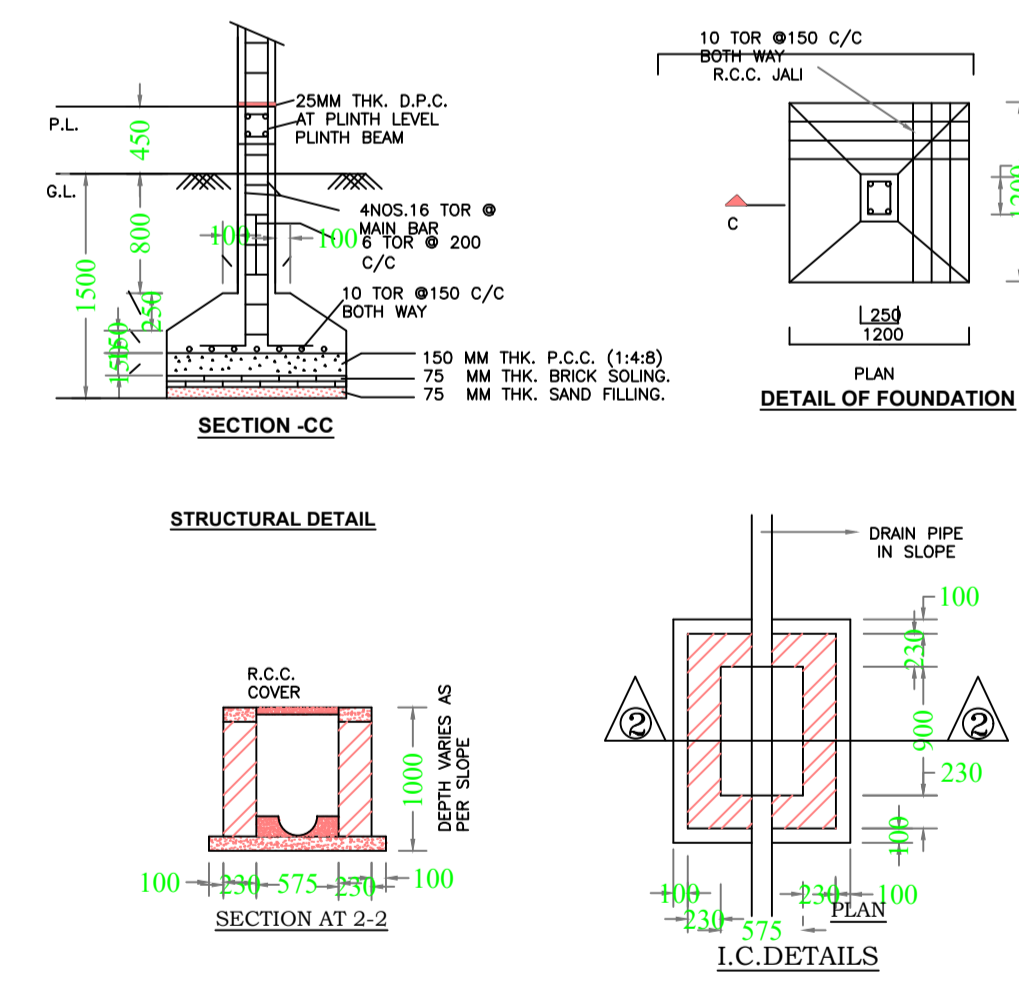

COLOR INDEX	
PLOT BOUNDARY	Black
ABUTTING ROAD	Green
PROPOSED CONSTRUCTION	Red
COMMON PLOT	Yellow
ROAD WIDENING AREA	Blue
EXISTING (To be retained)	Orange
EXISTING (To be demolished)	Grey

Buildingwise Floor FAR Details

Floor Name	Building Name A (RESIDENTIAL)		Total	
	Proposed Built Up Area (Sq.mt.)	Proposed FAR Area (Sq.mt.)	Total Proposed Built Up Area (Sq.mt.)	Total FAR Area (Sq.mt.)
Ground Floor	55.28	55.28	55.28	55.28
Terrace Floor	0.00	0.00	0.00	0.00
Total :	55.28	55.28	55.28	55.28

Building USE/SUBUSE Details

Building Name	Building Use	Building SubUse	Building Structure
A (RESIDENTIAL)	Residential	Bungalow/ Dwelling / Non Apartment	Non-Highrise

Building :A (RESIDENTIAL)

Floor Name	Total Built Up Area (Sq.mt.)	Proposed FAR Area (Sq.mt.) Resi.	Total FAR Area (Sq.mt.)	Total Consumed Additional FAR Area (Sq.mt.)	Tnmt (No.)
Ground Floor	55.28	55.28	55.28	55.28	01
Terrace Floor	0.00	0.00	0.00	0.00	00
Total :	55.28	55.28	55.28	55.28	01
Total Number of Same Buildings	1				
Total :	55.28	55.28	55.28	55.28	01

SCHEDULE OF DOOR:

BUILDING NAME	NAME	LENGTH	HEIGHT	NOS
A (RESIDENTIAL)	D2	0.76	2.10	01
A (RESIDENTIAL)	D	0.76	2.10	02
A (RESIDENTIAL)	D1	0.76	2.10	01
A (RESIDENTIAL)	D	0.90	2.10	01

SCHEDULE OF WINDOW/VENTILATION:

BUILDING NAME	NAME	LENGTH	HEIGHT	NOS
A (RESIDENTIAL)	V	0.90	0.60	01
A (RESIDENTIAL)	W	0.95	1.20	01
A (RESIDENTIAL)	W	1.21	1.20	02
A (RESIDENTIAL)	W	1.80	1.20	03

UnitBUA Table for Building :A (RESIDENTIAL)

FLOOR	Name	UnitBUA Type	UnitBUA Area	Carpet Area	No. of Rooms	No. of Tenement
GROUND FLOOR PLAN	SPLIT A	FLAT	45.16	45.00	5	1
Total:	-	-	45.16	45.00	5	1

LTP NAME AND SIGNATURE	STRUCTURAL ENG'S NAME AND SIGNATURE	BUILDER NAME AND SIGNATURE	DIGITAL SIGNATURE
RANJIT KUMAR MNNP/ENG/0001/2016			