

Proposal Basic Information

Proposal File No.	MNNP/BP/0315/W04/2022
Owner Name	Vimla Devi
Khata No	320
Plot No	1625/14
Village Name	Baralota
Use	Residential
SubUse	Bungalow/ Dwelling / Non Apartment

AREA STATEMENT MEDINAGAR MUNICIPAL CORPORATION	VERSION NO.: 1.0.65 VERSION DATE: 16/10/2020	
PROJECT DETAIL:		
Region: JHARKHAND URBAN LOCAL BODIES	Plot Use: Residential	
District: PALAMU	Plot SubUse: Bungalow/ Dwelling / Non Apartment	
Authority: MEDINAGAR MUNICIPAL CORPORATION	PlotNearby/ReligiousStructure: NA	
Inward No: MNNP/BP/0315/W04/2022	Plot/SubPlot No: 1625/14	
Application Type: General Proposal	North: -	
Project Type: Building Permission	South: -	
Nature of Development: New	East: -	
Location of Development Area: Old Area	West: -	
AREA DETAILS:		SQ.MT.
AREA OF PLOT (Minimum)	(A)	302.84
Deduction for NetPlot Area		
Surrender Free of Cost		23.26
Total		23.26
NET AREA OF PLOT(Gross Plot Area - Deduction from Gross Plot area)	(A-Deductions)	279.58
Deduction for Balance Plot Area(from Gross Plot Area)		
Surrender Free of Cost		23.26
Common Plot		63.14
Total		86.39
BALANCE AREA OF PLOT(Net Plot Area - Recreational/Amenity space)	(A-Deductions)	216.45
PLOT AREA FOR COVERAGE(Net Plot Area)	(A-Deductions)	279.58
Plot Area for FAR (Net Plot Area + Road/Widening Area)	(A-Deductions)	302.84
COVERAGE CHECK		
Permissible Coverage area ( 60.00 % )		167.75
Proposed Coverage Area ( 46.26 % )		129.33
Total Prop. Coverage Area ( 46.26 % )		129.33
Balance coverage area ( 13.74 % )		38.42
FAR CHECK		
Perm. FAR Area ( 1.500 )		454.26
Total Perm. FAR area		454.26
Residential FAR		168.52
Proposed FAR Area		168.52
Total Proposed FAR Area		168.52
Consumed FAR (Factor)		0.56
Balance FAR Area		285.74
BUILT UP AREA CHECK		
Total Proposed BuiltUp Area		258.66
ARCHITECT (Regd)		RANJIT KUMAR
ENGINEER (Regd)		
SUPERVISOR (Regd)		
OWNER (Regd)		Vimla Devi
DEVELOPMENT AUTHORITY		LOCAL BODY

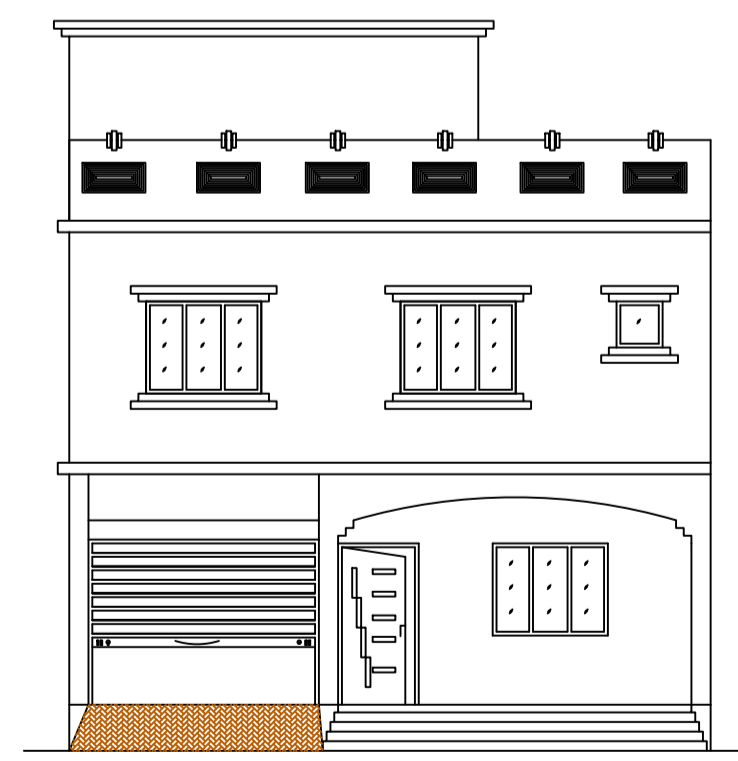
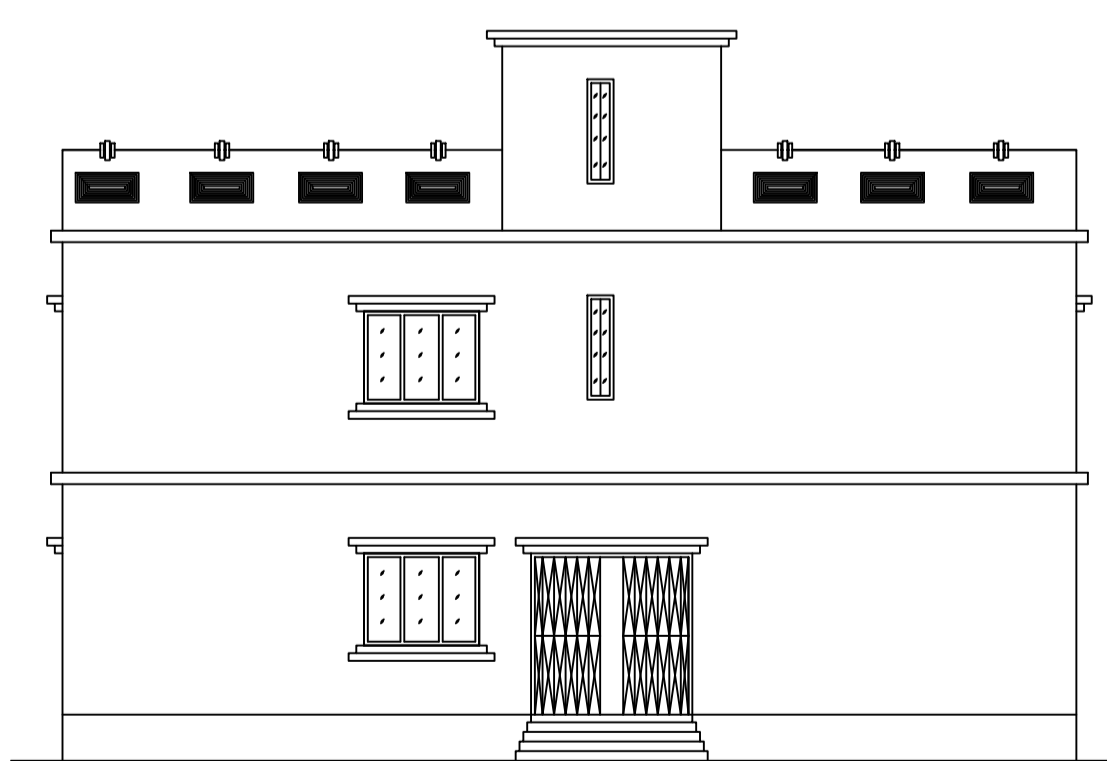
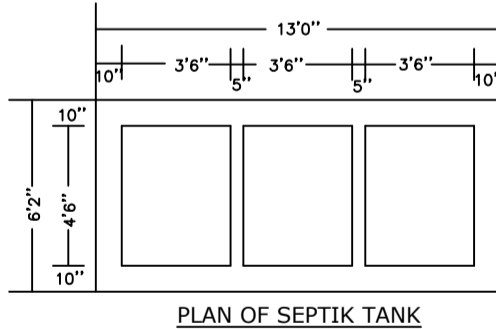
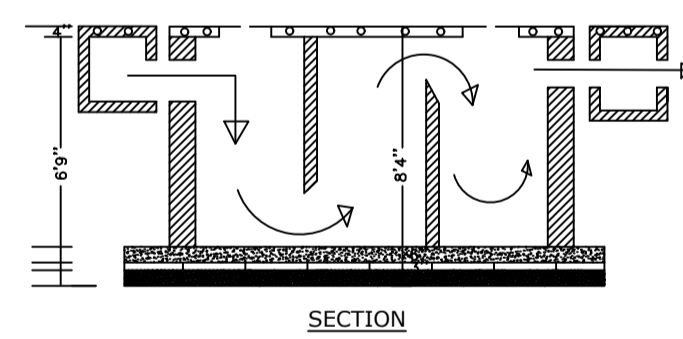
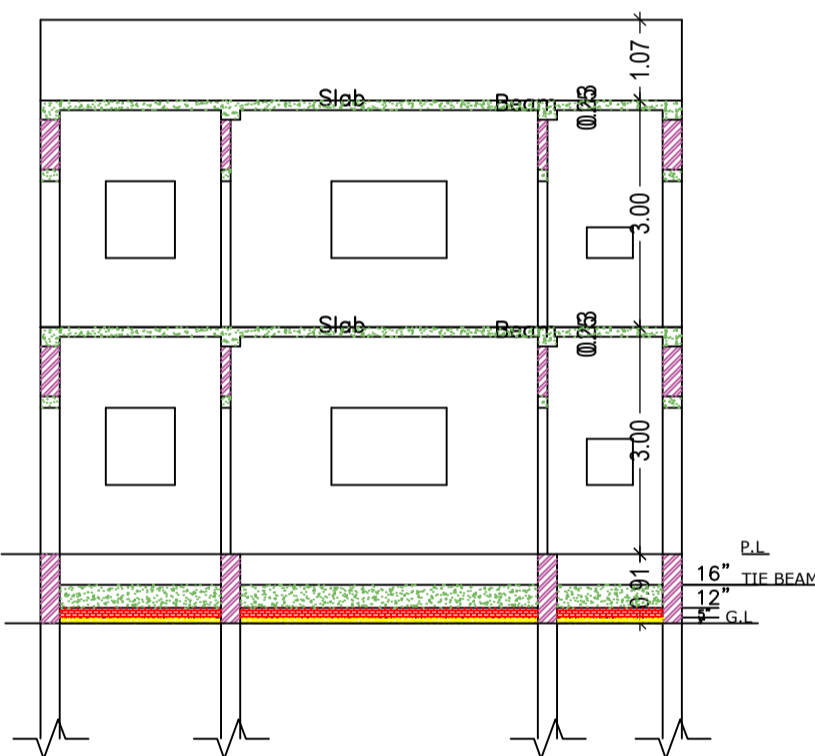
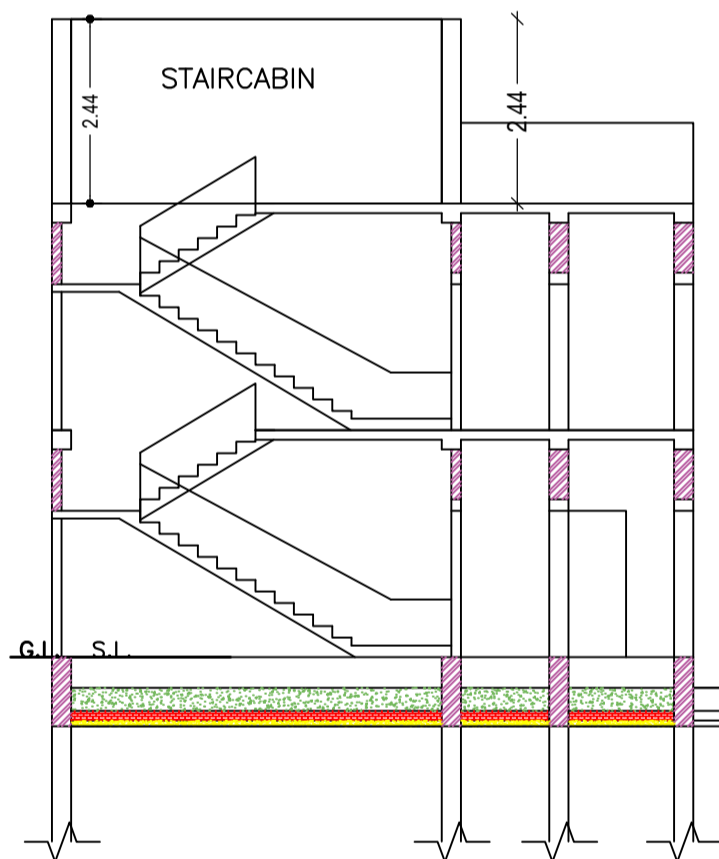
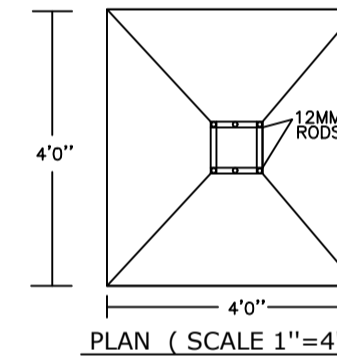
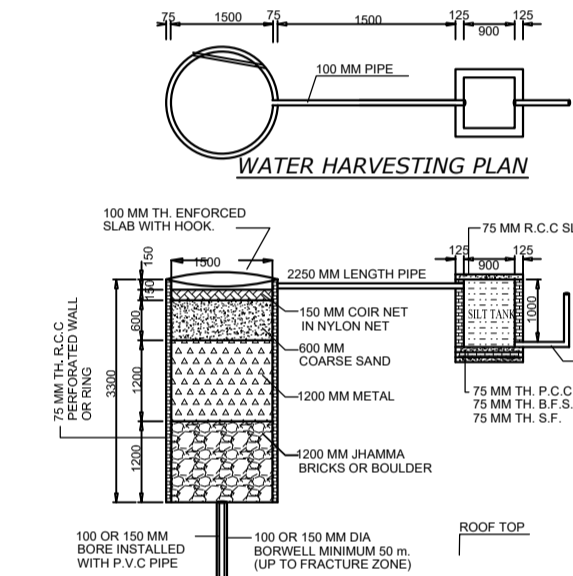
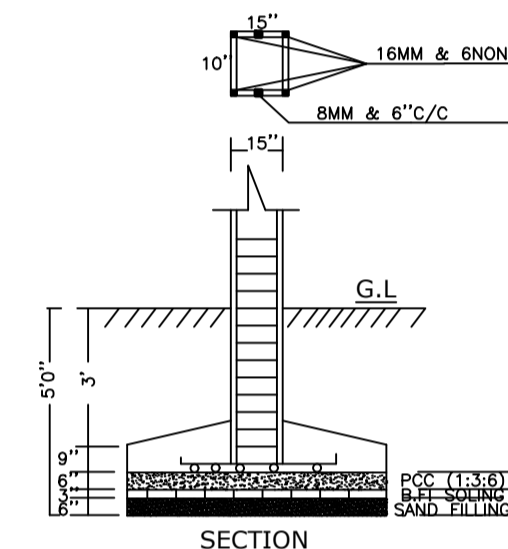
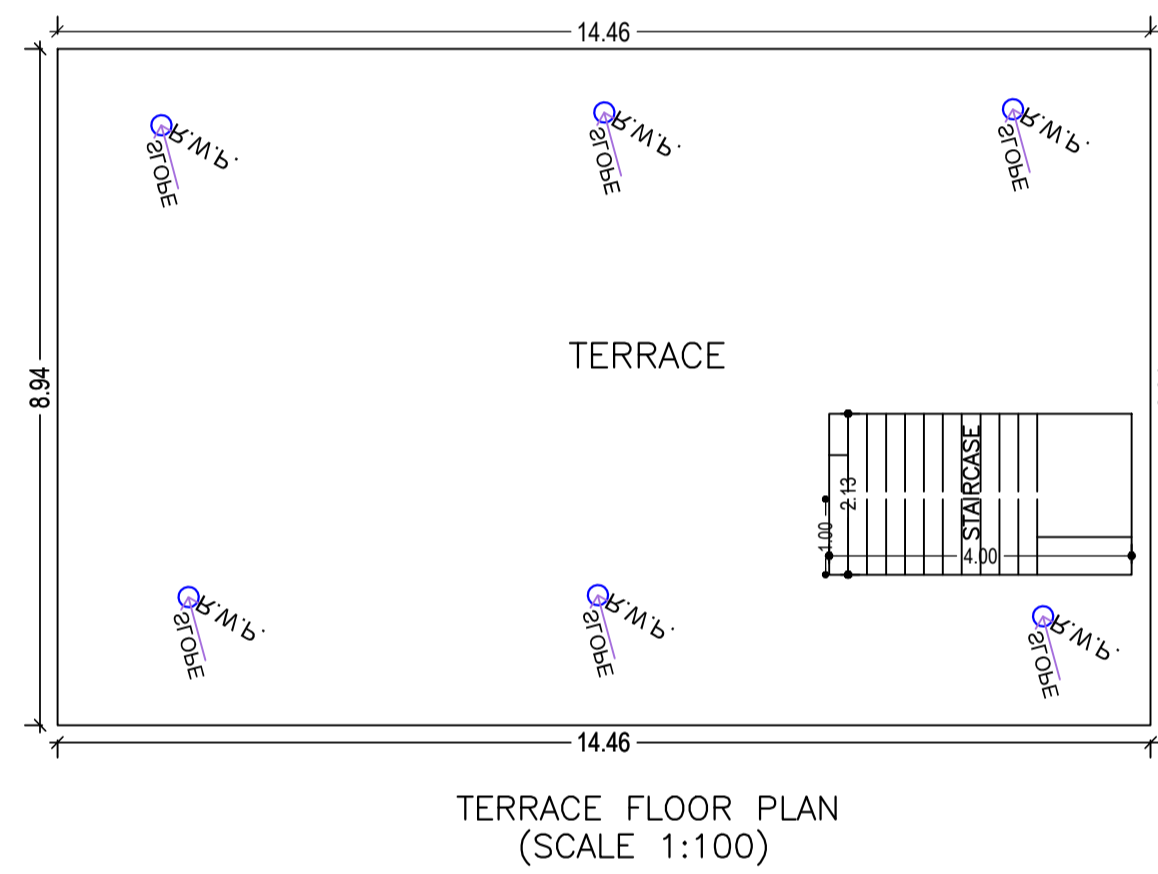
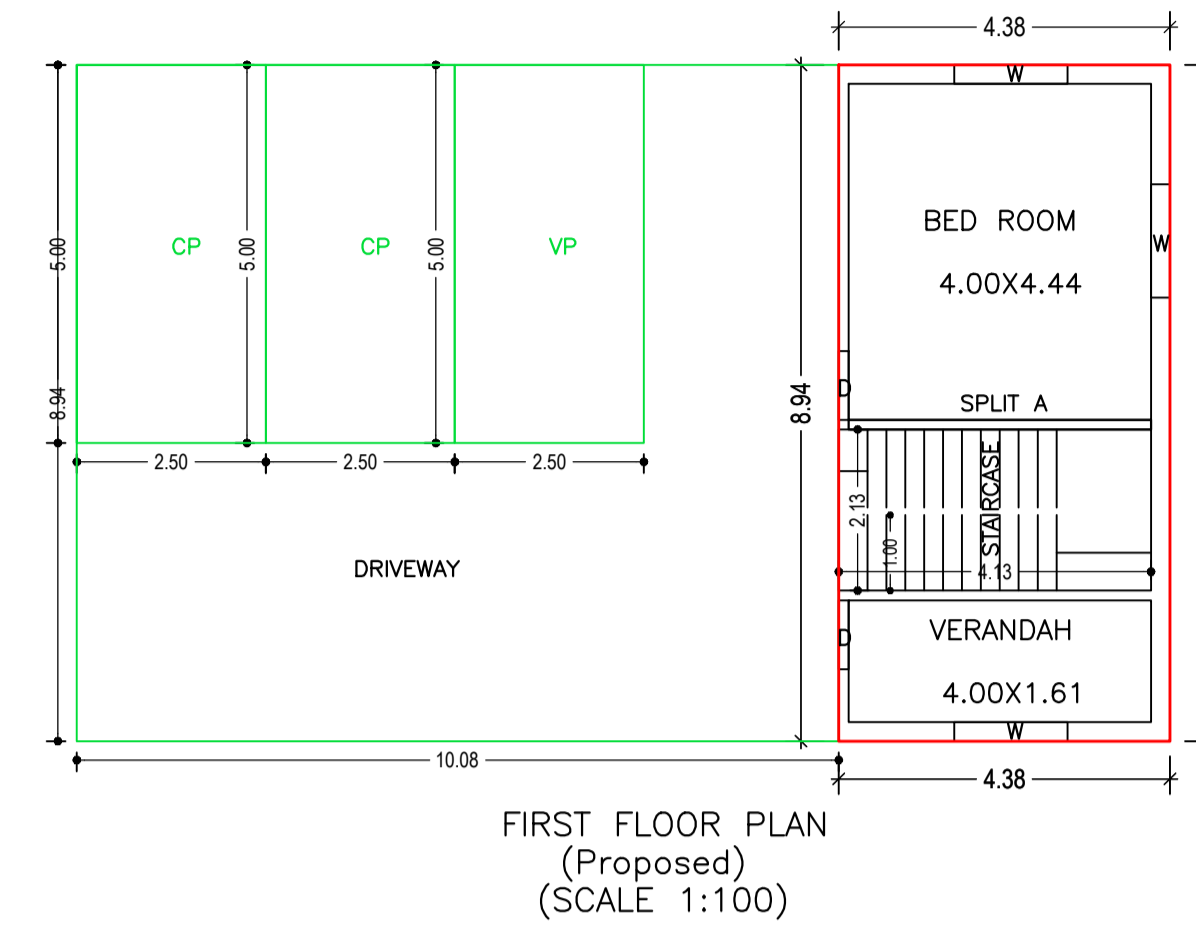
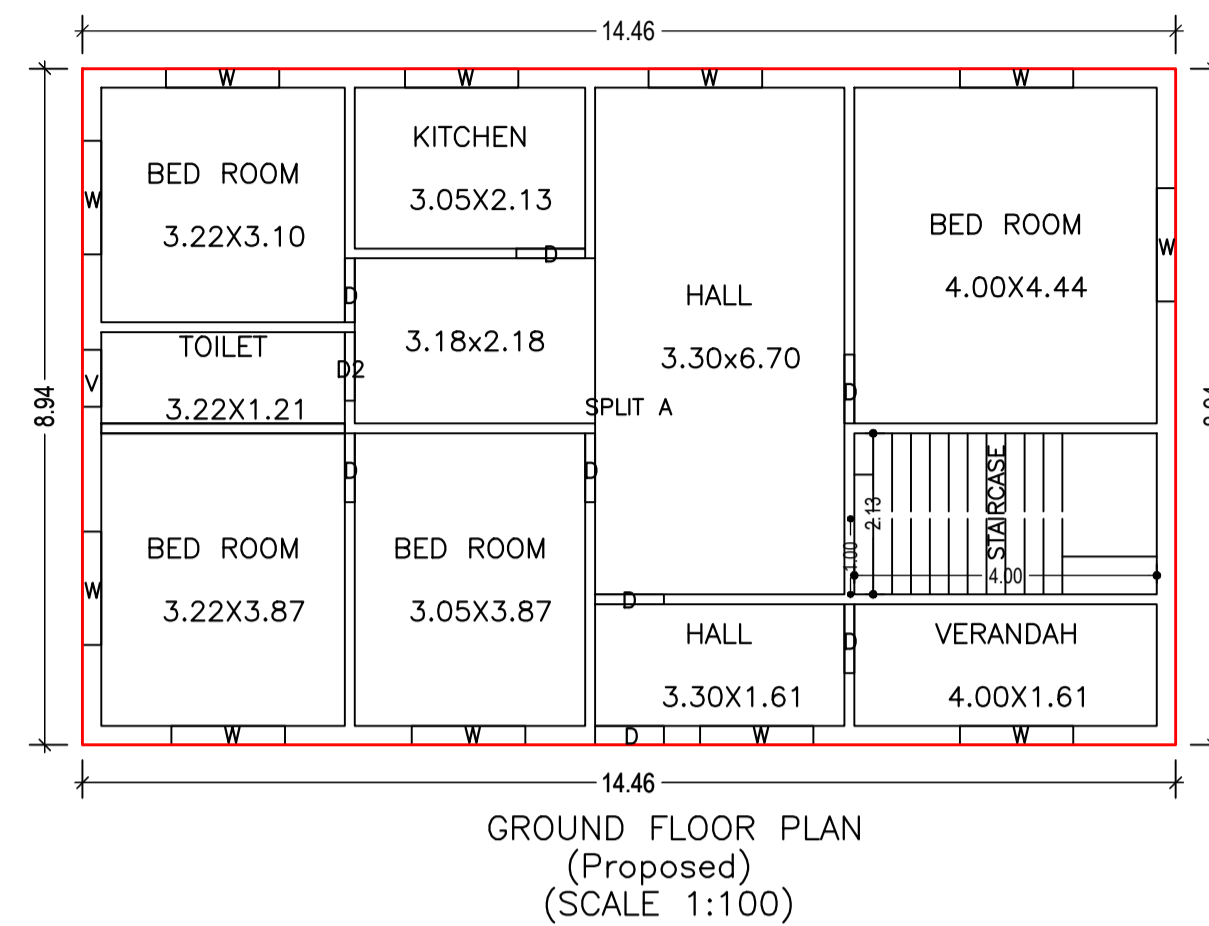
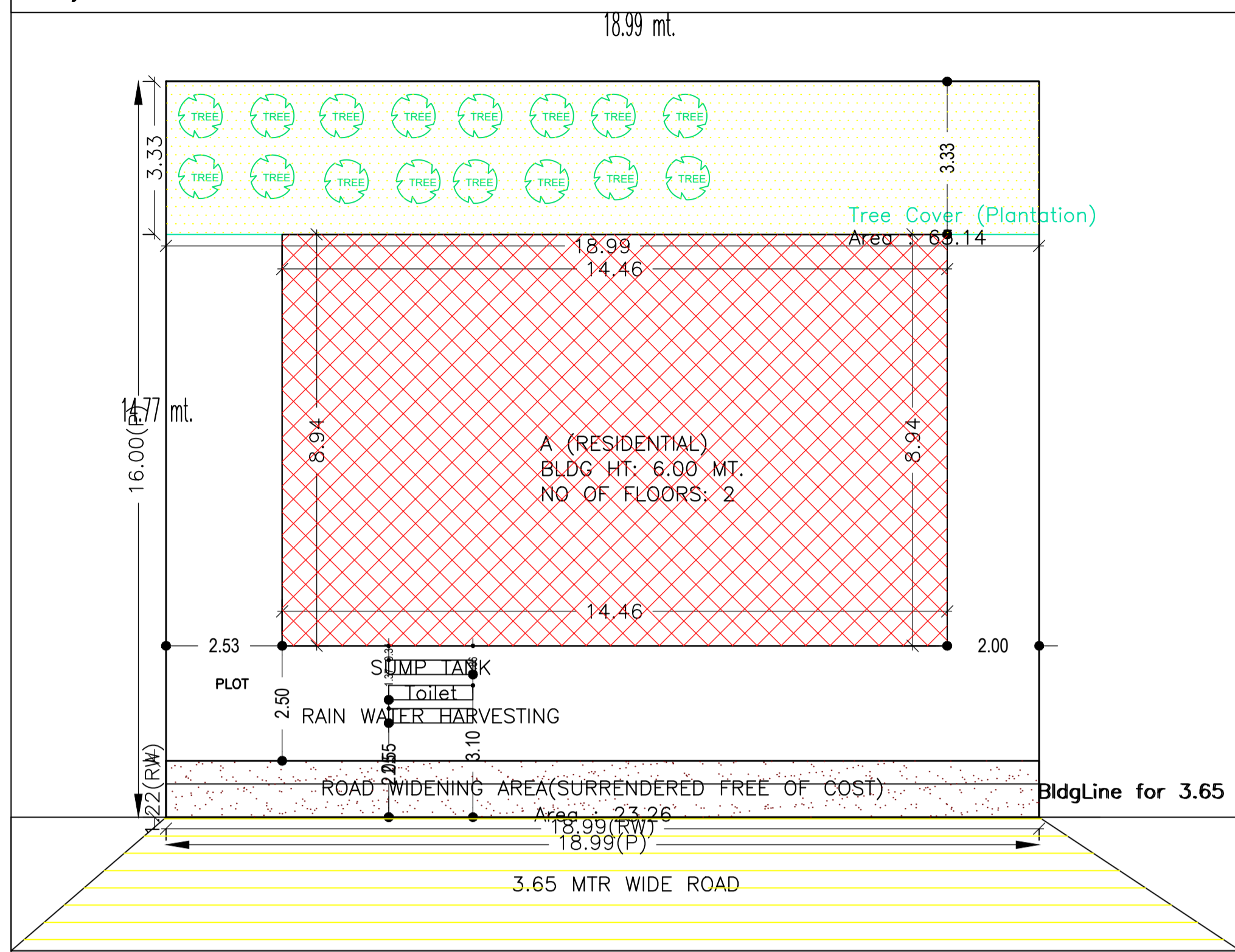

FRONT ELEVATION FAR & Tenement Details (Table 4c-1)

Building	No. of Same Bldg	Total Built Up Area (Sq.mt.)	Deductions (Area in Sq.mt.)	Proposed FAR Area (Sq.mt.)	Total FAR Area (Sq.mt.)	Total Consumed Additional FAR Area (Sq.mt.)	Trmt (No.)
A (RESIDENTIAL)	1	258.66	90.15	168.51	168.51	168.51	01
Grand Total :	1	258.66	90.15	168.51	168.51	168.51	01

Building :A (RESIDENTIAL)

Floor Name	Total Built Up Area (Sq.mt.)	Deductions (Area in Sq.mt.)		Proposed FAR Area (Sq.mt.)	Total FAR Area (Sq.mt.)	Total Consumed Additional FAR Area (Sq.mt.)	Trmt (No.)
		Parking	Resi.				
Ground Floor	129.33	0.00	129.33	129.33	129.33	129.33	01
First Floor	129.33	90.15	39.18	39.18	39.18	39.18	00
Terrace Floor	0.00	0.00	0.00	0.00	0.00	0.00	00
Total :	258.66	90.15	168.51	168.51	168.51	168.51	01
Total Number of Same Buildings :	1						
Total :	258.66	90.15	168.51	168.51	168.51	168.51	01

SCHEDULE OF DOOR:

BUILDING NAME	NAME	LENGTH	HEIGHT	NOS
A (RESIDENTIAL)	D	0.84	2.10	01
A (RESIDENTIAL)	D	0.91	2.10	09
A (RESIDENTIAL)	D2	0.91	2.10	01

SCHEDULE OF WINDOW/VENTILATION:

BUILDING NAME	NAME	LENGTH	HEIGHT	NOS
A (RESIDENTIAL)	V	0.75	1.20	01
A (RESIDENTIAL)	W	1.50	1.20	14

UnitBUA Table for Building :A (RESIDENTIAL)

FLOOR	Name	UnitBUA Type	UnitBUA Area	Carpet Area	No. of Rooms	No. of Tenement
GROUND FLOOR PLAN	SPLIT A	FLAT	150.66	149.73	9	1
FIRST FLOOR PLAN	SPLIT A	FLAT	0.00	0.00	2	0
Total:	-	-	150.66	149.73	11	1

LTP NAME AND SIGNATURE	STRUCTURAL ENG'S NAME AND SIGNATURE	BUILDER NAME AND SIGNATURE	DIGITAL SIGNATURE
RANJIT KUMAR MNNP/ENG/0001/2016			

COLOR INDEX

PLOT BOUNDARY	Black
ABUTTING ROAD	Red
PROPOSED CONSTRUCTION	Green
COMMON PLOT	Blue
ROAD WIDENING AREA	Yellow
EXISTING (To be retained)	Light Blue
EXISTING (To be demolished)	Light Yellow

Buildingwise Floor FAR Details

Floor Name	Building Name		Total	
	Proposed Built Up Area (Sq.mt.)	Proposed FAR Area (Sq.mt.)	Total Proposed Built Up Area (Sq.mt.)	Total FAR Area (Sq.mt.)
Ground Floor	129.33	129.33	129.33	129.33
First Floor	129.33	39.18	129.33	39.18
Terrace Floor	0.00	0.00	0.00	0.00
Total :	258.66	168.51	258.66	168.51

Building USE/SUBUSE Details

Building Name	Building Use	Building SubUse	Building Structure
A (RESIDENTIAL)	Residential	Bungalow/ Dwelling / Non Apartment	Non-Highrise