

Proposal Basic Information	
Proposal File No.	MNNP/BJP/0293/W07/2022
Owner Name	ARCHANA KUMARI
Khata No	6
Plot No	315
Village Name	Redma
Use	Residential
SubUse	Bungalow/ Dwelling / Non Apartment

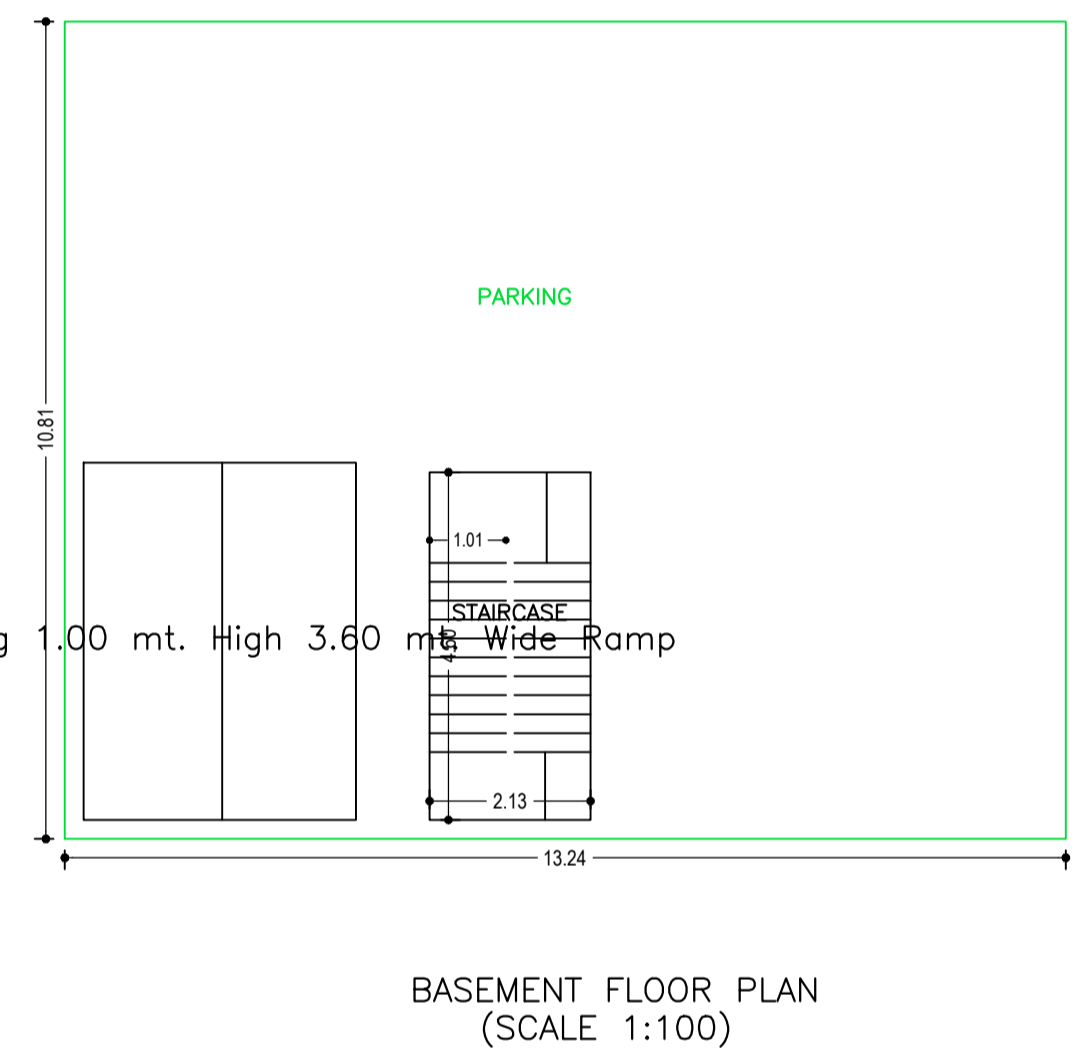

AREA STATEMENT		VERSION NO.:	1.0.64
MEDININAGAR MUNICIPAL CORPORATION		VERSION DATE:	16/10/2020
PROJECT DETAIL:			
Region: JHARKHAND URBAN LOCAL BODIES	Plot Use: Residential		
District: PALAMU	Plot SubUse: Bungalow/ Dwelling / Non Apartment		
Authority: MEDININAGAR MUNICIPAL CORPORATION	PlotNearby/ReligiousStructure: NA		
Inward No: MNNP/BJP/0293/W07/2022	Plot/SubPlot No: 315		
Application Type: General Proposal	North: -		
Project Type: Building Permission	South: -		
Nature of Development: New	East: -		
Location of Development Area: New Area	West: -		
AREA DETAILS:			SQ.MT.
AREA OF PLOT (Minimum)	(A)		241.40
Deduction for NetPlot Area			
Surrender Free of Cost			23.32
Total			23.32
NET AREA OF PLOT(Gross Plot Area - Deduction from Gross Plot area)	(A-Deductions)		218.08
Deduction for Balance Plot Area(from Gross Plot Area)			
Surrender Free of Cost			23.32
Common Plot			15.81
Total			39.12
BALANCE AREA OF PLOT(Net Plot Area - Recreational/Amenity space)	(A-Deductions)		202.28
PLOT AREA FOR COVERAGE(Net Plot Area)	(A-Deductions)		218.08
Plot Area for FAR (Net Plot Area + RoadWidening Area)	(A-Deductions)		241.40
COVERAGE CHECK			
Permissible Coverage area (70.00 %)			152.66
Proposed Coverage Area (65.63 %)			143.12
Total Prop. Coverage Area (65.63 %)			143.12
Balance coverage area (4.37 %)			9.54
FAR CHECK			
Perm. FAR Area (1.20)			289.68
Total Perm. FAR area			289.68
Residential FAR			143.12
Proposed FAR Area			152.92
Total Proposed FAR Area			152.92
Consumed FAR (Factor)			0.63
Balance FAR Area			136.76
BUILT UP AREA CHECK			
Total Proposed BuiltUp Area			286.24
ARCHITECT (Regd)		PANKAJ KUMAR SINGH	
ENGINEER (Regd)			
SUPERVISOR (Regd)			
OWNER (Regd)		ARCHANA KUMARI	
DEVELOPMENT AUTHORITY		LOCAL BODY	

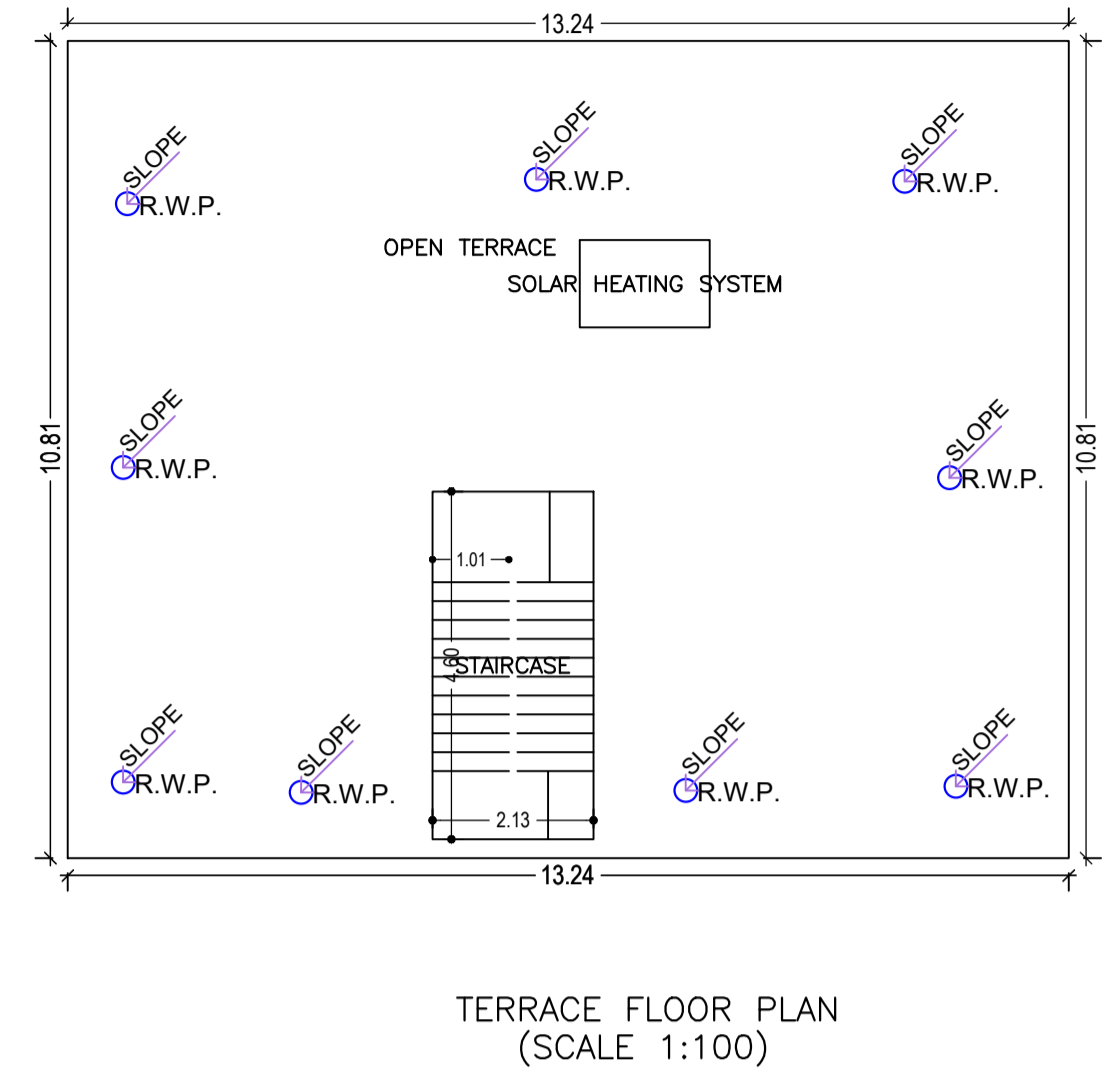
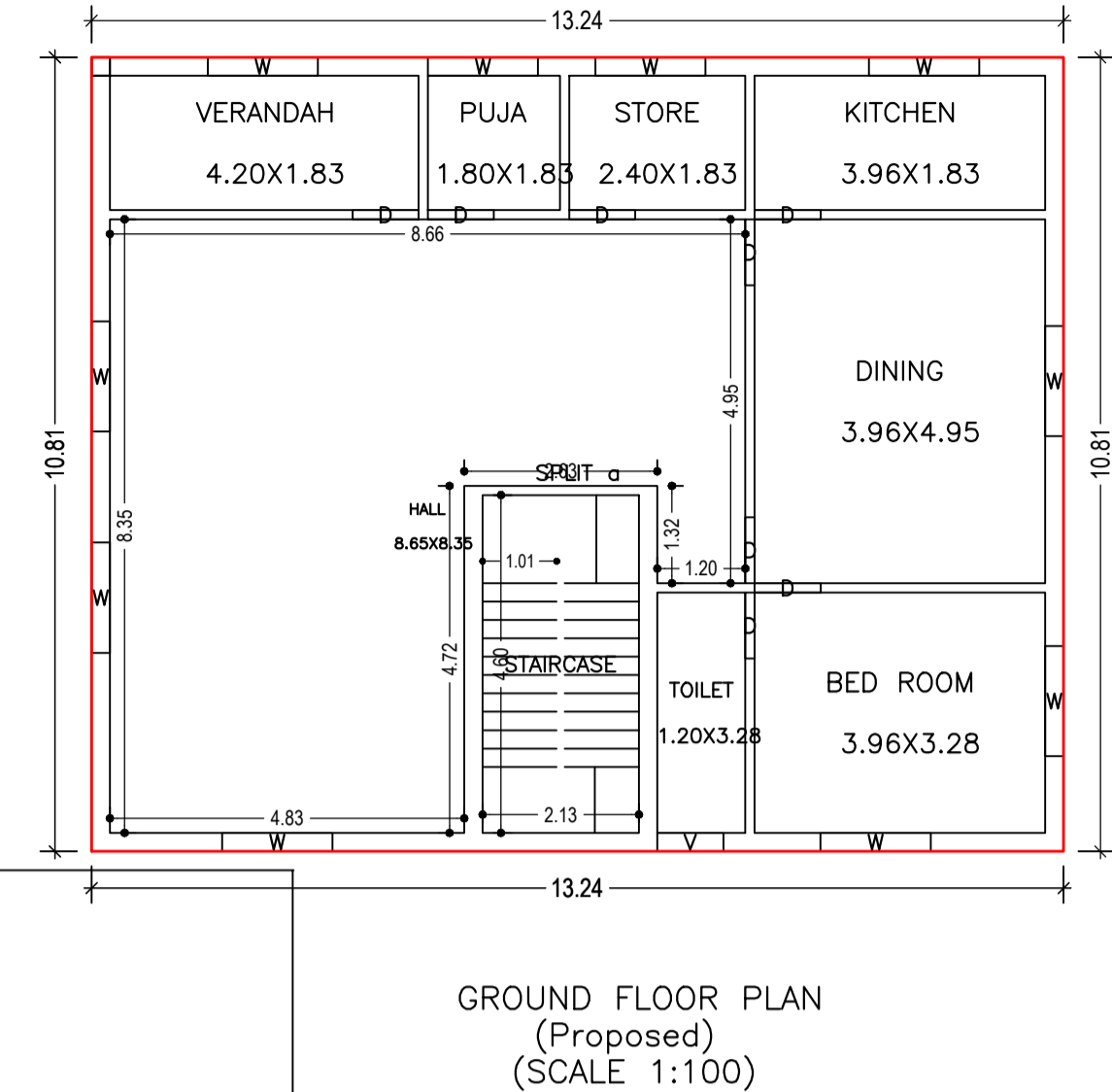
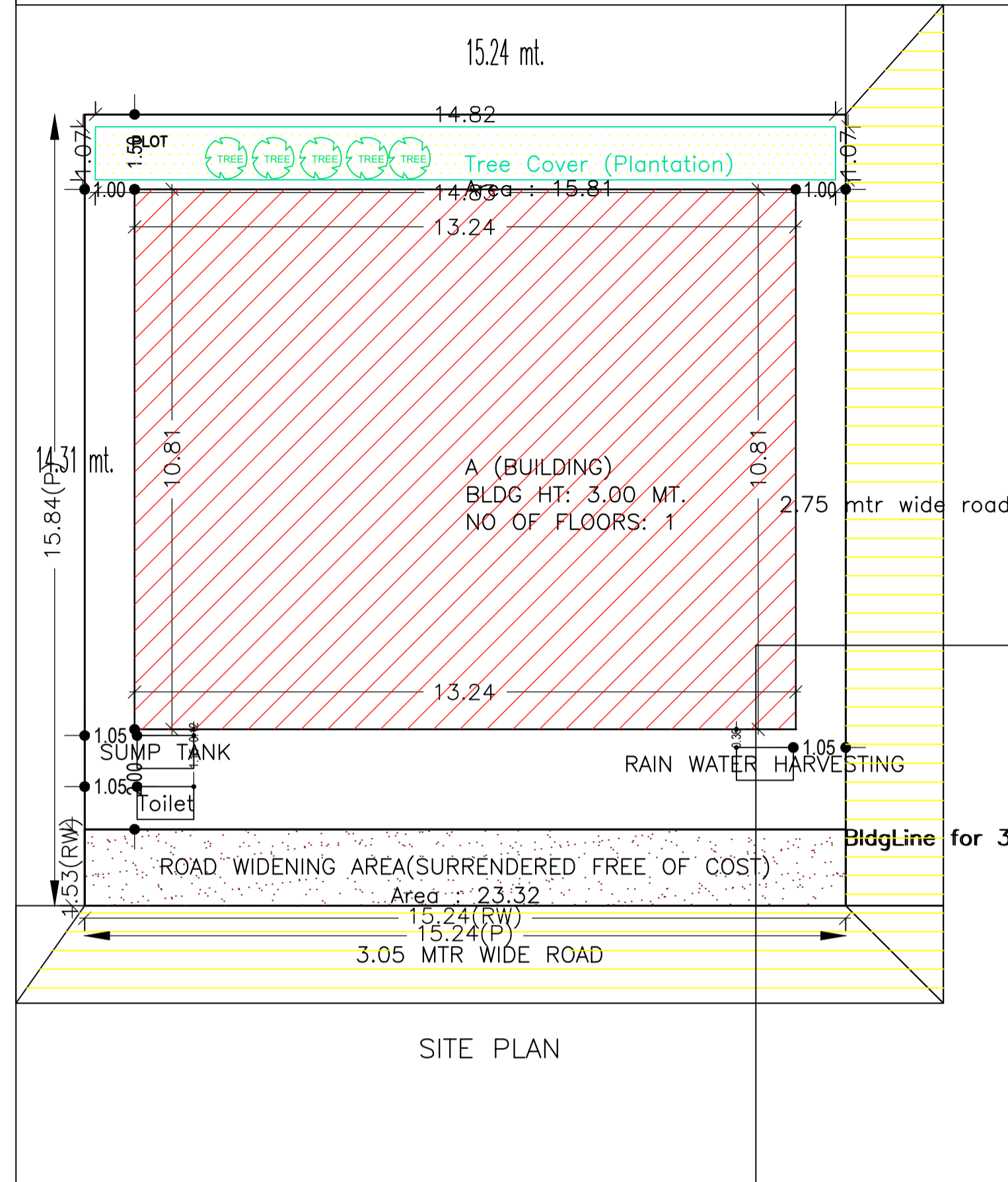
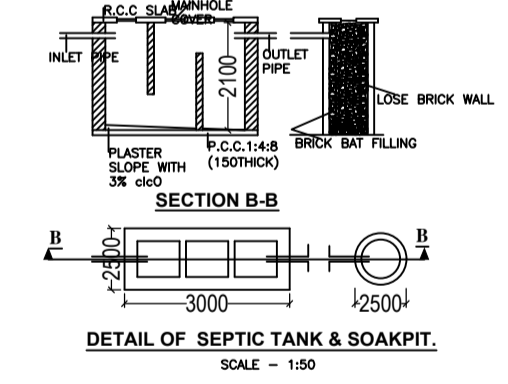
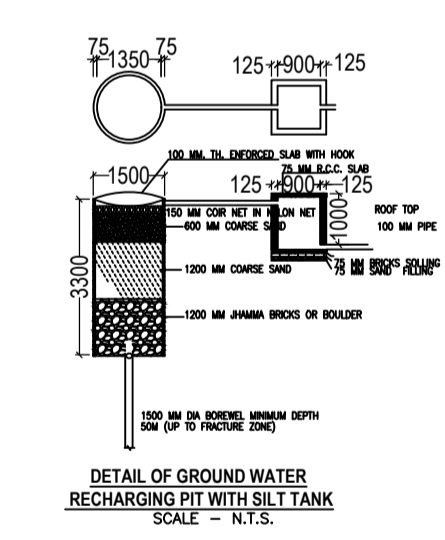
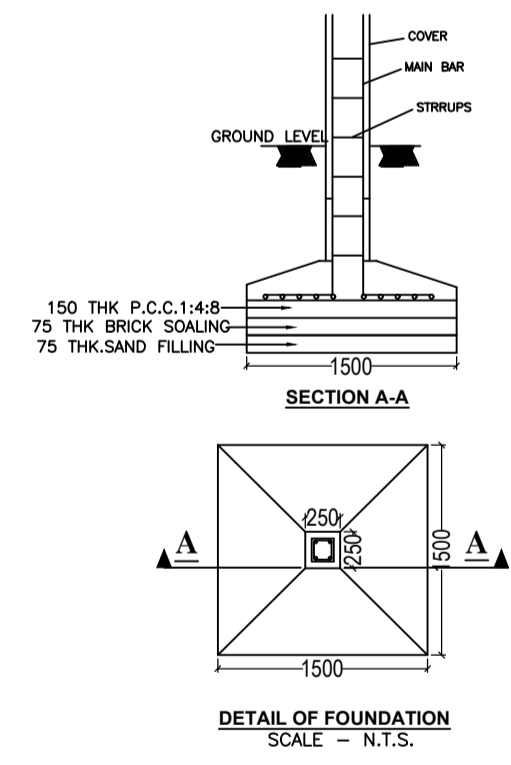
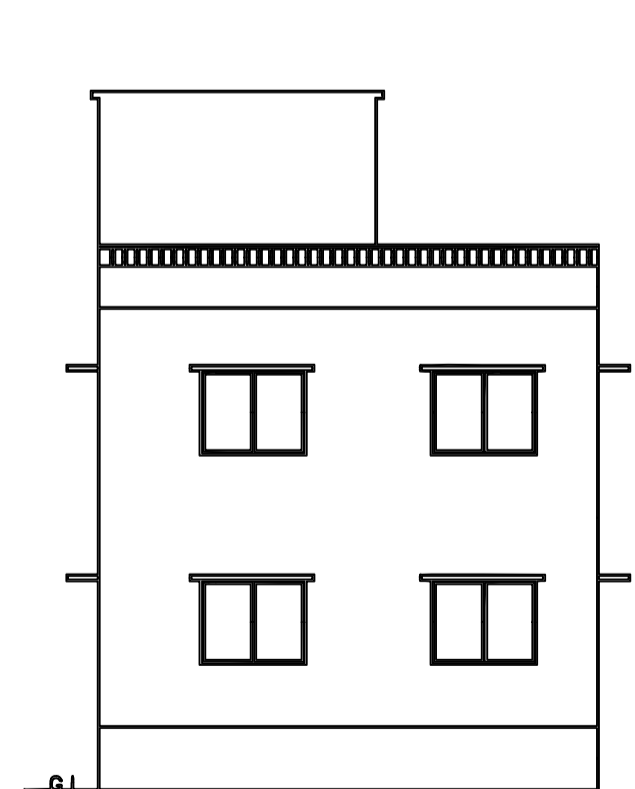
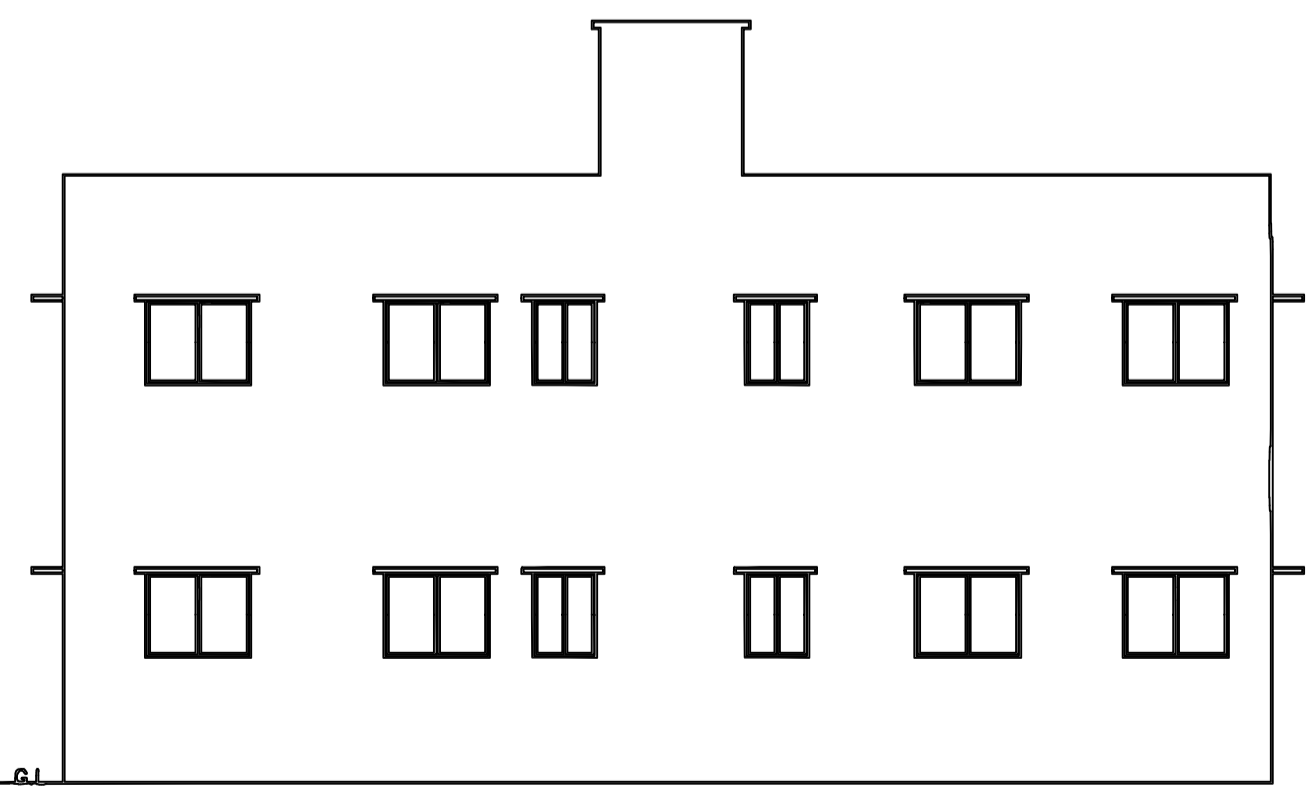
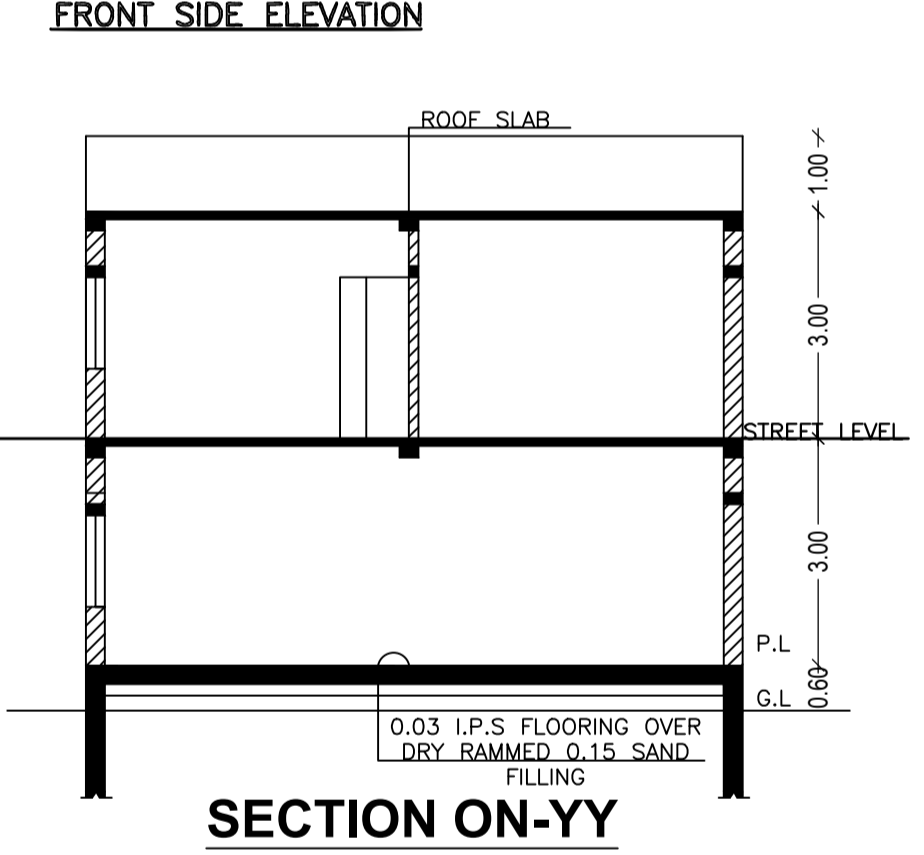
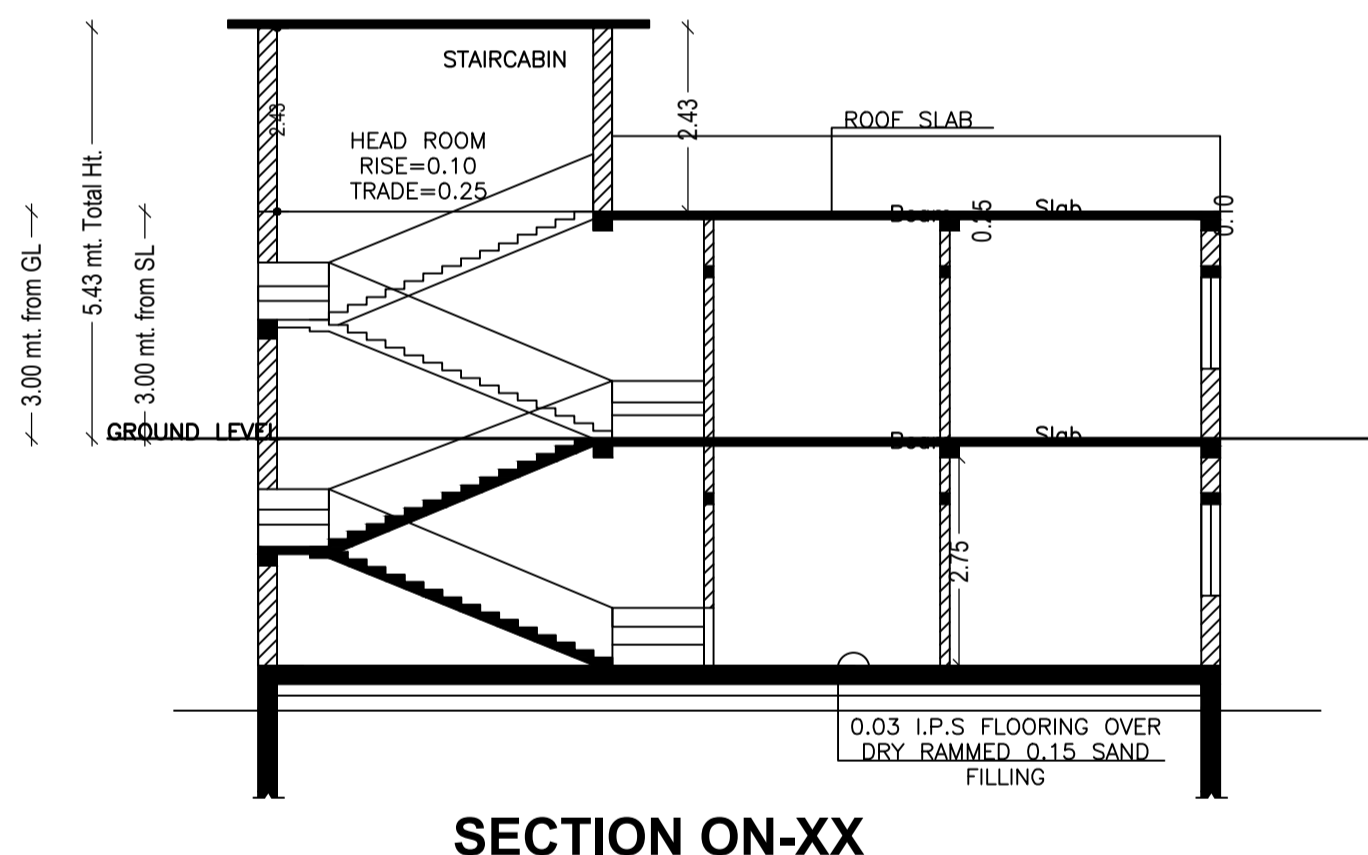

COLOR INDEX	
PLOT BOUNDARY	Black
ABUTTING ROAD	Red
PROPOSED CONSTRUCTION	Green
COMMON PLOT	Yellow
ROAD WIDENING AREA	Blue
EXISTING (To be retained)	Orange
EXISTING (To be demolished)	White

Floor Name	Building Name A (BUILDING)		Total	
	Proposed Built Up Area (Sq.mt.)	Proposed FAR Area (Sq.mt.)	Total Proposed Built Up Area (Sq.mt.)	Total FAR Area (Sq.mt.)
Basement Floor	143.12	9.80	143.12	9.80
Ground Floor	143.12	143.12	143.12	143.12
Terrace Floor	0.00	0.00	0.00	0.00
Total:	286.24	152.92	286.24	152.92

Building Name	Building Use	Building SubUse	Building Structure
A (BUILDING)	Residential	Bungalow/ Dwelling / Non Apartment	Non-Highrise

FAR & Tenement Details (Table 4c-1)								
Building	No. of Same Bldg	Total Built Up Area (Sq.mt.)	Deductions (Area in Sq.mt.)	Proposed FAR Area (Sq.mt.)	Add Area In FAR (Sq.mt.)	Total FAR Area (Sq.mt.)	Total Consumed Additional FAR Area (Sq.mt.)	Tnmt (No.)
A (BUILDING)	1	286.24	116.32	143.12	9.80	152.92	152.92	01
Grand Total:	1	286.24	116.32	143.12	9.80	152.92	152.92	01

SCHEDULE OF DOOR:

BUILDING NAME	NAME	LENGTH	HEIGHT	NOS
A (BUILDING)	D	0.90	2.10	08

SCHEDULE OF WINDOW/VENTILATION:

BUILDING NAME	NAME	LENGTH	HEIGHT	NOS
A (BUILDING)	V	0.90	0.60	01
A (BUILDING)	W	1.50	1.20	10

UnitBUA Table for Building :A (BUILDING)

FLOOR	Name	UnitBUA Type	UnitBUA Area	Carpet Area	No. of Rooms	No. of Tenement
GROUND FLOOR PLAN	SPLIT a	FLAT	132.79	132.73	8	1
Total:	-	-	132.79	132.73	8	1

Building :A (BUILDING)

Floor Name	Total Built Up Area (Sq.mt.)	Deductions (Area in Sq.mt.)	Proposed FAR Area (Sq.mt.)	Add Area In FAR (Sq.mt.)	Total FAR Area (Sq.mt.)	Total Consumed Additional FAR Area (Sq.mt.)	Tnmt (No.)
Basement Floor	143.12	116.32	0.00	9.80	9.80	9.80	00
Ground Floor	143.12	0.00	143.12	0.00	143.12	143.12	01
Terrace Floor	0.00	0.00	0.00	0.00	0.00	0.00	00
Total:	286.24	116.32	143.12	9.80	152.92	152.92	01
Total Number of Same Buildings	1						
Total:	286.24	116.32	143.12	9.80	152.92	152.92	01

LTP NAME AND SIGNATURE	STRUCTURAL ENG'S NAME AND SIGNATURE	BUILDER NAME AND SIGNATURE	DIGITAL SIGNATURE
PANKAJ KUMAR SINGH MNNP/ENG/0006/2019			