

Proposal Basic Information	
Proposal File No.	MNNP/BP/0252/W18/2022
Owner Name	Shalini Kumari
Khata No	21
Plot No	1908
Village Name	Redma
Use	Residential
SubUse	Bungalow/ Dwelling / Non Apartment

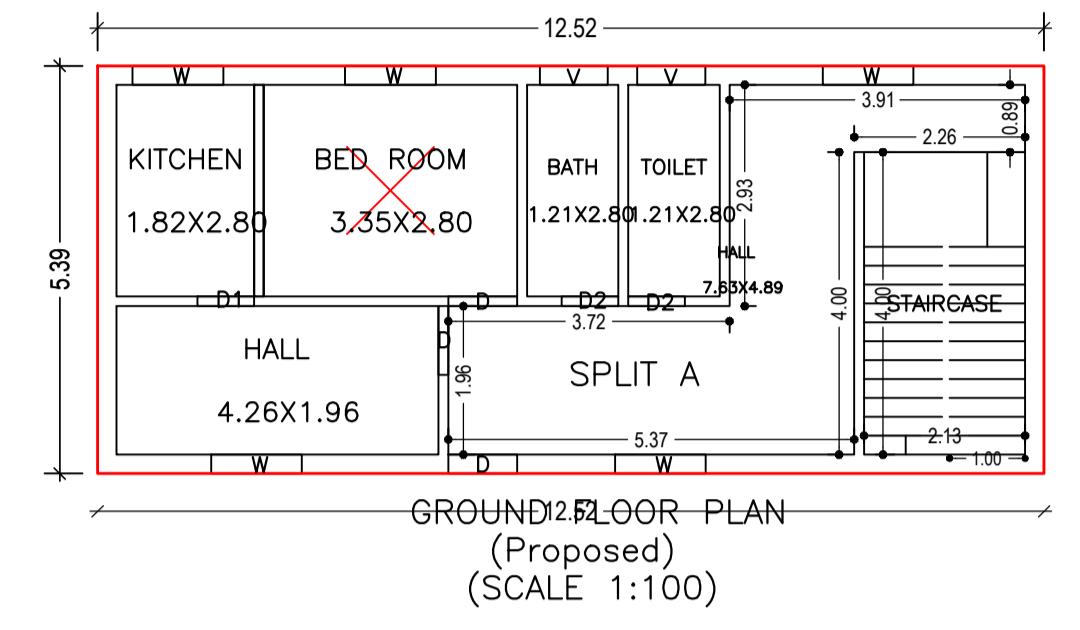

SITE PLAN

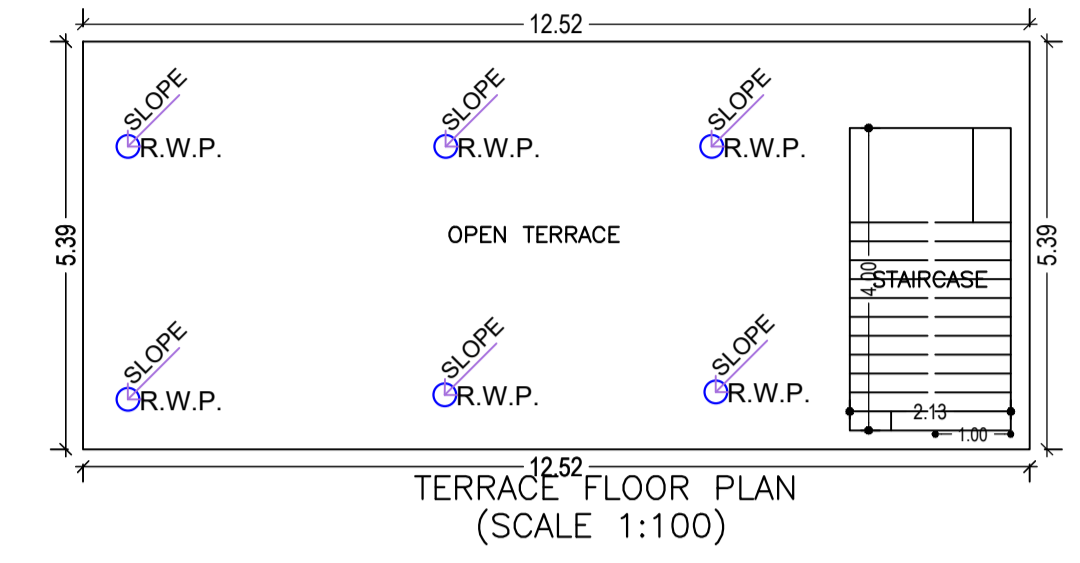
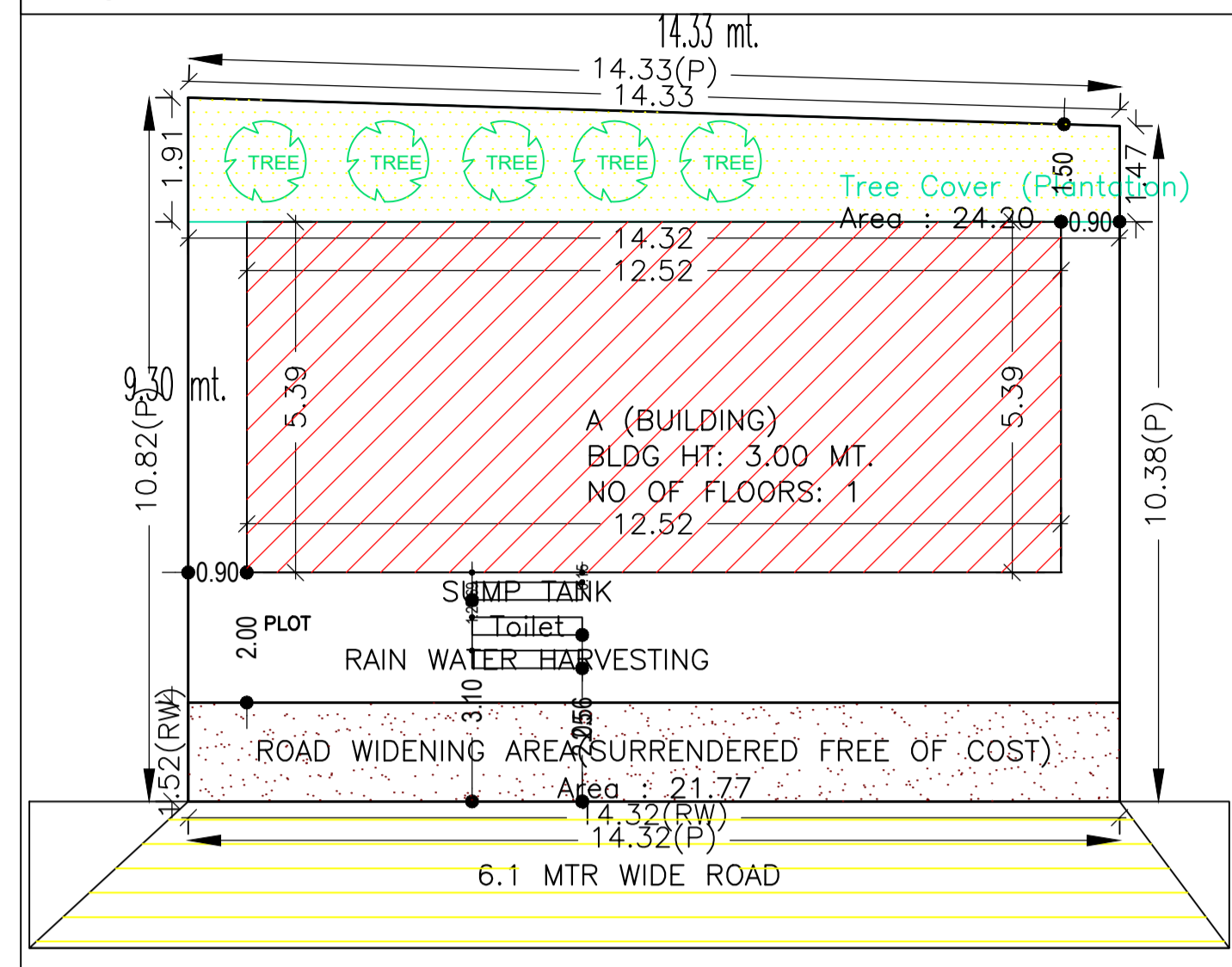
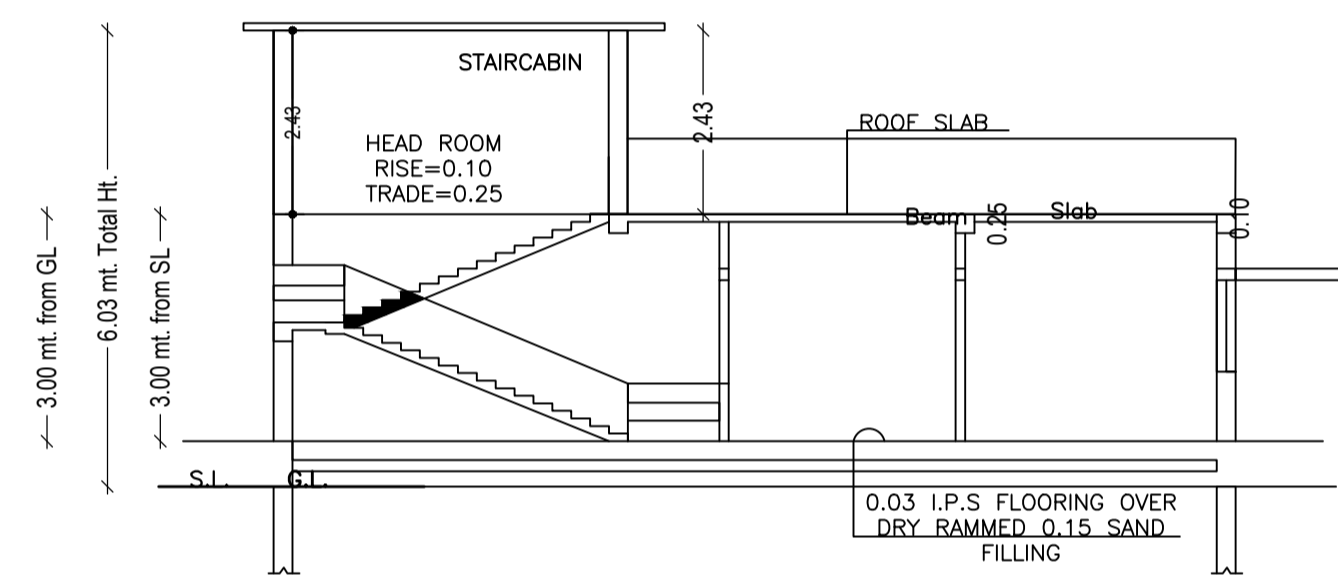

SECTION ON-XX

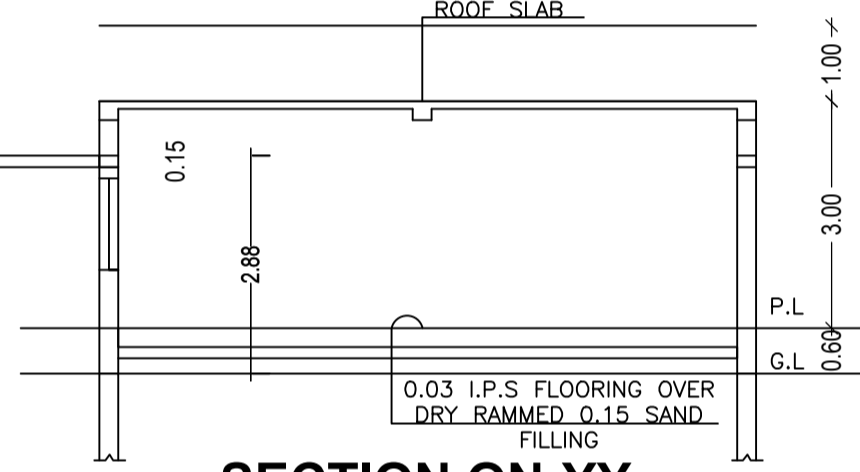

SECTION ON-YY

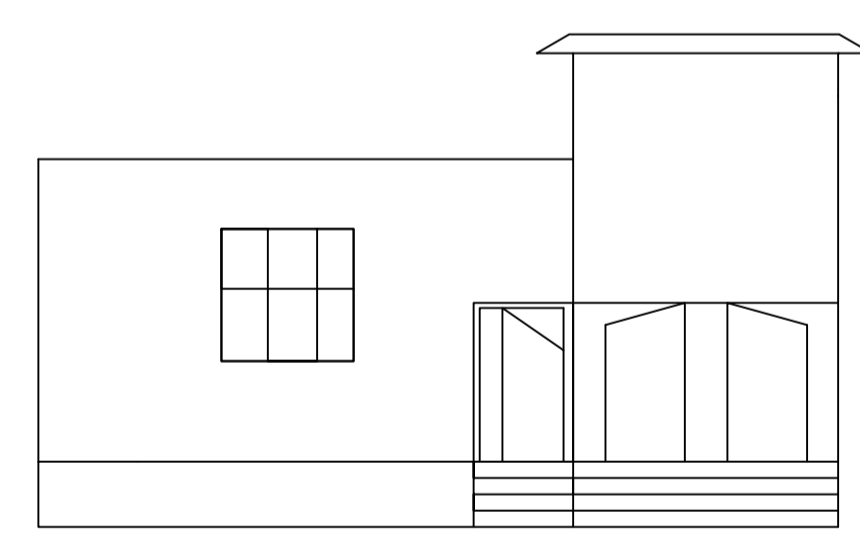

FRONT ELEVATION

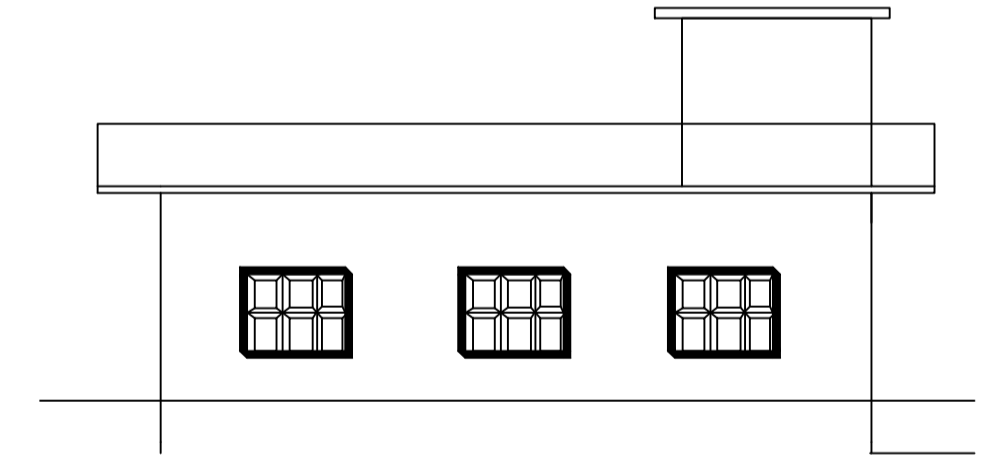

SCHEDULE OF DOOR:

BUILDING NAME	NAME	LENGTH	HEIGHT	NOS
A (BUILDING)	D1	0.75	2.10	01
A (BUILDING)	D2	0.75	2.10	02
A (BUILDING)	D	0.91	2.10	03

SCHEDULE OF WINDOW/VENTILATION:

BUILDING NAME	NAME	LENGTH	HEIGHT	NOS
A (BUILDING)	V	0.90	0.60	02
A (BUILDING)	W	1.20	1.20	05

UnitBUA Table for Building :A (BUILDING)

FLOOR	Name	UnitBUA Type	UnitBUA Area	Carpet Area	No. of Rooms	No. of Tenement
GROUND FLOOR PLAN	SPLIT A	FLAT	56.85	56.48	6	1
Total:	-	-	56.85	56.48	6	1

FAR & Tenement Details (Table 4c-1)

Building	No. of Same Bldg	Total Built Up Area (Sq.mt.)	Proposed FAR Area (Sq.mt.)	Total FAR Area (Sq.mt.)	Total Consumed Additional FAR Area (Sq.mt.)	Tnmt (No.)
A (BUILDING)	1	67.51	67.51	67.51	67.51	01
Grand Total:	1	67.51	67.51	67.51	67.51	01

Building :A (BUILDING)

Floor Name	Total Built Up Area (Sq.mt.)	Proposed FAR Area (Sq.mt.)		Total Consumed Additional FAR Area (Sq.mt.)	Tnmt (No.)
		Resi.	Total FAR Area (Sq.mt.)		
Ground Floor	67.51	67.51	67.51	67.51	01
Terrace Floor	0.00	0.00	0.00	0.00	00
Total :	67.51	67.51	67.51	67.51	01
Total Number of Same Buildings :	1				
Total :	67.51	67.51	67.51	67.51	01

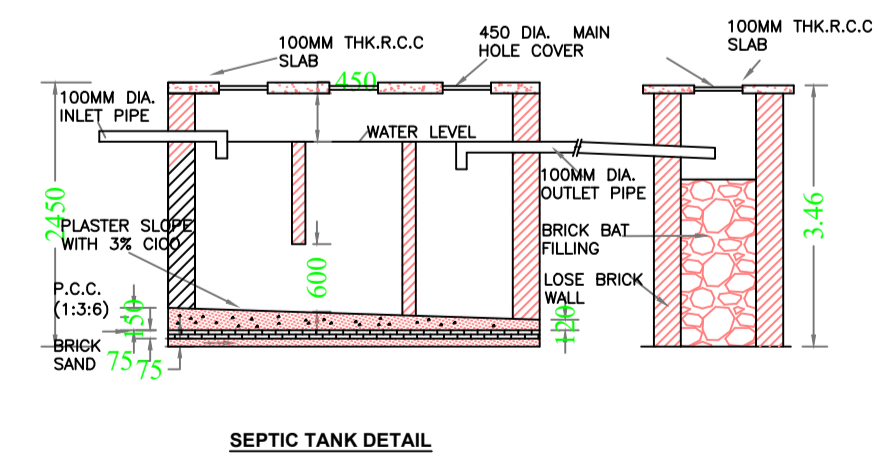
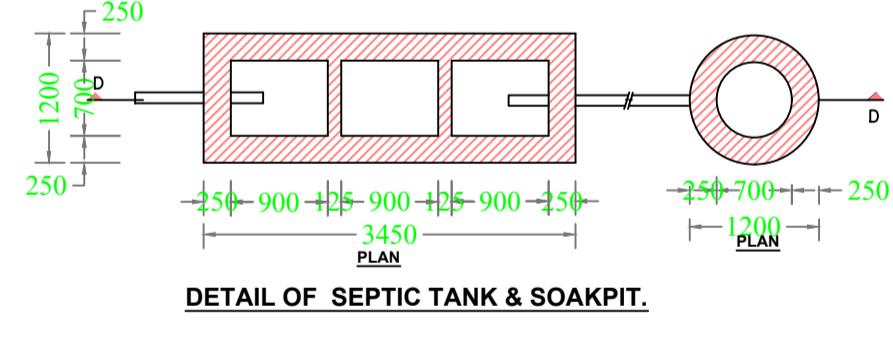
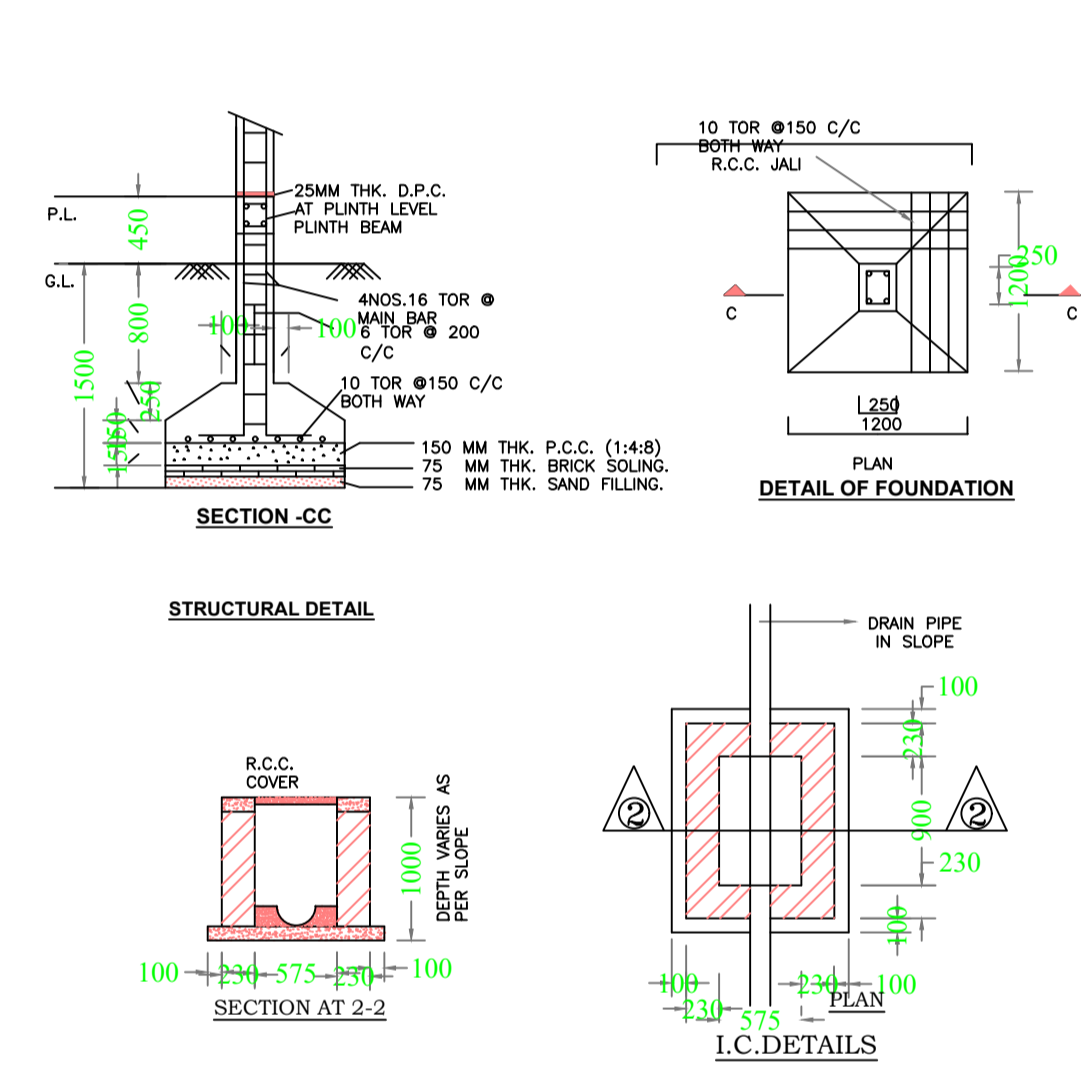

AREA STATEMENT		VERSION NO. : 1.0.64
MEDINAGAR MUNICIPAL CORPORATION		VERSION DATE: 16/10/2020
PROJECT DETAIL:		
Region: JHARKHAND URBAN LOCAL BODIES	Plot Use: Residential	
District: PALAMU	Plot SubUse: Bungalow/ Dwelling / Non Apartment	
Authority: MEDINAGAR MUNICIPAL CORPORATION	PlotNearby/Religious/Structure: NA	
Inward No: MNNP/BP/0252/W18/2022	Plot/SubPlot No: 1908	
Application Type: General Proposal	North: -	
Project Type: Building Permission	South: -	
Nature of Development: New	East: -	
Location of Development Area: Old Area	West: -	
AREA DETAILS:		
AREA OF PLOT (Minimum)	(A)	151.30 SQ.MT.
Deduction for NetPlot Area		
Surrender Free of Cost		21.77
Total		21.77
NET AREA OF PLOT(Gross Plot Area - Deduction from Gross Plot area)	(A-Deductions)	129.53
Deduction for Balance Plot Area(from Gross Plot Area)		
Surrender Free of Cost		21.77
Common Plot		24.20
Total		45.97
BALANCE AREA OF PLOT (Net Plot Area - Recreational/Amenity space)	(A-Deductions)	105.33
PLOT AREA FOR COVERAGE(Net Plot Area)	(A-Deductions)	129.53
Plot Area for FAR (Net Plot Area + RoadWidening Area)	(A-Deductions)	151.30
COVERAGE CHECK		
Permissible Coverage area (70.00 %)		90.67
Proposed Coverage Area (52.12 %)		67.51
Total Prop. Coverage Area (52.12 %)		67.51
Balance coverage area (17.88 %)		23.16
FAR CHECK		
Perm. FAR Area (2.50)		378.25
Total Perm. FAR area		378.25
Residential FAR		67.51
Proposed FAR Area		67.51
Total Proposed FAR Area		67.51
Consumed FAR (Factor)		0.45
Balance FAR Area		310.74
BUILT UP AREA CHECK		
Total Proposed BuiltUp Area		67.51
ARCHITECT (Regd)	RANJIT KUMAR	
ENGINEER (Regd)		
SUPERVISOR (Regd)		
OWNER (Regd)	Shalini Kumari	
DEVELOPMENT AUTHORITY		LOCAL BODY

COLOR INDEX	
PLOT BOUNDARY	Black
ABUTTING ROAD	Green
PROPOSED CONSTRUCTION	Red
COMMON PLOT	Yellow
ROAD WIDENING AREA	Blue
EXISTING (To be retained)	Grey
EXISTING (To be demolished)	White

Buildingwise Floor FAR Details

Floor Name	Building Name A (BUILDING)		Total	
	Proposed Built Up Area (Sq.mt.)	Proposed FAR Area (Sq.mt.)	Total Proposed Built Up Area (Sq.mt.)	Total FAR Area (Sq.mt.)
Ground Floor	67.51	67.51	67.51	67.51
Terrace Floor	0.00	0.00	0.00	0.00
Total :	67.51	67.51	67.51	67.51

Building USE/SUBUSE Details

Building Name	Building Use	Building SubUse	Building Structure
A (BUILDING)	Residential	Bungalow/ Dwelling / Non Apartment	Non-Highrise

LTP NAME AND SIGNATURE	STRUCTURAL ENG'S NAME AND SIGNATURE	BUILDER NAME AND SIGNATURE	DIGITAL SIGNATURE
RANJIT KUMAR MNNP/ENG/0001/2016			