

SITE PLAN

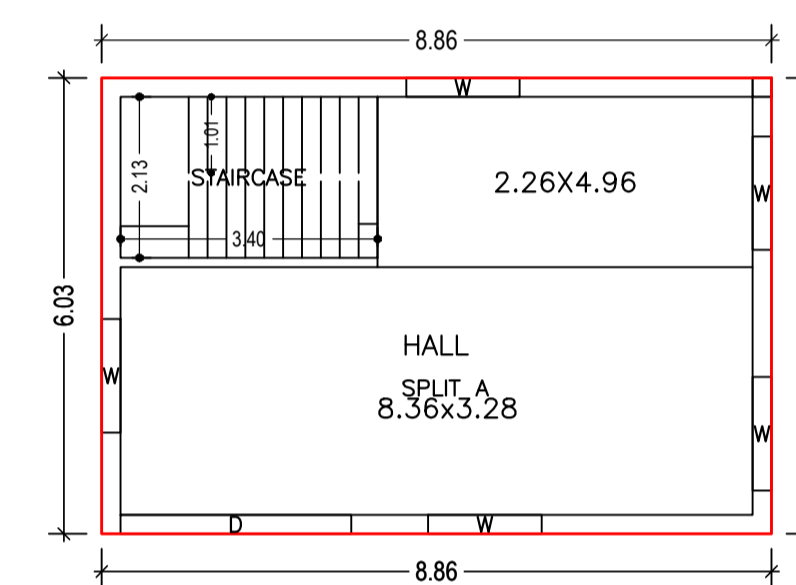

GROUND FLOOR PLAN (Proposed) (SCALE 1:100)

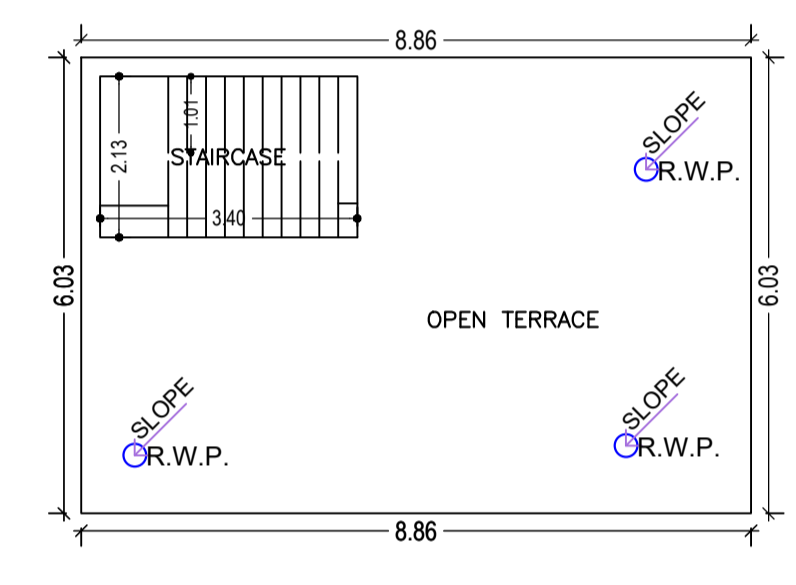

TERRACE FLOOR PLAN (SCALE 1:100)

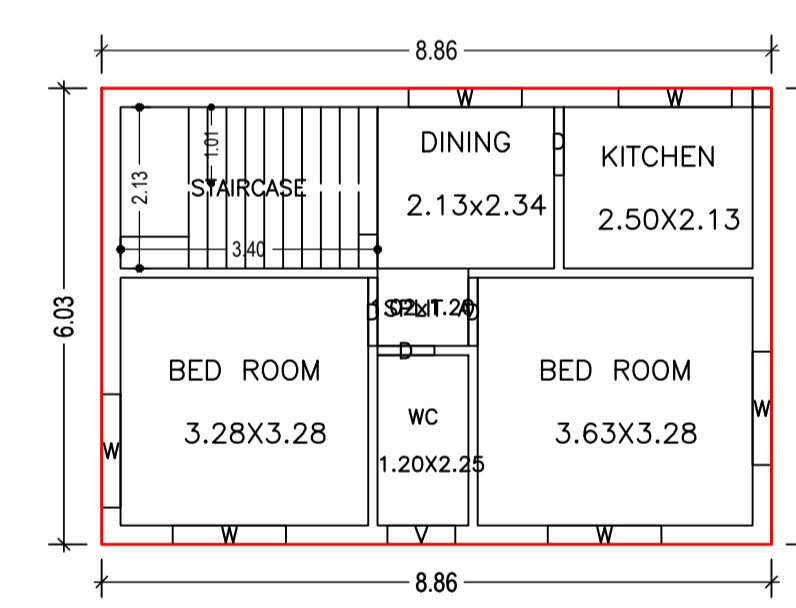

FIRST FLOOR PLAN (Proposed) (SCALE 1:100)

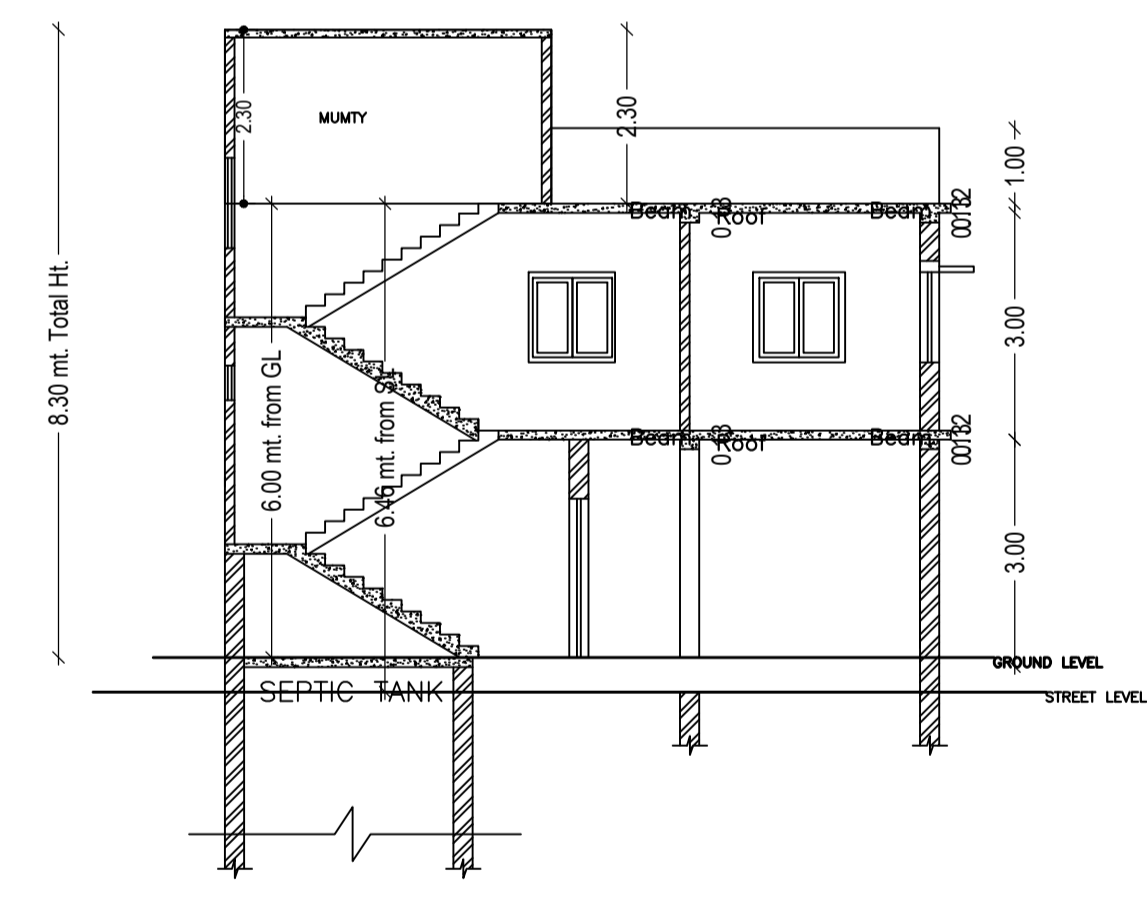

SECTION DETAILS (SCALE 1:100)

Building :A (BUILDING)

Floor Name	Total Built Up Area (Sq.mt.)	Proposed FAR Area (Sq.mt.) Resi.	Total FAR Area (Sq.mt.)	Total Consumed Additional FAR Area (Sq.mt.)	Tnmt (No.)
Ground Floor	53.43	53.43	53.43	53.43	01
First Floor	53.43	53.43	53.43	53.43	00
Terrace Floor	0.00	0.00	0.00	0.00	00
Total :	106.86	106.86	106.86	106.86	01
Total Number of Same Buildings	1				
Total :	106.86	106.86	106.86	106.86	01

SCHEDULE OF DOOR:

BUILDING NAME	NAME	LENGTH	HEIGHT	NOS
A (BUILDING)	D	0.75	2.10	01
A (BUILDING)	D	0.90	2.10	03
A (BUILDING)	D	3.05	2.10	01

SCHEDULE OF WINDOW/VENTILATION:

BUILDING NAME	NAME	LENGTH	HEIGHT	NOS
A (BUILDING)	V	0.90	0.60	01
A (BUILDING)	W	1.50	1.20	11

UnitBUA Table for Building :A (BUILDING)

FLOOR	Name	UnitBUA Type	UnitBUA Area	Carpet Area	No. of Rooms	No. of Tenement
FIRST FLOOR PLAN	SPLIT A	FLAT	0.00	0.00	5	0
GROUND FLOOR PLAN	SPLIT A	FLAT	89.48	89.35	1	1
Total:	-	-	89.48	89.35	6	1

FAR & Tenement Details (Table 4c-1)

Building	No. of Same Bldg	Total Built Up Area (Sq.mt.)	Proposed FAR Area (Sq.mt.) Resi.	Total FAR Area (Sq.mt.)	Total Consumed Additional FAR Area (Sq.mt.)	Tnmt (No.)
A (BUILDING)	1	106.86	106.86	106.86	106.86	01
Grand Total :	1	106.86	106.86	106.86	106.86	01

Proposal Basic Information

Proposal File No.	MNNP/BP/0263/W09/2022
Owner Name	AWADHESH KUMAR SINGH
Khata No	62
Plot No	580
Village Name	Sudna
Use	Residential
SubUse	Bungalow/ Dwelling / Non Apartment

AREA STATEMENT

AREA DETAILS:		SQ.MT.
AREA OF PLOT (Minimum)	(A)	112.15
Deduction for NetPlot Area		
Surrender Free of Cost		6.62
Total		6.62
NET AREA OF PLOT(Gross Plot Area - Deduction from Gross Plot area)	(A-Deductions)	105.53
Deduction for Balance Plot Area(from Gross Plot Area)		
Surrender Free of Cost		6.62
Common Plot		15.19
Total		21.81
BALANCE AREA OF PLOT(Net Plot Area - Recreational/Amenity space)	(A-Deductions)	90.34
PLOT AREA FOR COVERAGE(Net Plot Area)	(A-Deductions)	105.53
Plot Area for FAR (Net Plot Area + Road/Widening Area)	(A-Deductions)	112.15
COVERAGE CHECK		
Permissible Coverage area ( 70.00 % )		73.87
Proposed Coverage Area ( 50.63 % )		53.43
Total Prop. Coverage Area ( 50.63 % )		53.43
Balance coverage area ( 19.37 % )		20.44
FAR CHECK		
Perm. FAR Area ( 1.80 )		201.87
Total Perm. FAR area		201.87
Residential FAR		106.86
Proposed FAR Area		106.86
Total Proposed FAR Area		106.86
Consumed FAR (Factor)		0.95
Balance FAR Area		95.02
BUILT UP AREA CHECK		
Total Proposed BuiltUp Area		106.86
ARCHITECT (Regd)	CHANDRA SHEKHAR THAKUR	
ENGINEER (Regd)		
SUPERVISOR (Regd)		
OWNER (Regd)	AWADHESH KUMAR SINGH	
DEVELOPMENT AUTHORITY	LOCAL BODY	

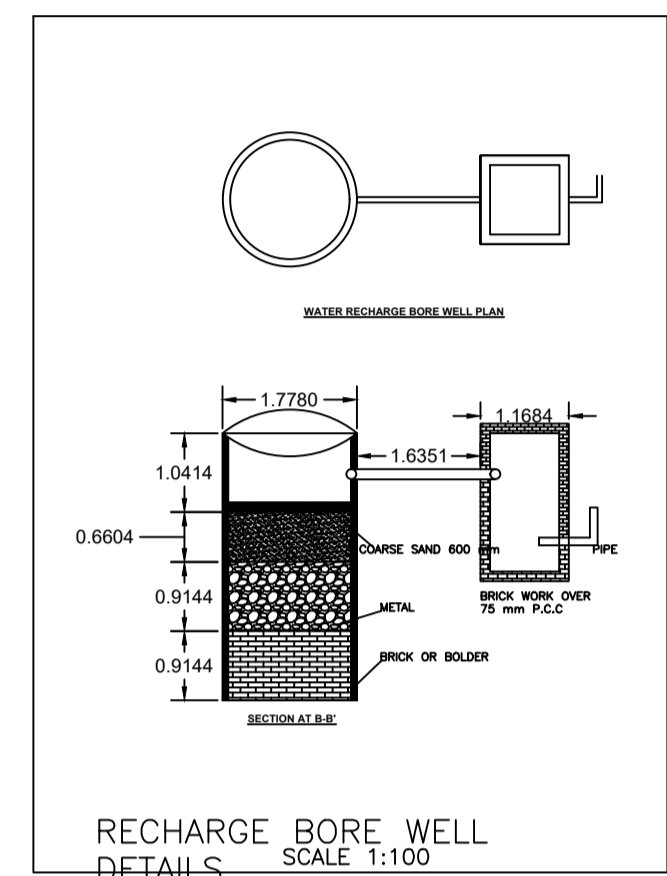

RECHARGE BORE WELL DETAILS (SCALE 1:100)

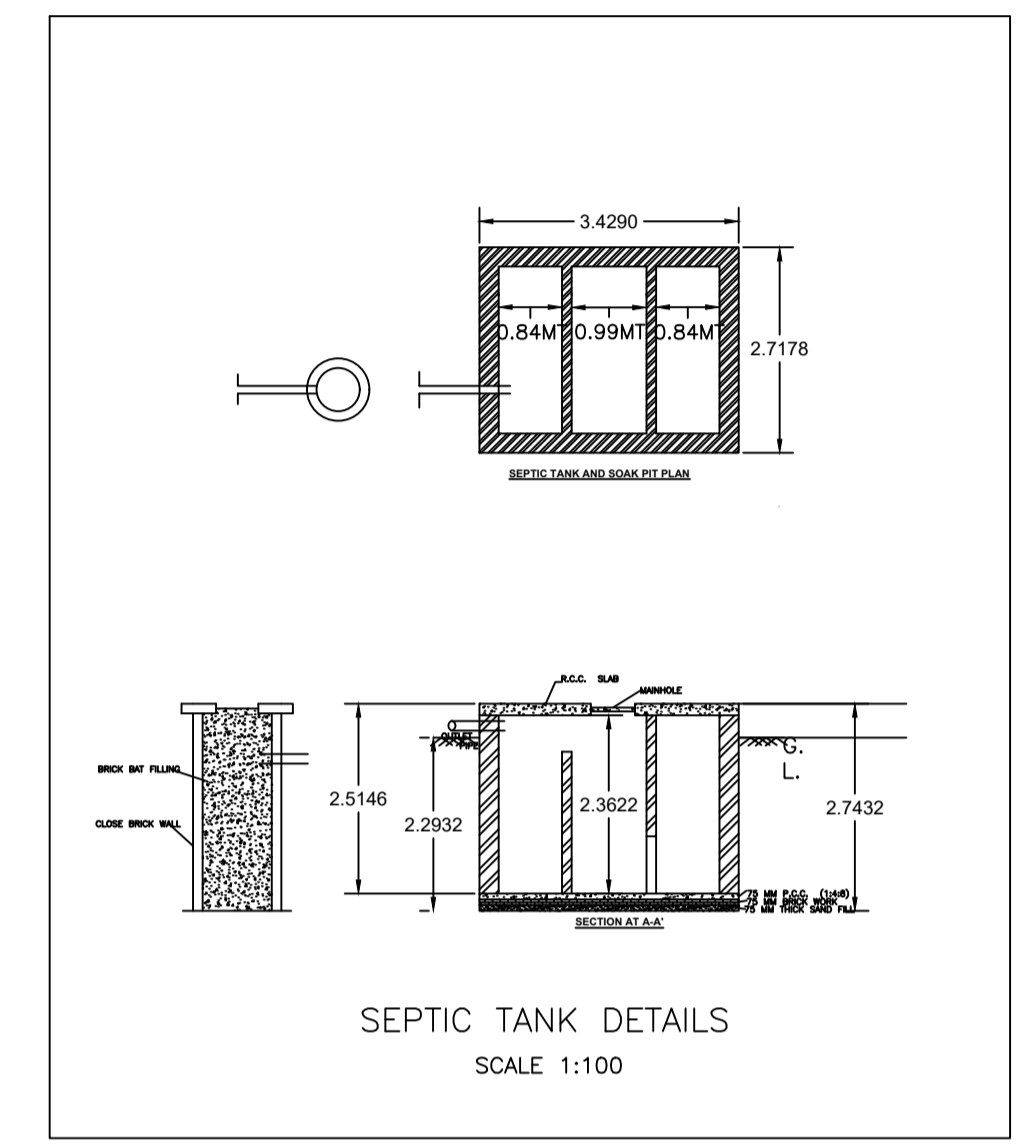

SEPTIC TANK DETAILS (SCALE 1:100)



FRONT ELEVATION (SCALE 1:100)

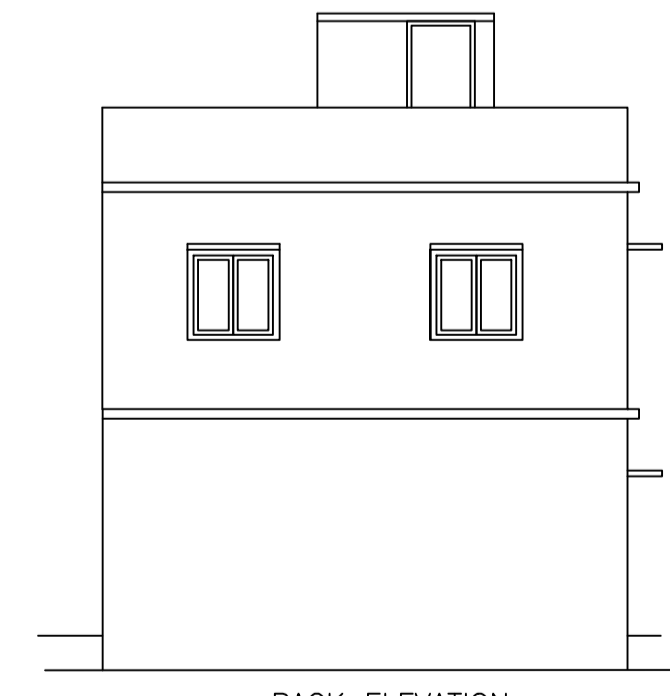

BACK ELEVATION (SCALE 1:100)

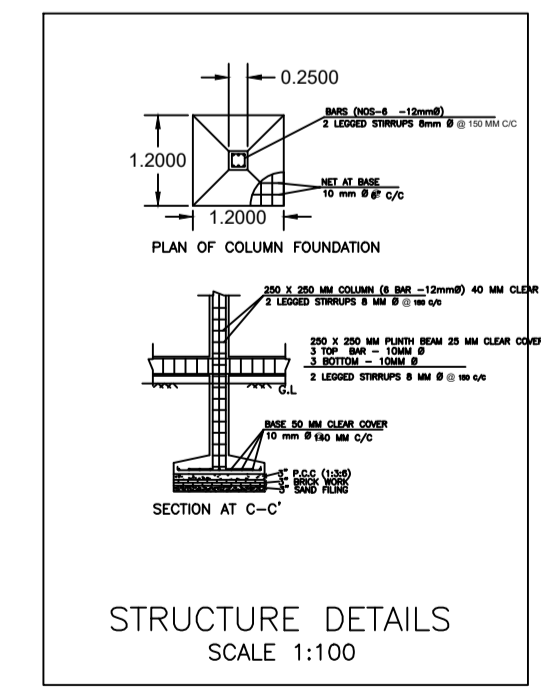

STRUCTURE DETAILS (SCALE 1:100)

COLOR INDEX

PLOT BOUNDARY	Black
ABUTTING ROAD	Green
PROPOSED CONSTRUCTION	Red
COMMON PLOT	Yellow
ROAD WIDENING AREA	Blue
EXISTING (To be retained)	Blue
EXISTING (To be demolished)	Yellow

Buildingwise Floor FAR Details

Floor Name	Building Name		Total	
	Proposed Built Up Area (Sq.mt.)	Proposed FAR Area (Sq.mt.)	Total Proposed Built Up Area (Sq.mt.)	Total FAR Area (Sq.mt.)
Ground Floor	53.43	53.43	53.43	53.43
First Floor	53.43	53.43	53.43	53.43
Terrace Floor	0.00	0.00	0.00	0.00
Total :	106.86	106.86	106.86	106.86

Building USE/SUBUSE Details

Building Name	Building Use	Building SubUse	Building Structure
A (BUILDING)	Residential	Bungalow/ Dwelling / Non Apartment	Non-Highrise

LTP NAME AND SIGNATURE	STRUCTURAL ENG'S NAME AND SIGNATURE	BUILDER NAME AND SIGNATURE	DIGITAL SIGNATURE
CHANDRA SHEKHAR THAKUR MNNP/ENG/0004/2020			