

Proposal Basic Information

Proposal File No.	MNNP/BP/0262/W02/2022
Owner Name	SILA DEVI
Khata No	44
Plot No	285
Village Name	Nimiya
Use	Residential
SubUse	Bungalow/ Dwelling / Non Apartment

AREA STATEMENT MEDINAGAR MUNICIPAL CORPORATION	VERSION No.: 1.0.64 VERSION DATE: 16/10/2020
PROJECT DETAIL:	
Region: JHARKHAND URBAN LOCAL BODIES	Plot Use: Residential
District: PALAMU	Plot SubUse: Bungalow/ Dwelling / Non Apartment
Authority: MEDINAGAR MUNICIPAL CORPORATION	PlotNearbyReligiousStructure: NA
Inward No: MNNP/BP/0262/W02/2022	Plot/SubPlot No: 285
Application Type: General Proposal	North: -
Project Type: Building Permission	South: -
Nature of Development: New	East: -
Location of Development Area: Old Area	West: -
AREA DETAILS:	SQ.MT.
AREA OF PLOT (Minimum)	(A) 151.20
Deduction for NetPlot Area	
Surrender Free of Cost	11.81
Total	11.81
NET AREA OF PLOT(Gross Plot Area - Deduction from Gross Plot area)	(A-Deductions) 139.39
Deduction for Balance Plot Area(from Gross Plot Area)	
Surrender Free of Cost	11.81
Common Plot	7.24
Total	19.05
BALANCE AREA OF PLOT(Net Plot Area - Recreational/Amenity space)	(A-Deductions) 132.15
PLOT AREA FOR COVERAGE(Net Plot Area)	(A-Deductions) 139.39
Plot Area for FAR (Net Plot Area - Road/Widening Area)	(A-Deductions) 151.20
COVERAGE CHECK	
Permissible Coverage area ( 70.00 % )	97.57
Proposed Coverage Area ( 35.64 % )	49.68
Total Prop. Coverage Area ( 35.64 % )	49.68
Balance coverage area ( 34.36 % )	47.89
FAR CHECK	
Perm. FAR Area ( 1.20 )	181.44
Total Perm. FAR area	181.44
Residential FAR	99.36
Proposed FAR Area	99.36
Total Proposed FAR Area	99.36
Consumed FAR (Factor)	0.66
Balance FAR Area	82.08
BUILT UP AREA CHECK	
Total Proposed BuiltUp Area	99.36
ARCHITECT (Regd)	CHANDRA SHEKHAR THAKUR
ENGINEER (Regd)	
SUPERVISOR (Regd)	
OWNER (Regd)	SILA DEVI
DEVELOPMENT AUTHORITY	LOCAL BODY

SCHEDULE OF DOOR:

BUILDING NAME	NAME	LENGTH	HEIGHT	NOS
A (BUILDING)	D1	0.75	2.10	02
A (BUILDING)	D	0.90	2.10	06

SCHEDULE OF WINDOW/VENTILATION:

BUILDING NAME	NAME	LENGTH	HEIGHT	NOS
A (BUILDING)	V	0.90	0.60	02
A (BUILDING)	W	1.20	1.20	12

UnitBUA Table for Building :A (BUILDING)

FLOOR	Name	UnitBUA Type	UnitBUA Area	Carpet Area	No. of Rooms	No. of Tenement
GROUND FLOOR PLAN	SPLIT A	FLAT	81.98	81.86	5	1
FIRST FLOOR PLAN	SPLIT A	FLAT	0.00	0.00	5	0
Total:	-	-	81.98	81.86	10	1

Building :A (BUILDING)

Floor Name	Total Built Up Area (Sq.mt.)	Proposed FAR Area (Sq.mt.) Resi.	Total FAR Area (Sq.mt.)	Total Consumed Additional FAR Area (Sq.mt.)	Tnmt (No.)
Ground Floor	49.68	49.68	49.68	49.68	01
First Floor	49.68	49.68	49.68	49.68	00
Terrace Floor	0.00	0.00	0.00	0.00	00
Total:	99.36	99.36	99.36	99.36	01
Total Number of Same Buildings :	1				
Total :	99.36	99.36	99.36	99.36	01

FAR & Tenement Details (Table 4c-1)

Building	No. of Same Bldg	Total Built Up Area (Sq.mt.)	Proposed FAR Area (Sq.mt.)	Total FAR Area (Sq.mt.)	Total Consumed Additional FAR Area (Sq.mt.)	Tnmt (No.)
			Resi.			
A (BUILDING)	1	99.36	99.36	99.36	99.36	01
Grand Total :	1	99.36	99.36	99.36	99.36	01

COLOR INDEX

PLOT BOUNDARY	Black
ABUTTING ROAD	Red
PROPOSED CONSTRUCTION	Green
COMMON PLOT	Yellow
ROAD WIDENING AREA	Blue
EXISTING (To be retained)	Orange
EXISTING (To be demolished)	Light Blue

Buildingwise Floor FAR Details

Floor Name	Building Name A (BUILDING)		Total	
	Proposed Built Up Area (Sq.mt.)	Proposed FAR Area (Sq.mt.)	Total Proposed Built Up Area (Sq.mt.)	Total FAR Area (Sq.mt.)
Ground Floor	49.68	49.68	49.68	49.68
First Floor	49.68	49.68	49.68	49.68
Terrace Floor	0.00	0.00	0.00	0.00
Total :	99.36	99.36	99.36	99.36

Building USE/SUBUSE Details

Building Name	Building Use	Building SubUse	Building Structure
A (BUILDING)	Residential	Bungalow/ Dwelling / Non Apartment	Non-Highrise

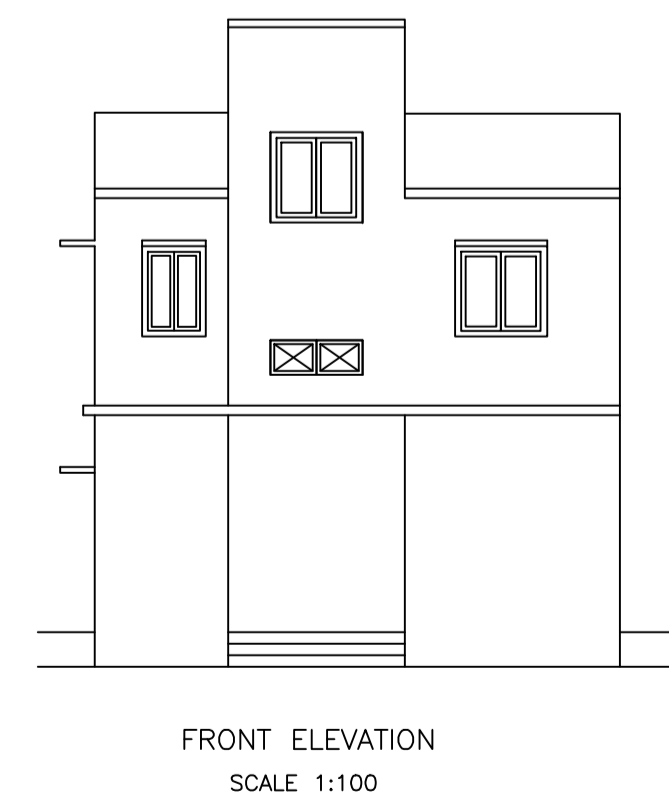
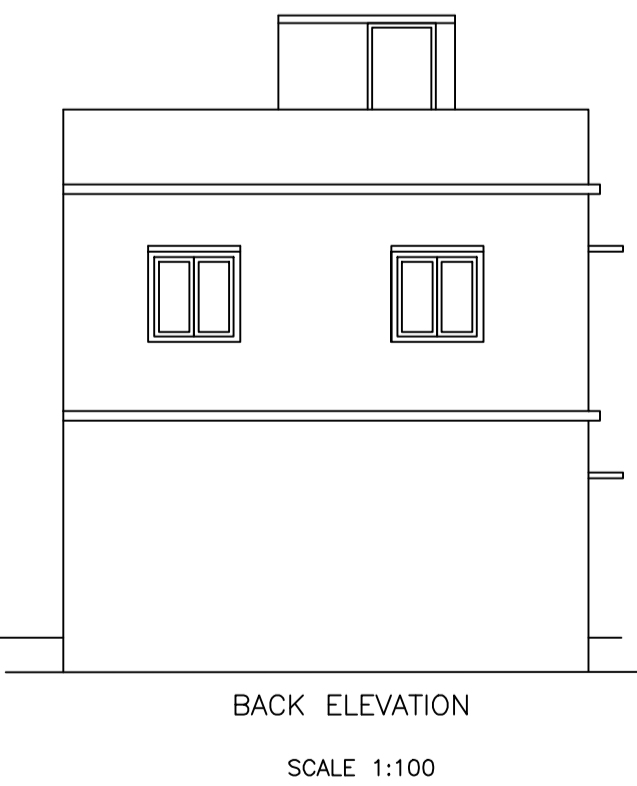
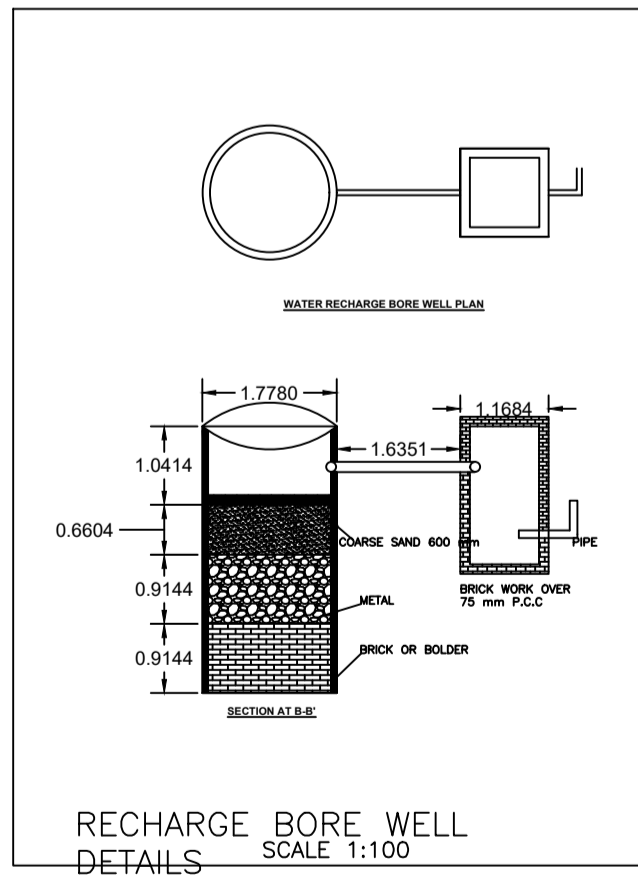
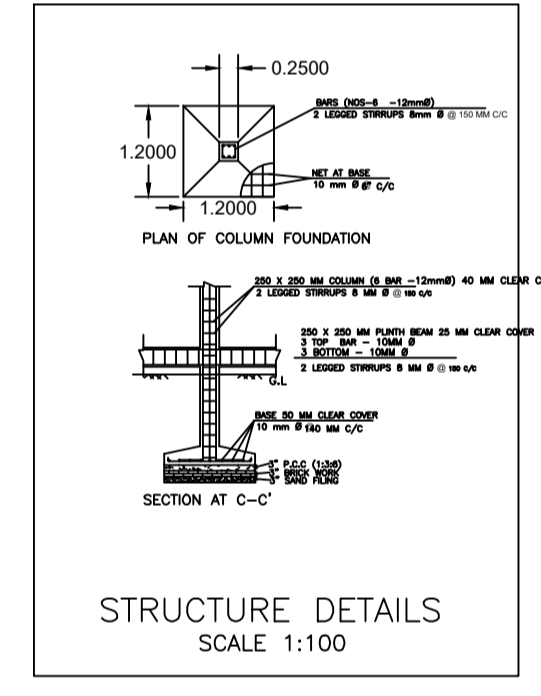
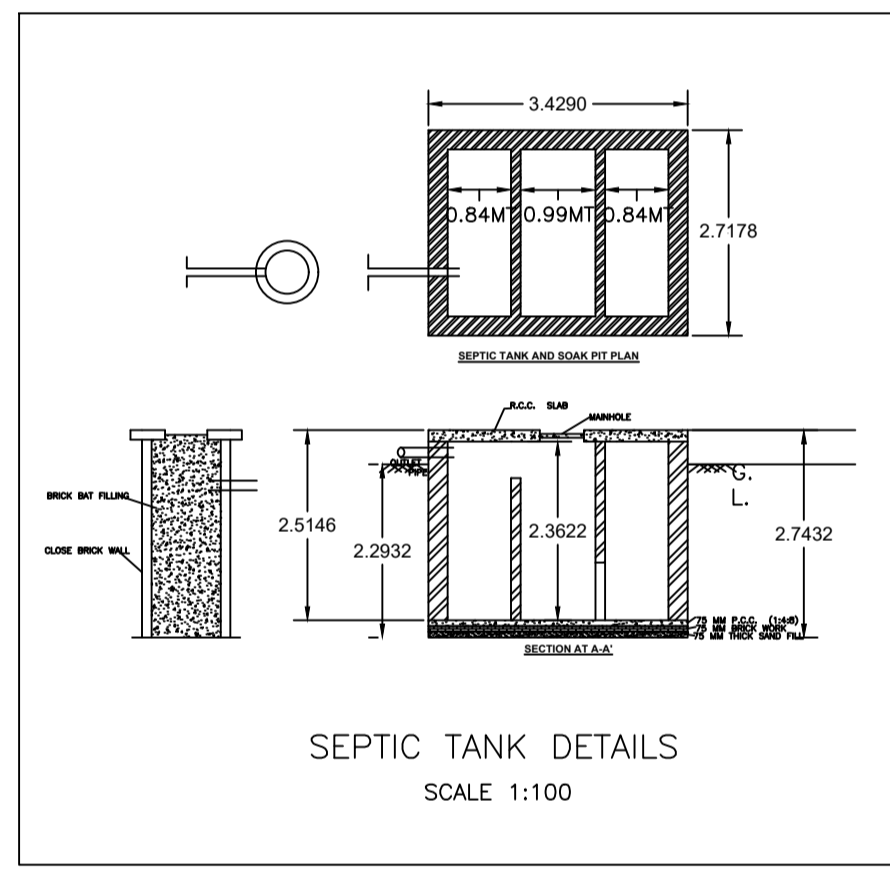
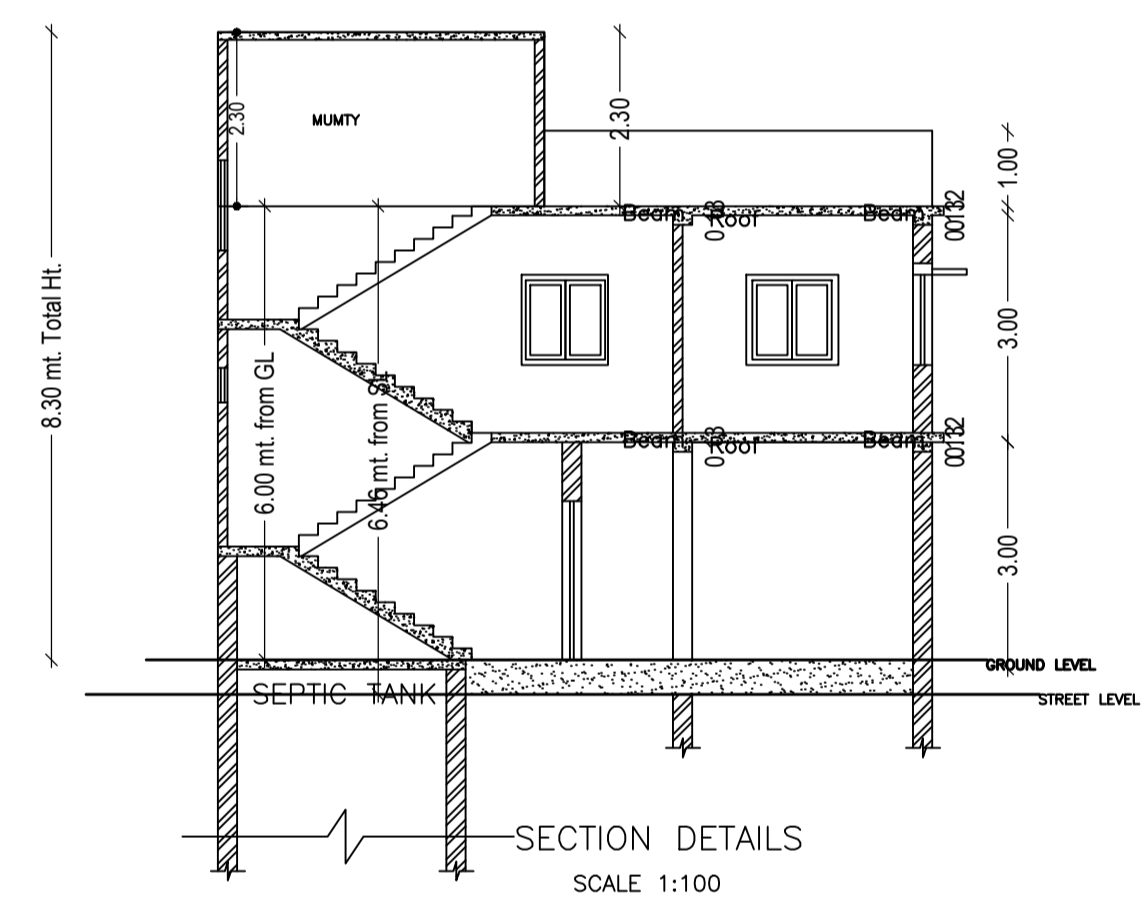

LTP NAME AND SIGNATURE	STRUCTURAL ENG'S NAME AND SIGNATURE	BUILDER NAME AND SIGNATURE	DIGITAL SIGNATURE
CHANDRA SHEKHAR THAKUR MNNP/ENG/0004/2020			