

site plan

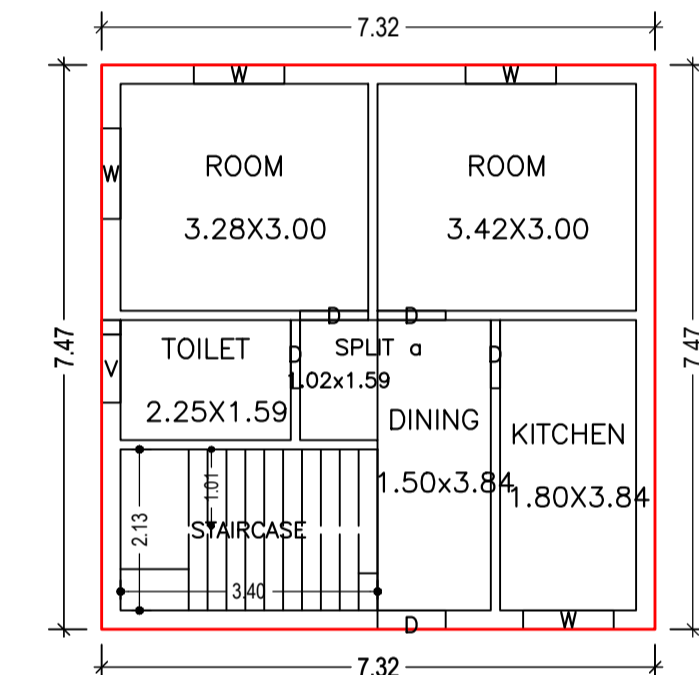

GROUND FLOOR PLAN (Proposed) (SCALE 1:100)

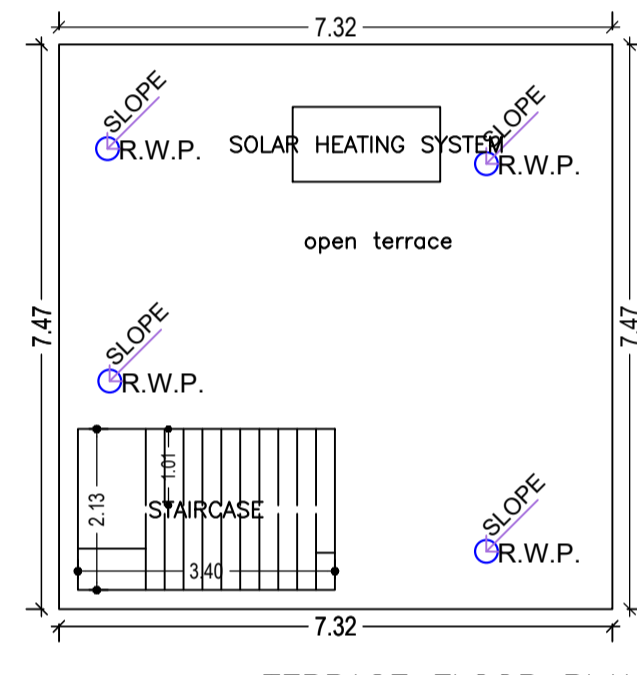

TERRACE FLOOR PLAN (SCALE 1:100)

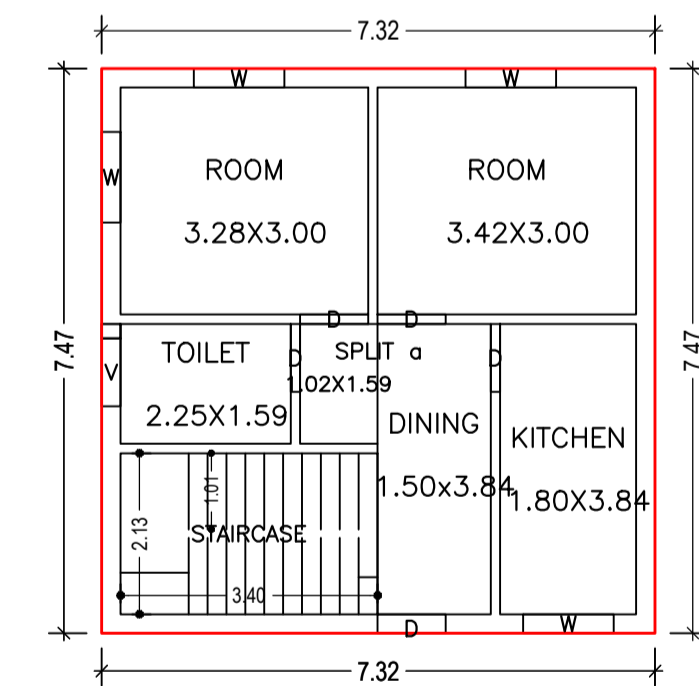

FIRST FLOOR PLAN (Proposed) (SCALE 1:100)

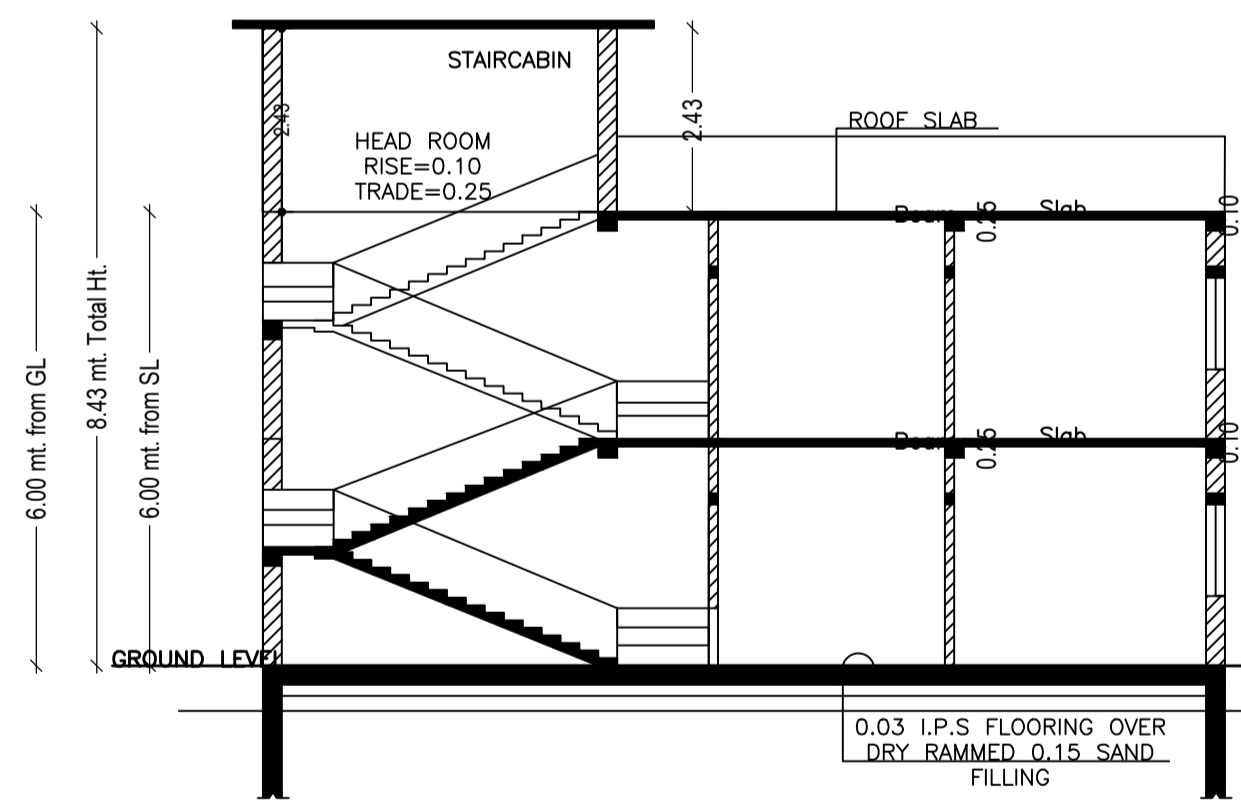

SECTION ON-XX

FRONT SIDE ELEVATION

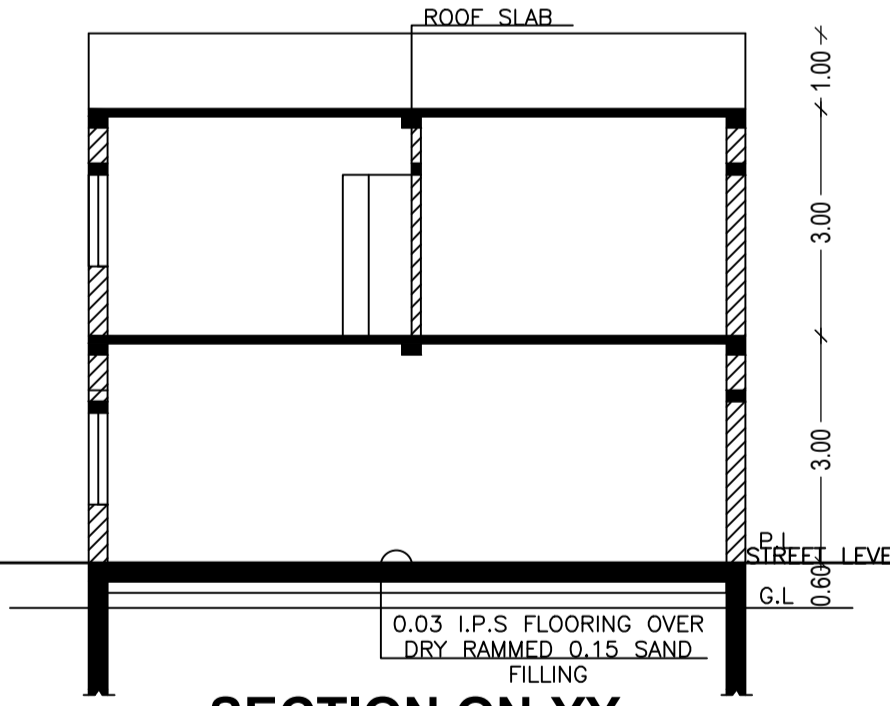

SECTION ON-YY

FAR & Tenement Details (Table 4c-1)

Building	No. of Same Bldg	Total Built Up Area (Sq.mt.)	Proposed FAR Area (Sq.mt.)	Total FAR Area (Sq.mt.)	Total Consumed Additional FAR Area (Sq.mt.)	Tnmt (No.)
A (BUILDING)	1	109.28	109.28	109.28	109.28	01
Grand Total :	1	109.28	109.28	109.28	109.28	01

Proposal Basic Information

Proposal File No.	MNNP/BI/0079/W03/2023
Owner Name	POOJA KUMARI
Khata No	26
Plot No	12
Village Name	Nimiya
Use	Residential
SubUse	Bungalow/ Dwelling / Non Apartment

AREA STATEMENT	VERSION NO.: 1.0.66
MEDINAGAR MUNICIPAL CORPORATION	VERSION DATE: 16/10/2020
PROJECT DETAIL:	
Region: JHARKHAND URBAN LOCAL BODIES	Plot Use: Residential
District: PALAMU	Plot SubUse: Bungalow/ Dwelling / Non Apartment
Authority: MEDINAGAR MUNICIPAL CORPORATION	PlotNearby/ReligiousStructure: NA
Inward No: MNNP/BI/0079/W03/2023	Plot/SubPlot No: 12
Application Type: General Proposal	North: -
Project Type: Building Permission	South: -
Nature of Development: New	East: -
Location of Development Area: Old Area	West: -
AREA DETAILS:	SQ.MT.
AREA OF PLOT (Minimum)	(A) 100.20
Deduction for NetPlot Area	
Surrender Free of Cost	10.07
Total	10.07
NET AREA OF PLOT(Gross Plot Area - Deduction from Gross Plot area)	(A-Deductions) 90.13
Deduction for Balance Plot Area(from Gross Plot Area)	
Surrender Free of Cost	10.07
Common Plot	11.26
Total	21.33
BALANCE AREA OF PLOT(Net Plot Area - Recreational/Amenity space)	(A-Deductions) 78.87
PLOT AREA FOR COVERAGE(Net Plot Area)	(A-Deductions) 90.13
Plot Area for FAR (Net Plot Area + Road/Widening Area)	(A-Deductions) 100.20
COVERAGE CHECK	
Permissible Coverage area (70.00 %)	63.09
Proposed Coverage Area (60.62 %)	54.64
Total Prop. Coverage Area (60.62 %)	54.64
Balance coverage area (9.38 %)	8.45
FAR CHECK	
Perm. FAR Area (1.500)	150.30
Total Perm. FAR area	150.30
Residential FAR	109.28
Proposed FAR Area	109.28
Total Proposed FAR Area	109.28
Consumed FAR (Factor)	1.09
Balance FAR Area	41.01
BUILT UP AREA CHECK	
Total Proposed BuiltUp Area	109.28
ARCHITECT (Regd)	CHANDRA SHEKHAR THAKUR
ENGINEER (Regd)	
SUPERVISOR (Regd)	
OWNER (Regd)	POOJA KUMARI
DEVELOPMENT AUTHORITY	LOCAL BODY

COLOR INDEX	
PLOT BOUNDARY	Black
ABUTTING ROAD	Green
PROPOSED CONSTRUCTION	Red
COMMON PLOT	Yellow
ROAD WIDENING AREA	Blue
EXISTING (To be retained)	Grey
EXISTING (To be demolished)	White

Buildingwise Floor FAR Details

Floor Name	Building Name A (BUILDING)		Total	
	Proposed Built Up Area (Sq.mt.)	Proposed FAR Area (Sq.mt.)	Total Proposed Built Up Area (Sq.mt.)	Total FAR Area (Sq.mt.)
Ground Floor	54.64	54.64	54.64	54.64
First Floor	54.64	54.64	54.64	54.64
Terrace Floor	0.00	0.00	0.00	0.00
Total :	109.28	109.28	109.28	109.28

Building USE/SUBUSE Details

Building Name	Building Use	Building SubUse	Building Structure
A (BUILDING)	Residential	Bungalow/ Dwelling / Non Apartment	Non-Highrise

Building :A (BUILDING)

Floor Name	Total Built Up Area (Sq.mt.)	Proposed FAR Area (Sq.mt.)	Total FAR Area (Sq.mt.)	Total Consumed Additional FAR Area (Sq.mt.)	Tnmt (No.)
Ground Floor	54.64	54.64	54.64	54.64	01
First Floor	54.64	54.64	54.64	54.64	00
Terrace Floor	0.00	0.00	0.00	0.00	00
Total :	109.28	109.28	109.28	109.28	01
Total Number of Same Buildings	1				
Total :	109.28	109.28	109.28	109.28	01

SCHEDULE OF DOOR:

BUILDING NAME	NAME	LENGTH	HEIGHT	NOS
A (BUILDING)	D	0.90	2.10	10

SCHEDULE OF WINDOW/VENTILATION:

BUILDING NAME	NAME	LENGTH	HEIGHT	NOS
A (BUILDING)	V	0.90	0.60	02
A (BUILDING)	W	1.20	1.20	08

UnitBUA Table for Building :A (BUILDING)

FLOOR	Name	UnitBUA Type	UnitBUA Area	Carpet Area	No. of Rooms	No. of Tenement
GROUND FLOOR PLAN	SPLIT a	FLAT	91.91	91.82	5	1
FIRST FLOOR PLAN	SPLIT a	FLAT	0.00	0.00	5	0
Total:	-	-	91.91	91.82	10	1

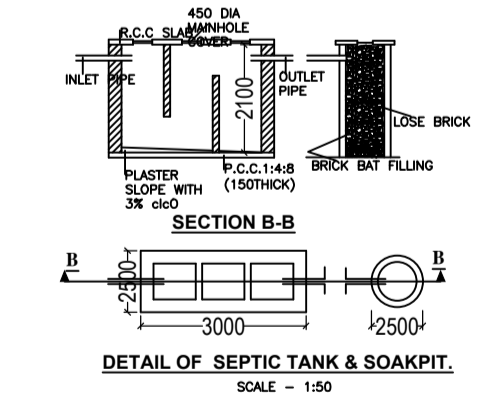

DETAIL OF SEPTIC TANK & SOAKPIT. SCALE - 1:50