

site plan

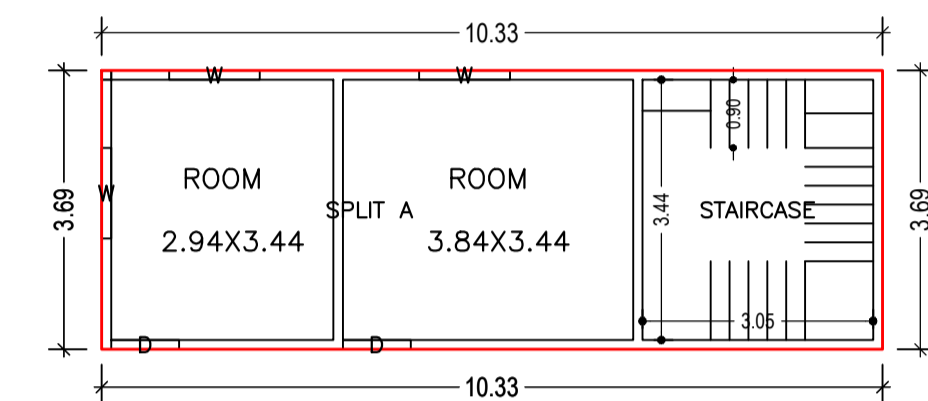

GROUND FLOOR PLAN (Proposed) (SCALE 1:100)

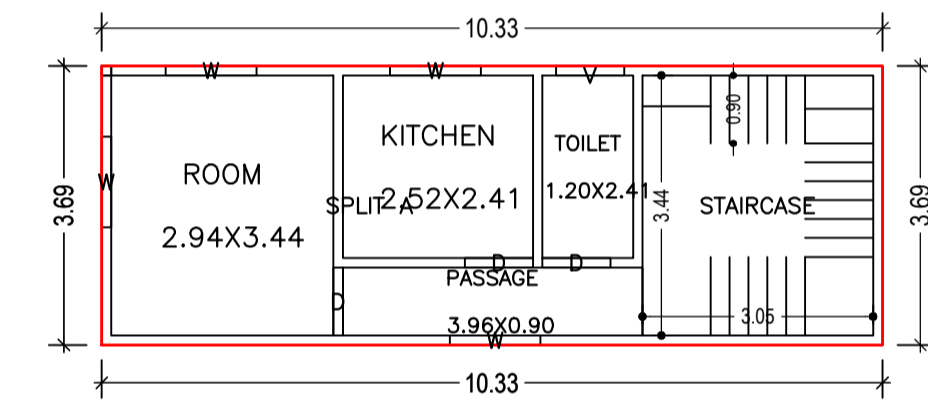

FIRST FLOOR PLAN (Proposed) (SCALE 1:100)

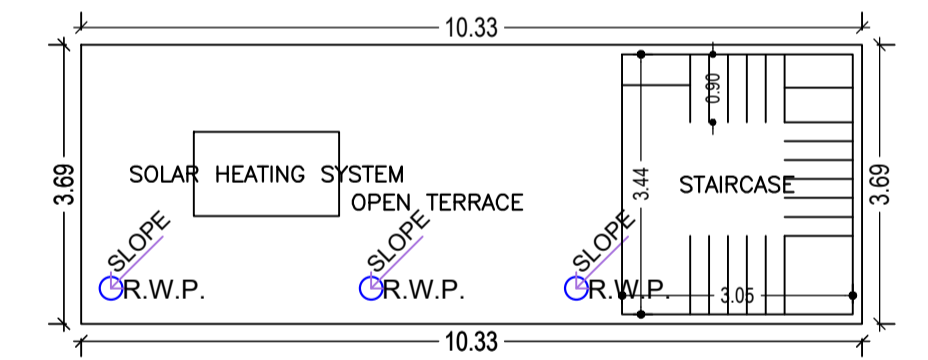

TERRACE FLOOR PLAN (SCALE 1:100)

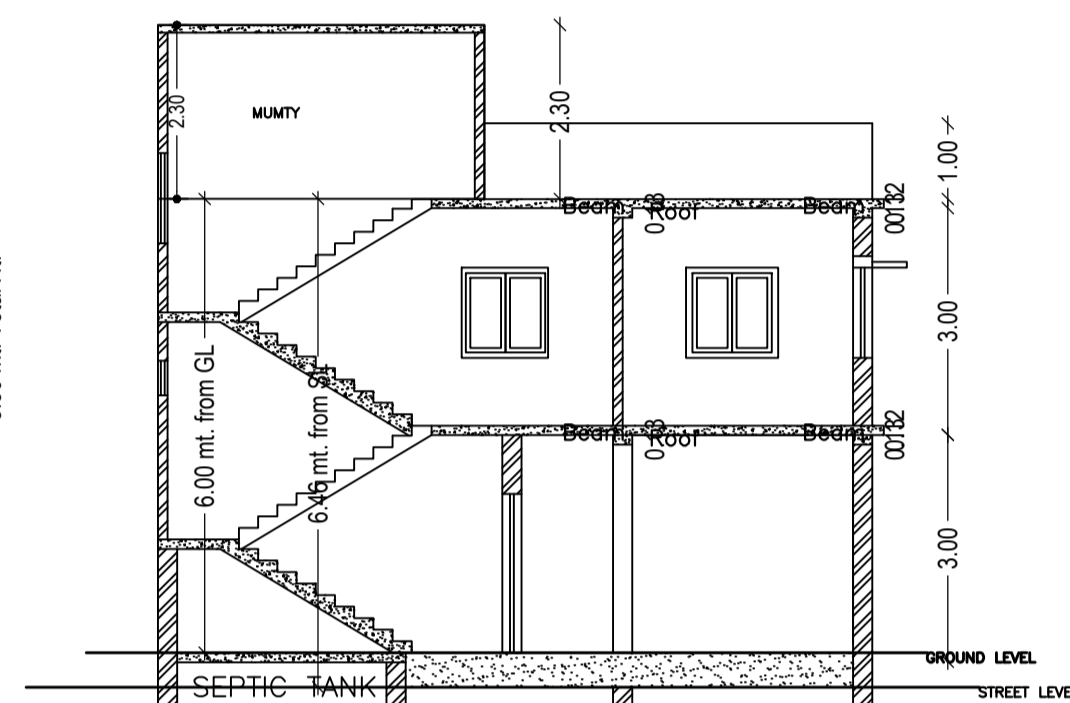

SECTION DETAILS (SCALE 1:100)

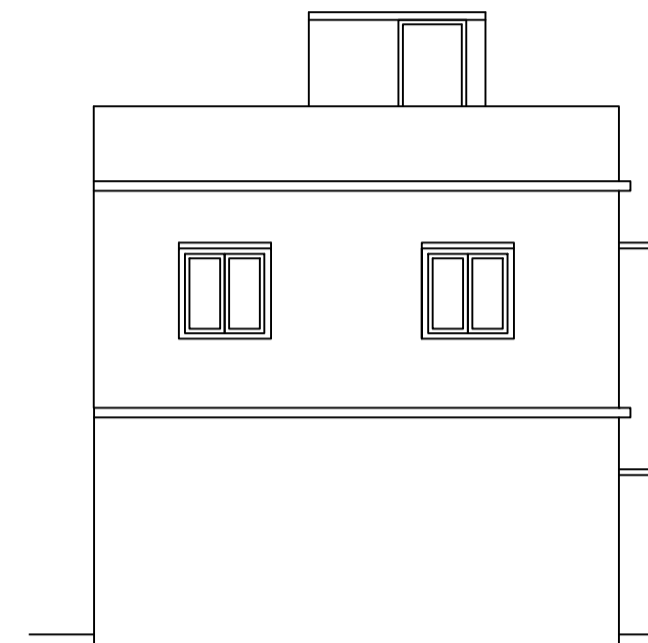

BACK ELEVATION (SCALE 1:100)

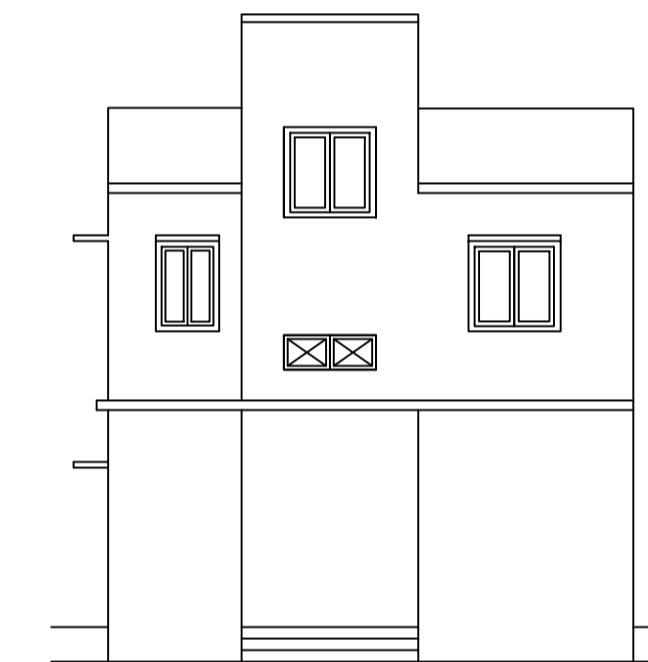

FRONT ELEVATION (SCALE 1:100)

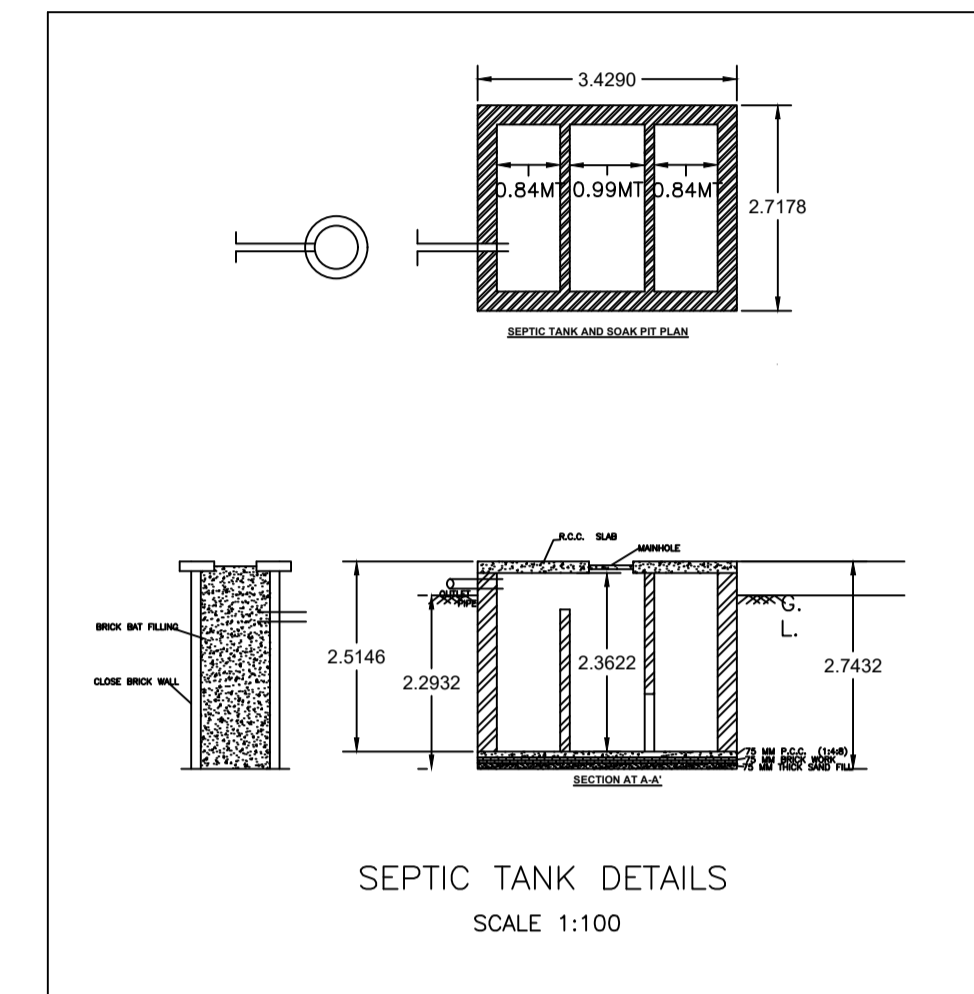

SEPTIC TANK DETAILS (SCALE 1:100)

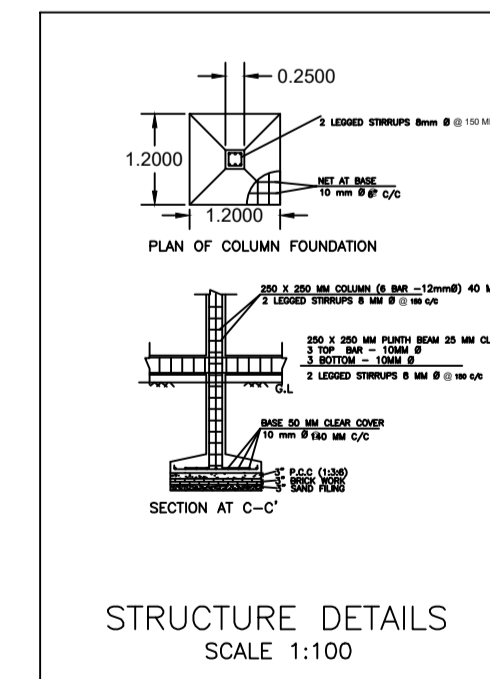

STRUCTURE DETAILS (SCALE 1:100)

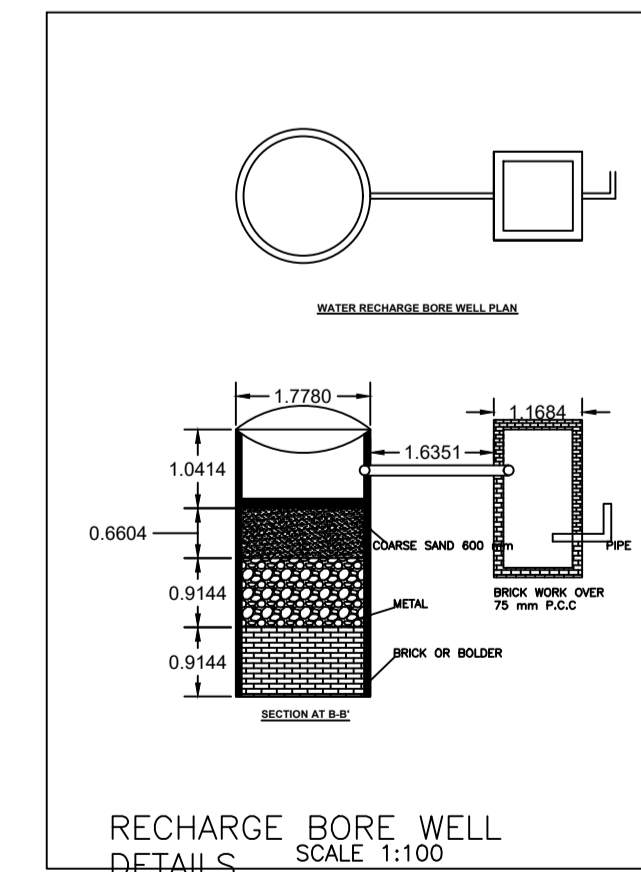

RECHARGE BORE WELL DETAILS (SCALE 1:100)

FAR & Tenement Details (Table 4c-1)

Building	No. of Same Bldg	Total Built Up Area (Sq.mt.)	Proposed FAR Area (Sq.mt.) Resi.	Total FAR Area (Sq.mt.)	Total Consumed Additional FAR Area (Sq.mt.)	Tnmt (No.)
A (BUILDING)	1	76.24	76.24	76.24	76.24	01
Grand Total :	1	76.24	76.24	76.24	76.24	01

Proposal Basic Information

Proposal File No.	MNNP/BP/0083/W18/2023
Owner Name	Chotu Tiwari
Khata No	45
Plot No	1833
Village Name	Redma
Use	Residential
SubUse	Bungalow/ Dwelling / Non Apartment

AREA STATEMENT MEDINAGAR MUNICIPAL CORPORATION	VERSION NO. : 1.0.66 VERSION DATE: 16/10/2020
PROJECT DETAIL:	
Region: JHARKHAND URBAN LOCAL BODIES	Plot Use: Residential
District: PALAMU	Plot SubUse: Bungalow/ Dwelling / Non Apartment
Authority: MEDINAGAR MUNICIPAL CORPORATION	PlotNearbyReligiousStructure: NA
Inward No: MNNP/BP/0083/W18/2023	Plot/SubPlot No: 1833
Application Type: General Proposal	North: -
Project Type: Building Permission	South: -
Nature of Development: New	East: -
Location of Development Area: New Area	West: -
AREA DETAILS:	SQ.MT.
AREA OF PLOT (Minimum)	(A) 73.87
NET AREA OF PLOT(Gross Plot Area - Deduction from Gross Plot area)	73.87
Deduction for Balance Plot Area(from Gross Plot Area)	
Common Plot	9.67
Total	9.67
BALANCE AREA OF PLOT(Net Plot Area - Recreational/Amenity space)	(A-Deductions) 64.19
PLOT AREA FOR COVERAGE(Net Plot Area)	(A-Deductions) 73.87
Plot Area for FAR (Net Plot Area + Road Widening Area)	(A-Deductions) 73.87
COVERAGE CHECK	
Permissible Coverage area ( 70.00 % )	51.71
Proposed Coverage Area ( 51.61 % )	38.12
Total Prop. Coverage Area ( 51.61 % )	38.12
Balance coverage area ( 18.40 % )	13.59
FAR CHECK	
Perm. FAR Area ( 2.500 )	184.68
Total Perm. FAR area	184.68
Residential FAR	76.23
Proposed FAR Area	76.23
Total Proposed FAR Area	76.23
Consumed FAR (Factor)	1.03
Balance FAR Area	108.45
BUILT UP AREA CHECK	
Total Proposed BuiltUp Area	76.24
ARCHITECT (Regd)	SIDDHARTHA PRIYADARSHI
ENGINEER (Regd)	
SUPERVISOR (Regd)	
OWNER (Regd)	Chotu Tiwari
DEVELOPMENT AUTHORITY	LOCAL BODY

COLOR INDEX	
PLOT BOUNDARY	Black
ABUTTING ROAD	Green
PROPOSED CONSTRUCTION	Red
COMMON PLOT	Yellow
ROAD WIDENING AREA	Blue
EXISTING (To be retained)	Orange
EXISTING (To be demolished)	White

Building :A (BUILDING)

Floor Name	Total Built Up Area (Sq.mt.)	Proposed FAR Area (Sq.mt.) Resi.	Total FAR Area (Sq.mt.)	Total Consumed Additional FAR Area (Sq.mt.)	Tnmt (No.)
Ground Floor	38.12	38.12	38.12	38.12	01
First Floor	38.12	38.12	38.12	38.12	00
Terrace Floor	0.00	0.00	0.00	0.00	00
Total :	76.24	76.24	76.24	76.24	01
Total Number of Same Buildings	1				
Total :	76.24	76.24	76.24	76.24	01

SCHEDULE OF DOOR:

BUILDING NAME	NAME	LENGTH	HEIGHT	NOS
A (BUILDING)	D	0.90	2.10	05

SCHEDULE OF WINDOW/VENTILATION:

BUILDING NAME	NAME	LENGTH	HEIGHT	NOS
A (BUILDING)	V	0.90	0.60	01
A (BUILDING)	W	1.20	1.20	07

UnitBUA Table for Building :A (BUILDING)

FLOOR	Name	UnitBUA Type	UnitBUA Area	Carpet Area	No. of Rooms	No. of Tenement
FIRST FLOOR PLAN	SPLIT A	FLAT	0.00	0.00	4	0
GROUND FLOOR PLAN	SPLIT A	FLAT	52.80	52.77	2	1
Total:	-	-	52.80	52.77	6	1

LTP NAME AND SIGNATURE	STRUCTURAL ENG'S NAME AND SIGNATURE	BUILDER NAME AND SIGNATURE	DIGITAL SIGNATURE
SIDDHARTHA PRIYADARSHI MNNP/ENG/0005/2020			