

SITE PLAN

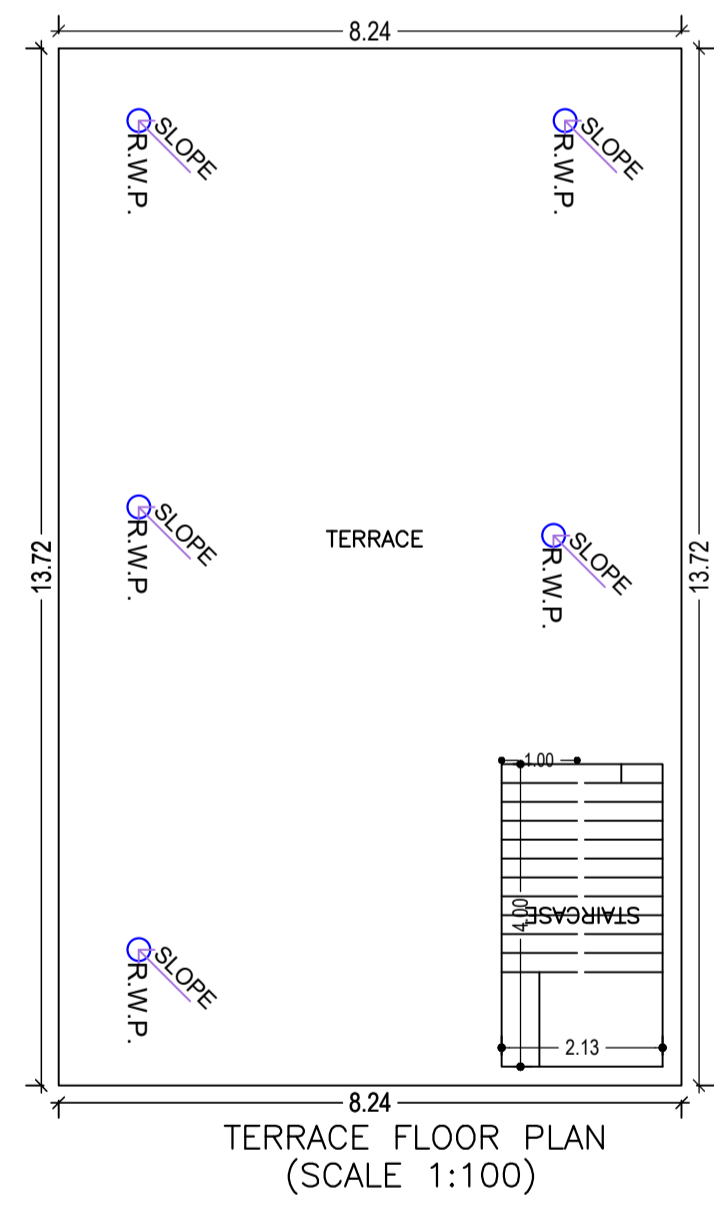
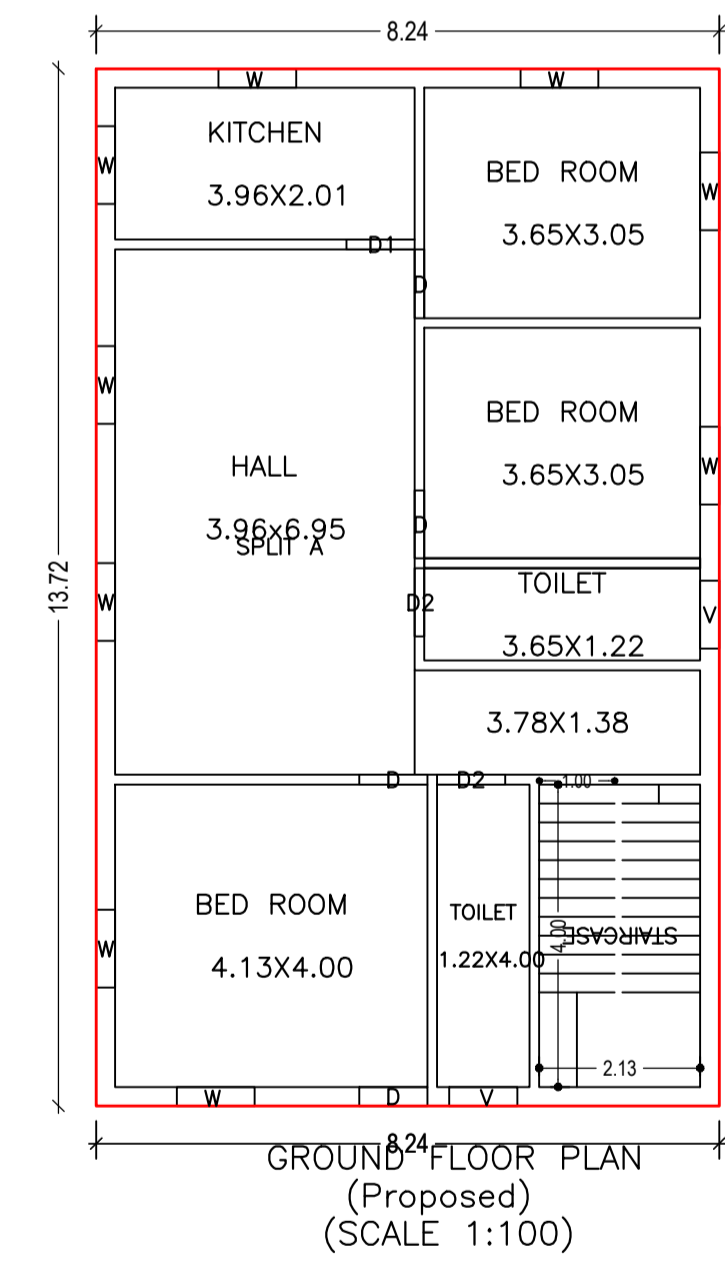

Building :A (RESIDENTIAL)

Floor Name	Total Built Up Area (Sq.mt.)	Proposed FAR Area (Sq.mt.)	Total FAR Area (Sq.mt.)	Total Consumed Additional FAR Area (Sq.mt.)	Tnmt (No.)
Ground Floor	113.03	113.03	113.03	113.03	01
Terrace Floor	0.00	0.00	0.00	0.00	00
Total :	113.03	113.03	113.03	113.03	01
Total Number of Same Buildings	1				
Total :	113.03	113.03	113.03	113.03	01

SCHEDULE OF DOOR:

BUILDING NAME	NAME	LENGTH	HEIGHT	NOS
A (RESIDENTIAL)	D	0.90	2.10	03
A (RESIDENTIAL)	D2	0.90	2.10	02
A (RESIDENTIAL)	D1	0.90	2.10	01
A (RESIDENTIAL)	D	0.91	2.10	01

SCHEDULE OF WINDOW/VENTILATION:

BUILDING NAME	NAME	LENGTH	HEIGHT	NOS
A (RESIDENTIAL)	V	0.90	0.60	02
A (RESIDENTIAL)	W	1.03	1.20	09

UnitBUA Table for Building :A (RESIDENTIAL)

FLOOR	Name	UnitBUA Type	UnitBUA Area	Carpet Area	No. of Rooms	No. of Tenement
GROUND FLOOR PLAN	SPLIT A	FLAT	102.91	102.43	7	1
Total:	-	-	102.91	102.43	7	1

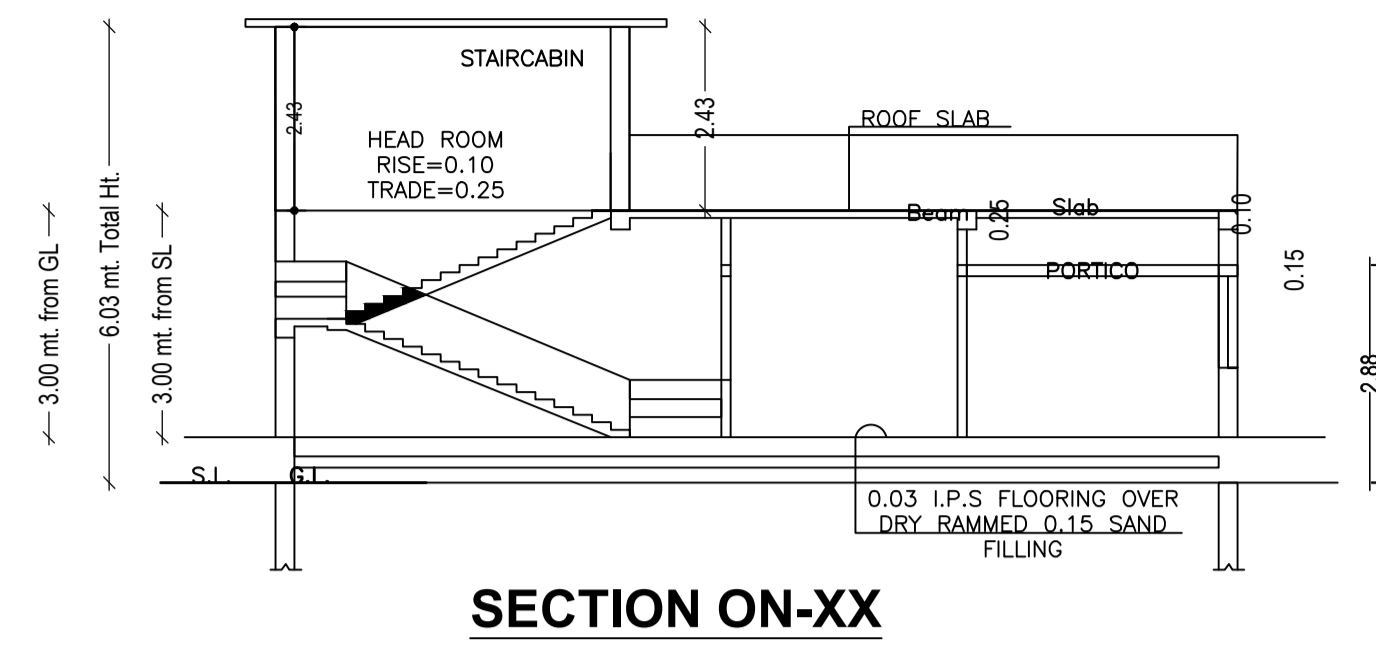

SECTION ON-XX

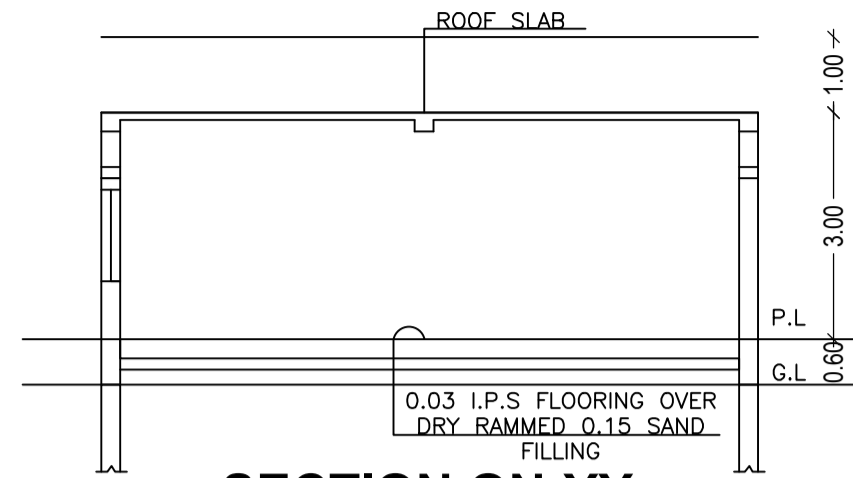

SECTION ON-YY

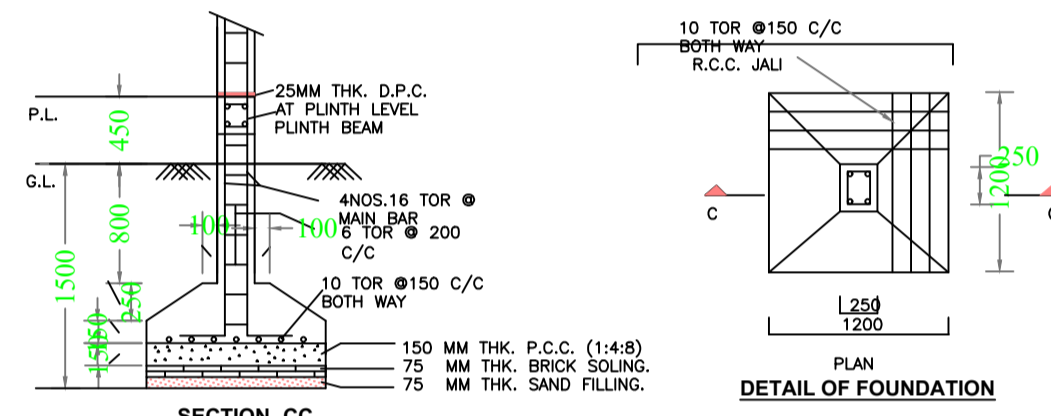

STRUCTURAL DETAIL

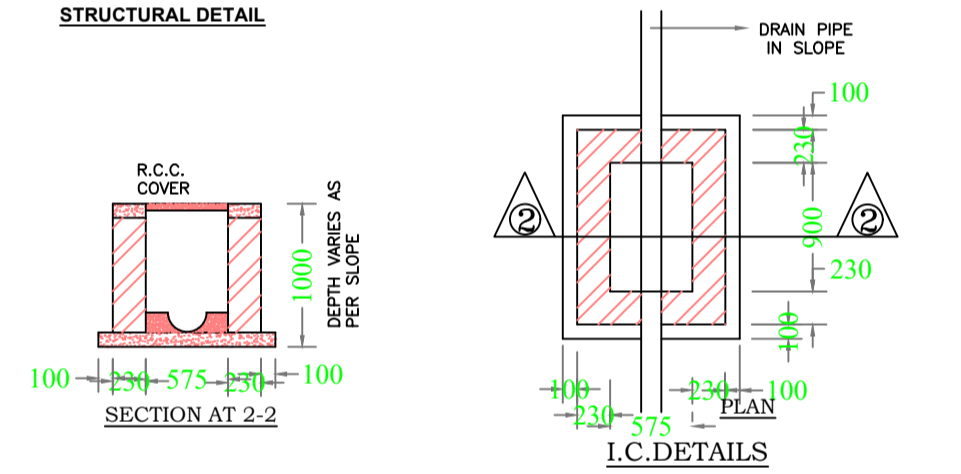

I.C. DETAILS

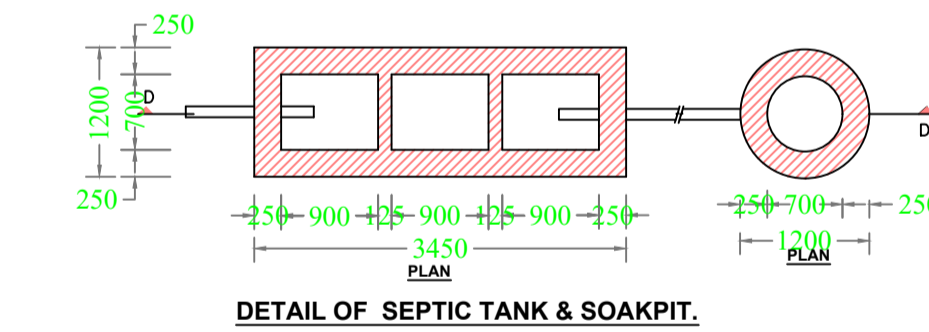

DETAIL OF SEPTIC TANK & SOAKPIT.

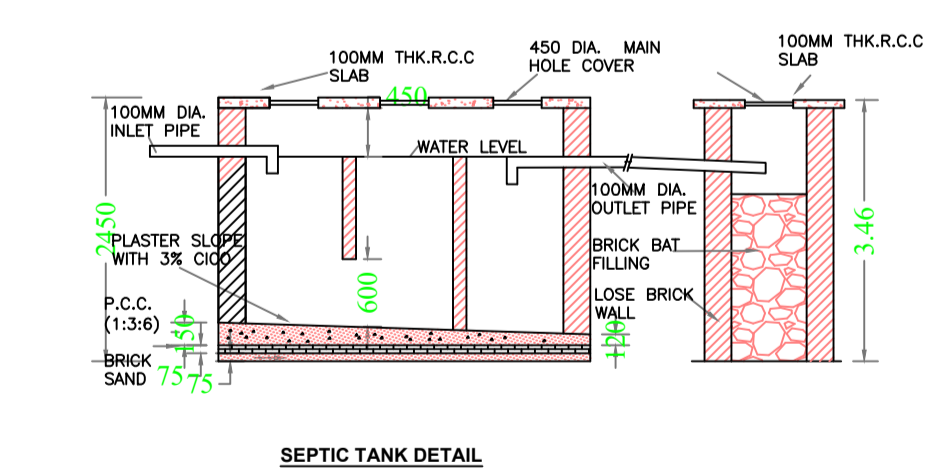

SEPTIC TANK DETAIL

FAR & Tenement Details (Table 4c-1)

Building	No. of Same Bldg	Total Built Up Area (Sq.mt.)	Proposed FAR Area (Sq.mt.)	Total FAR Area (Sq.mt.)	Total Consumed Additional FAR Area (Sq.mt.)	Tnmt (No.)
A (RESIDENTIAL)	1	113.03	113.03	113.03	113.03	01
Grand Total :	1	113.03	113.03	113.03	113.03	01

Proposal Basic Information

Proposal File No.	MNNP/BP/0155/W04/2023
Owner Name	Govind Mehta
Khata No	101
Plot No	146
Village Name	Baralota
Use	Residential
SubUse	Bungalow/ Dwelling / Non Apartment

AREA STATEMENT	VERSION NO. : 1.0.66	SQ.MT.
AREA OF PLOT (Minimum)	(A)	161.93
NET AREA OF PLOT (Gross Plot Area - Deduction from Gross Plot area)	(A-Deductions)	161.93
Deduction for Balance Plot Area (from Gross Plot Area)		
Common Plot		13.71
Total		13.71
BALANCE AREA OF PLOT (Net Plot Area - Recreational/Amenity space)	(A-Deductions)	148.22
PLOT AREA FOR COVERAGE (Net Plot Area)	(A-Deductions)	161.93
Plot Area for FAR (Net Plot Area + Road Widening Area)	(A-Deductions)	161.93
COVERAGE CHECK		
Permissible Coverage area (70.00 %)		113.35
Proposed Coverage Area (69.80 %)		113.03
Total Prop. Coverage Area (69.8 %)		113.03
Balance coverage area (0.20 %)		0.32
FAR CHECK		
Perm. FAR Area (2.500)		404.82
Total Perm. FAR area		404.82
Residential FAR		113.03
Proposed FAR Area		113.03
Total Proposed FAR Area		113.03
Consumed FAR (Factor)		0.70
Balance FAR Area		291.79
BUILT UP AREA CHECK		
Total Proposed BuiltUp Area		113.03
ARCHITECT (Regd)		RANJIT KUMAR
ENGINEER (Regd)		
SUPERVISOR (Regd)		
OWNER (Regd)		Govind Mehta
DEVELOPMENT AUTHORITY		LOCAL BODY

COLOR INDEX

PLOT BOUNDARY	[Red Line]
ABUTTING ROAD	[Green Line]
PROPOSED CONSTRUCTION	[Yellow Line]
COMMON PLOT	[Blue Line]
ROAD WIDENING AREA	[Orange Line]
EXISTING (To be retained)	[Grey Line]
EXISTING (To be demolished)	[Black Line]

Buildingwise Floor FAR Details

Floor Name	Building Name A (RESIDENTIAL)		Total	
	Proposed Built Up Area (Sq.mt.)	Proposed FAR Area (Sq.mt.)	Total Proposed Built Up Area (Sq.mt.)	Total FAR Area (Sq.mt.)
Ground Floor	113.03	113.03	113.03	113.03
Terrace Floor	0.00	0.00	0.00	0.00
Total :	113.03	113.03	113.03	113.03

Building USE/SUBUSE Details

Building Name	Building Use	Building SubUse	Building Structure
A (RESIDENTIAL)	Residential	Bungalow/ Dwelling / Non Apartment	Non-Highrise

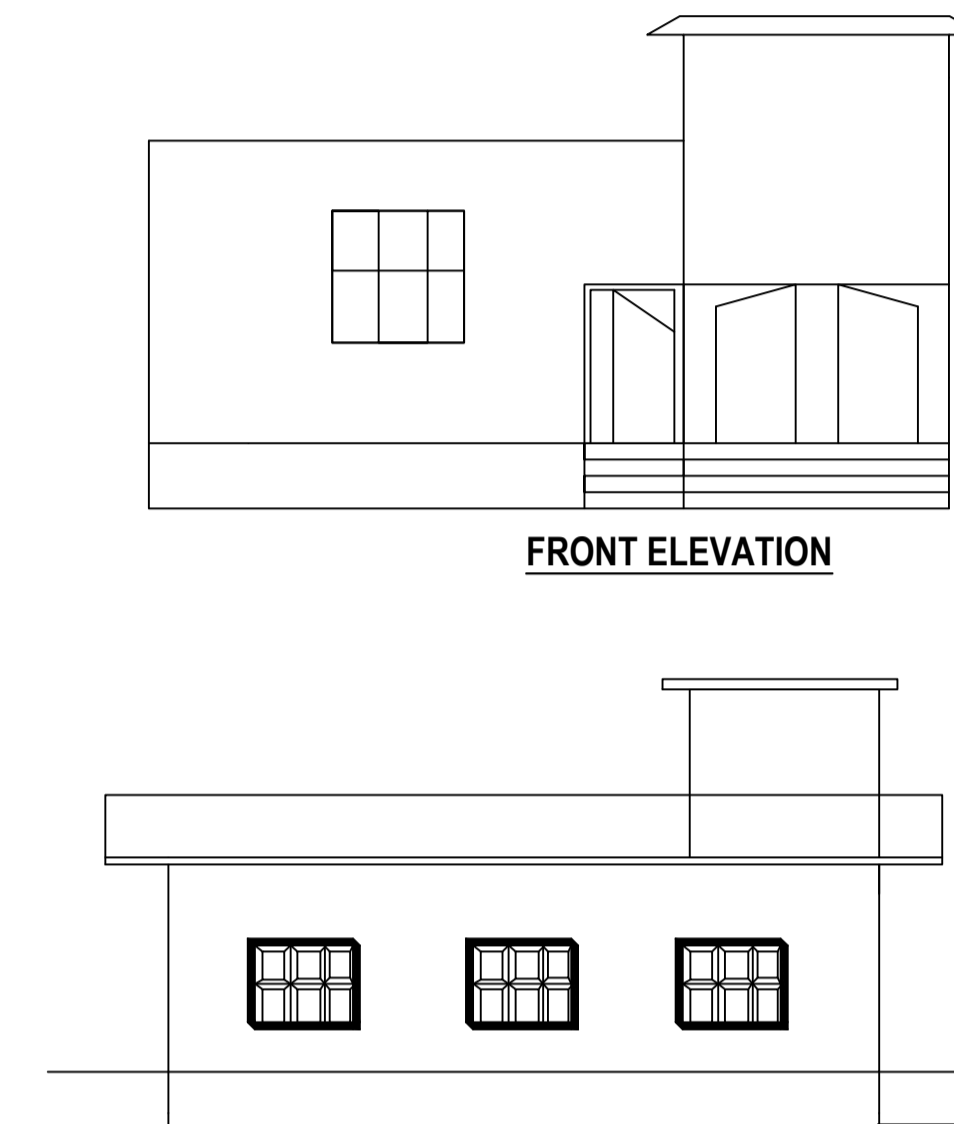

FRONT ELEVATION

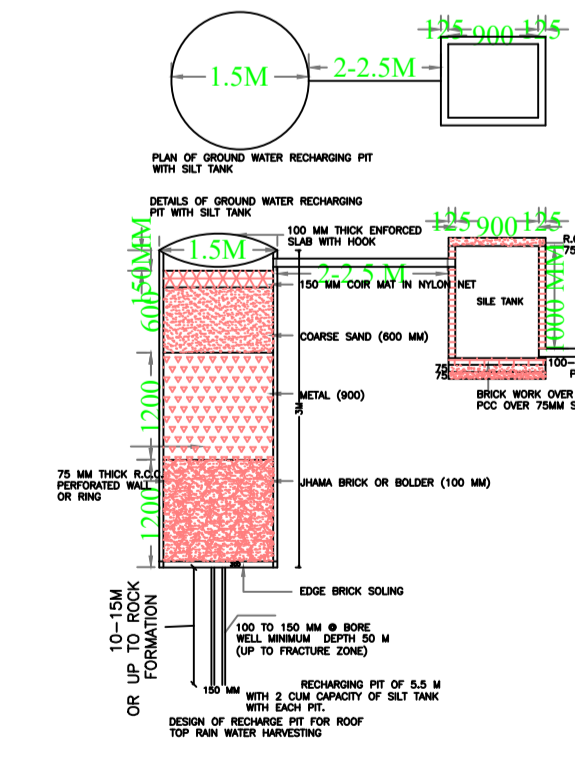

RAIN WATER STORAGE TANK DETAIL

LTP NAME AND SIGNATURE	STRUCTURAL ENG'S NAME AND SIGNATURE	BUILDER NAME AND SIGNATURE	DIGITAL SIGNATURE
RANJIT KUMAR MNNP/ENG/0001/2016			