

Proposal Basic Information

Proposal File No.	MNNP/BP/0003/W08/2024
Owner Name	Manju Devi
Khata No	32
Plot No	21
Village Name	Baralota
Use	Residential
SubUse	Bungalow Dwelling / Non Apartment

FAR & Tenement Details (Table 4c-1)

Building	No. of Same Bldg	Total Built Up Area (Sq.mt.)	Proposed FAR Area (Sq.mt.) Resi.	Total FAR Area (Sq.mt.)	Total Consumed Additional FAR Area (Sq.mt.)	Tnmt (No.)
A (RESIDENTIAL)	1	183.08	183.08	183.08	183.08	01
Grand Total :	1	183.08	183.08	183.08	183.08	01

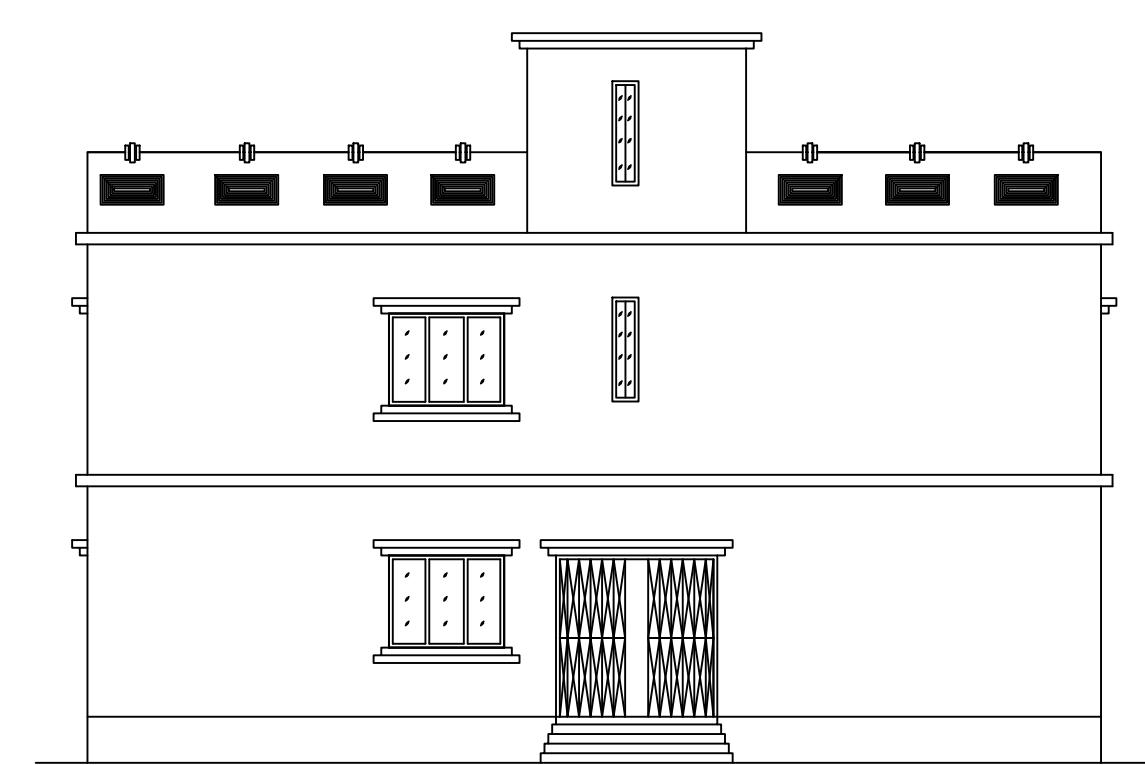
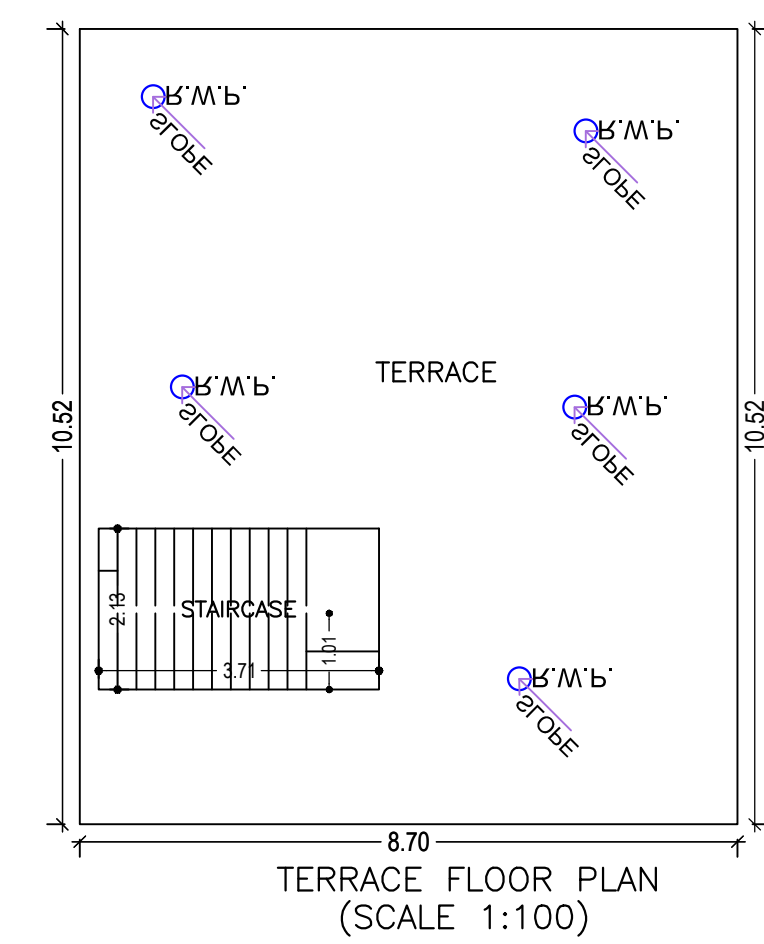
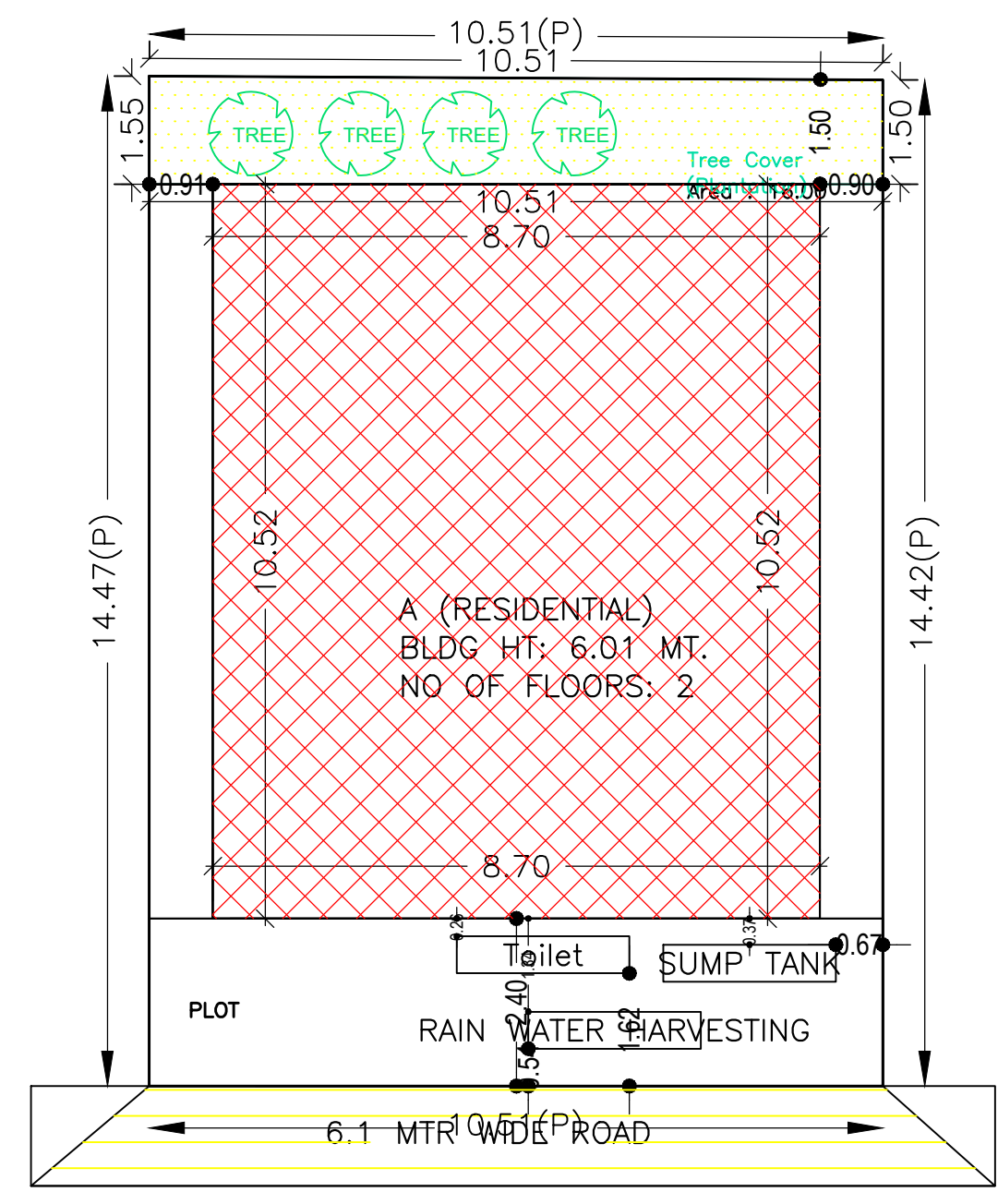

CROSS ELEVATION

AREA STATEMENT		VERSION NO. : 1.0.68
MEDINAGAR MUNICIPAL CORPORATION		VERSION DATE: 16/10/2020
PROJECT DETAIL:		
Region : JHARKHAND URBAN	Plot Use: Residential	
Local Bodies : PALAMU	Plot SubUse: Bungalow/ Dwelling / Non Apartment	
District : PALAMU	Plot SubUse: Bungalow/ Dwelling / Non Apartment	
Authority: MEDINAGAR MUNICIPAL CORPORATION	Plot/Nearby/Religious/Structure: NA	
Inward No: MNNP/BP/0003/W08/2024	Plot/SubPlot No: 21	
Application Type: General Proposal	North: -	
Project Type: Building Permission	South: -	
Nature of Development: New	East: -	
Location of Development Area: Old Area	West: -	
AREA DETAILS:		
AREA OF PLOT (Minimum)	(A)	SQ.MT. 151.81
NET AREA OF PLOT(Gross Plot Area - Deduction from Gross Plot area)	(A-Deductions)	151.81
Deduction for Balance Plot Area(from Gross Plot Area)		
Common Plot		16.00
Total		16.00
BALANCE AREA OF PLOT(Net Plot Area - Recreational/Amenity space)	(A-Deductions)	135.81
PLOT AREA FOR COVERAGE(Net Plot Area)	(A-Deductions)	151.81
Plot Area for FAR (Net Plot Area + Road Widening Area)	(A-Deductions)	151.81
COVERAGE CHECK		
Permissible Coverage area (70.00 %)		106.27
Proposed Coverage Area (60.30 %)		91.54
Total Prop. Coverage Area (60.3 %)		91.54
Balance coverage area (9.70 %)		14.73
FAR CHECK		
Perm. FAR Area (2.500)		379.52
Total Perm. FAR area		379.52
Residential FAR		183.08
Proposed FAR Area		183.08
Total Proposed FAR Area		183.08
Consumed FAR (Factor)		1.21
Balance FAR Area		196.44
BUILT UP AREA CHECK		
Total Proposed BuiltUp Area		183.08
ARCHITECT (Regd)	RANJIT KUMAR	
ENGINEER (Regd)		
SUPERVISOR (Regd)		
OWNER (Regd)	Manju Devi	
DEVELOPMENT AUTHORITY		LOCAL BODY

SITE PLAN

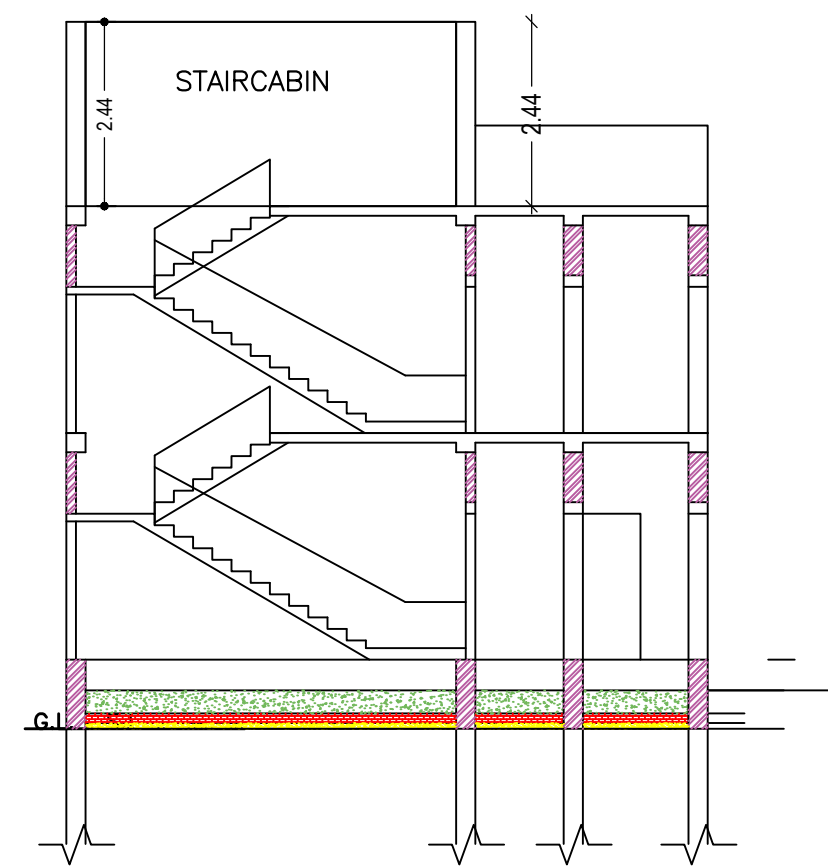
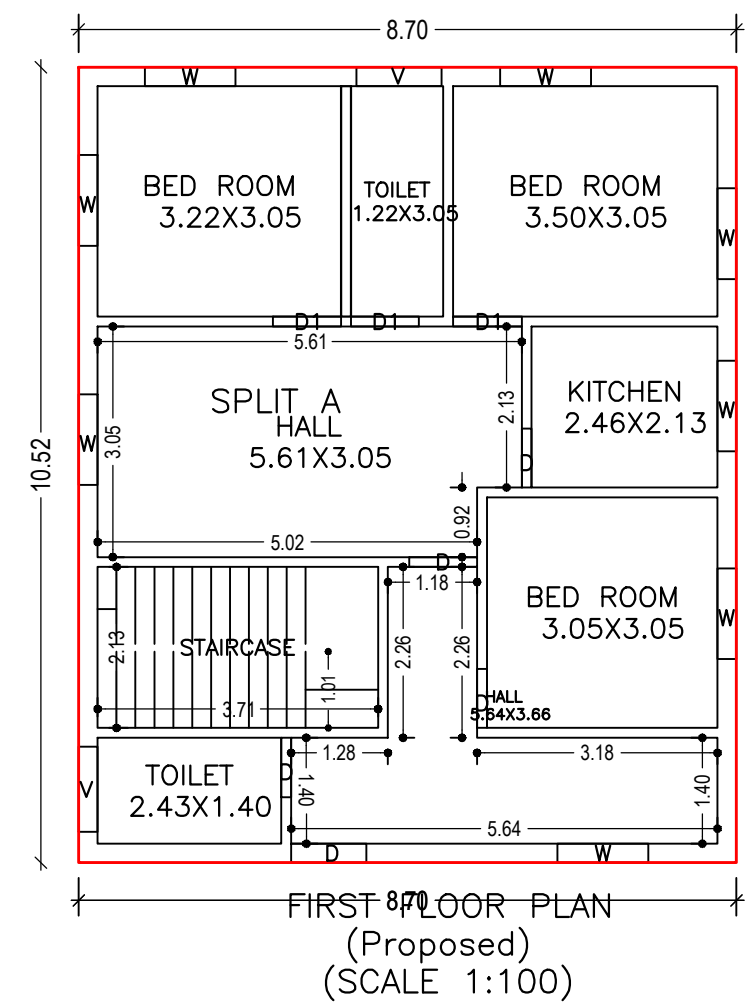
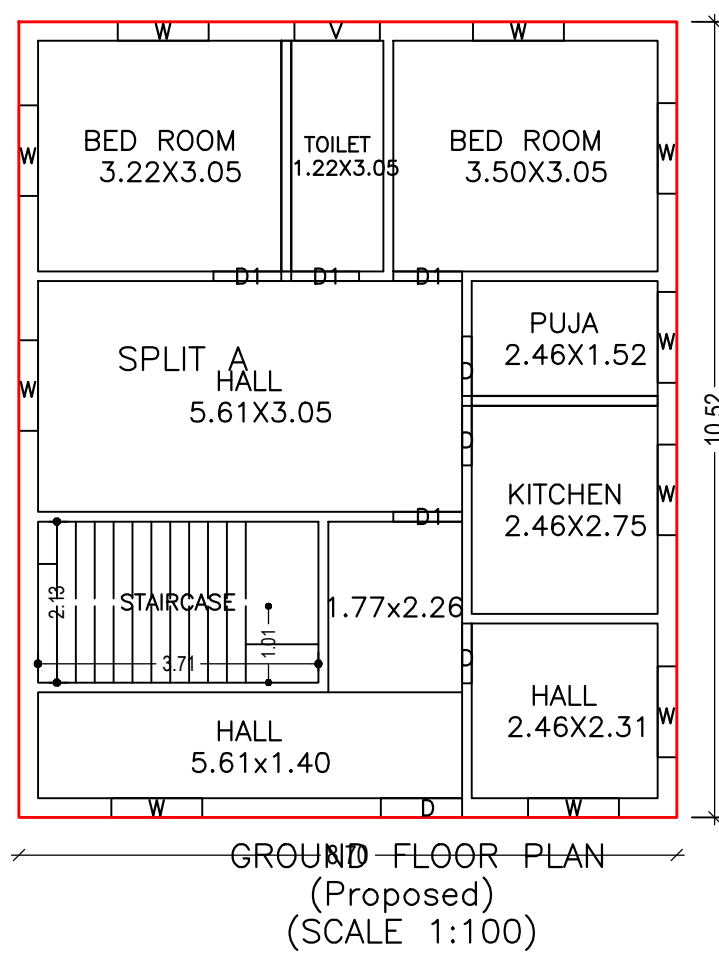

CROSS SECTION (A)

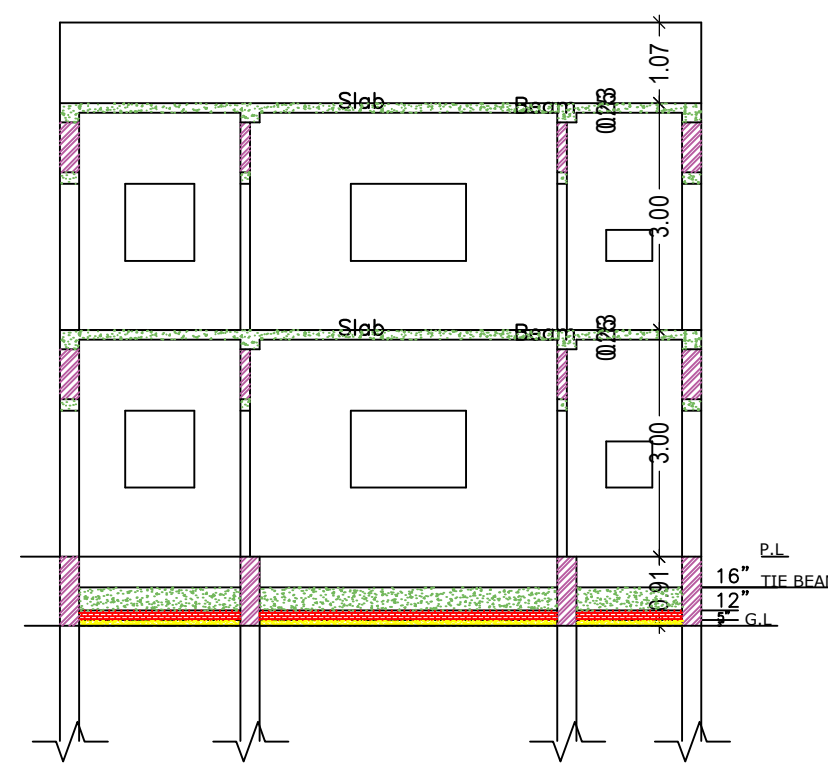

CROSS SECTION (B)

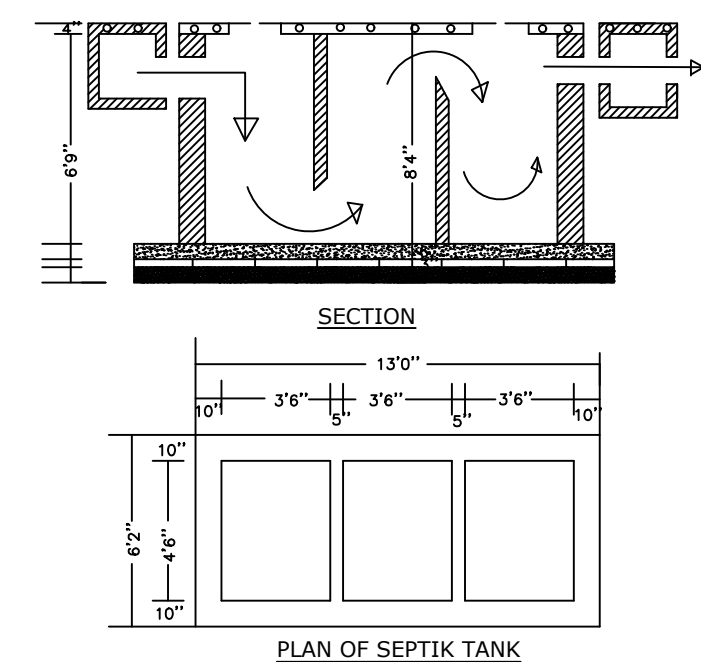

PLAN OF SEPTIK TANK

COLOR INDEX	
PLOT BOUNDARY	Black
ABUTTING ROAD	Red
PROPOSED CONSTRUCTION	Green
COMMON PLOT	Yellow
ROAD WIDENING AREA	Blue
EXISTING (To be retained)	Orange
EXISTING (To be demolished)	Light Blue

Floor Name	Total Built Up Area (Sq.mt.)	Proposed FAR Area (Sq.mt.) Resi.	Total FAR Area (Sq.mt.)	Total Consumed Additional FAR Area (Sq.mt.)	Tnmt (No.)
Ground Floor	91.54	91.54	91.54	91.54	01
First Floor	91.54	91.54	91.54	91.54	00
Terrace Floor	0.00	0.00	0.00	0.00	00
Total :	183.08	183.08	183.08	183.08	01

SCHEDULE OF DOOR:

BUILDING NAME	NAME	LENGTH	HEIGHT	NOS
A (RESIDENTIAL)	D	0.78	2.10	02
A (RESIDENTIAL)	D	0.79	2.10	04
A (RESIDENTIAL)	D1	0.90	2.10	04
A (RESIDENTIAL)	D	0.90	2.10	01
A (RESIDENTIAL)	D1	0.91	2.10	03
A (RESIDENTIAL)	D	0.99	2.10	01
A (RESIDENTIAL)	D	1.07	2.10	01

SCHEDULE OF WINDOW/VENTILATION:

BUILDING NAME	NAME	LENGTH	HEIGHT	NOS
A (RESIDENTIAL)	V	1.13	0.90	03
A (RESIDENTIAL)	W	1.20	1.20	18

UnitBUA Table for Building :A (RESIDENTIAL)

FLOOR	Name	UnitBUA Type	UnitBUA Area	Carpet Area	No. of Rooms	No. of Tenement
GROUND FLOOR PLAN	SPLIT A	FLAT	166.21	165.10	8	1
FIRST FLOOR PLAN	SPLIT A	FLAT	0.00	0.00	8	0
Total:	-	-	166.21	165.10	16	1

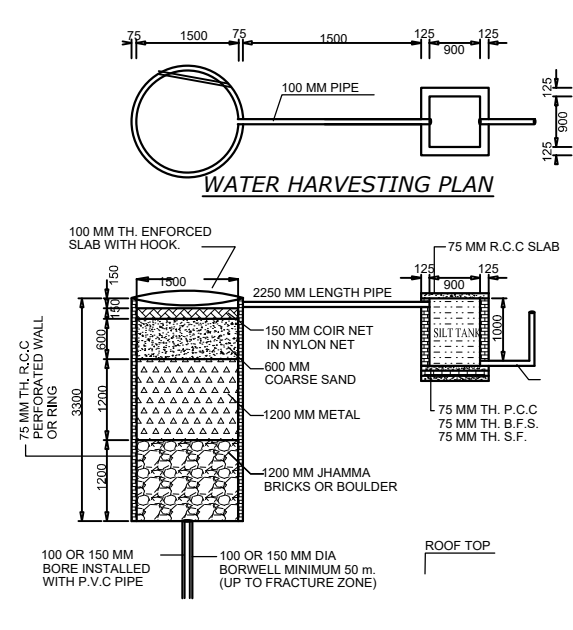
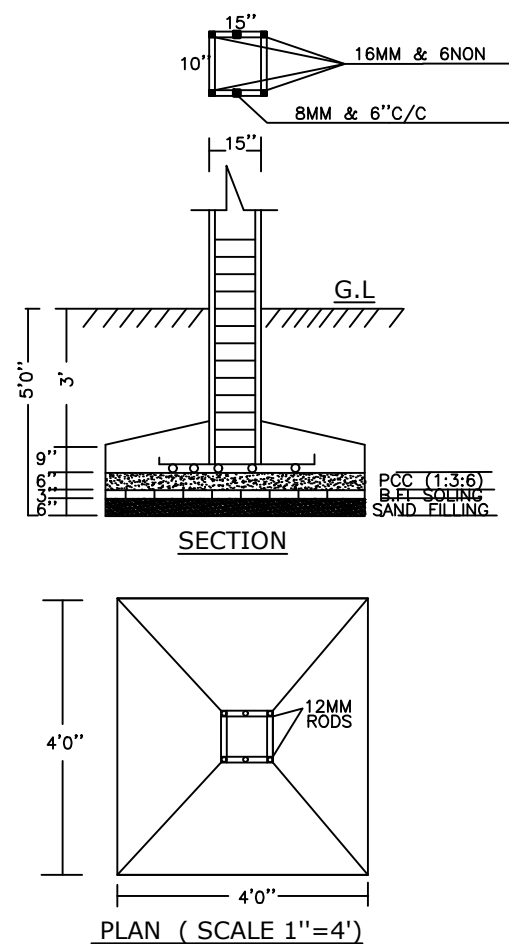

Buildingwise Floor FAR Details

Floor Name	Building Name A (RESIDENTIAL)		Total	
	Proposed Built Up Area (Sq.mt.)	Proposed FAR Area (Sq.mt.)	Total Proposed Built Up Area (Sq.mt.)	Total FAR Area (Sq.mt.)
Ground Floor	91.54	91.54	91.54	91.54
First Floor	91.54	91.54	91.54	91.54
Terrace Floor	0.00	0.00	0.00	0.00
Total :	183.08	183.08	183.08	183.08

Building USE/SUBUSE Details

Building Name	Building Use	Building SubUse	Building Structure
A (RESIDENTIAL)	Residential	Bungalow Dwelling / Non Apartment	Non-Highrise

LTP NAME AND SIGNATURE	STRUCTURAL ENG'S NAME AND SIGNATURE	BUILDER NAME AND SIGNATURE	DIGITAL SIGNATURE
RANJIT KUMAR MNNP/ENG/0001/2016			