

Proposal Basic Information	
Proposal File No.	MNNP/BI/0018/W18/2023
Owner Name	Kanak Kumari
Khata No	183
Plot No	677
Village Name	Redma
Use	Residential
SubUse	Bungalow/ Dwelling / Non Apartment

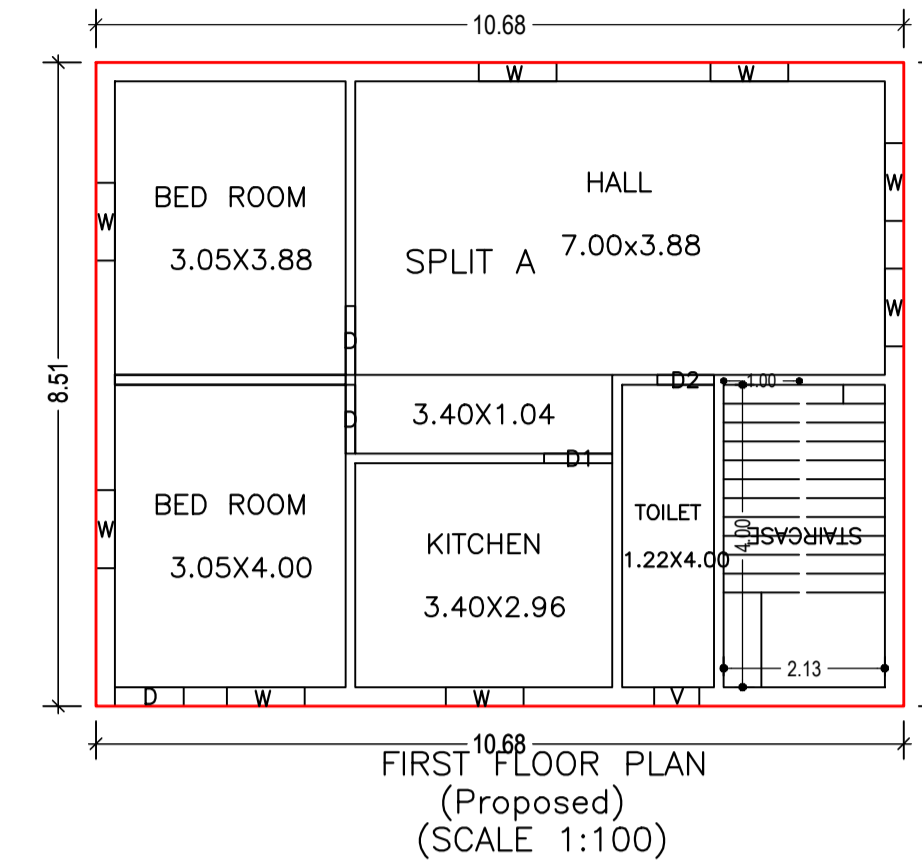

AREA STATEMENT		VERSION NO.:	1.0.65
MEDININAGAR MUNICIPAL CORPORATION		VERSION DATE: 16/10/2020	
<b>PROJECT DETAIL:</b>			
Region: JHARKHAND URBAN LOCAL BODIES	Plot Use: Residential		
District: PALAMU	Plot SubUse: Bungalow/ Non Apartment		
Authority: MEDININAGAR MUNICIPAL CORPORATION	PlotNearby/ReligiousStructure: NA		
Inward No: MNNP/BI/0018/W18/2023	Plot/SubPlot No: 677		
Application Type: General Proposal	North: -		
Project Type: Building Permission	South: -		
Nature of Development: New	East: -		
Location of Development Area: Old Area	West: -		
<b>AREA DETAILS:</b>		SQ.MT.	
AREA OF PLOT (Minimum)	(A)	191.45	
Deduction for NetPlot Area			
Surrender Free of Cost		22.48	
Total		168.97	
<b>NET AREA OF PLOT (Gross Plot Area - Deduction from Gross Plot area)</b>		(A-Deductions)	
Deduction for Balance Plot Area (from Gross Plot Area)			
Surrender Free of Cost		22.48	
Common Plot		18.74	
Total		41.23	
<b>BALANCE AREA OF PLOT (Net Plot Area - Recreational/Amenity space)</b>		(A-Deductions)	
Total		150.22	
<b>PLOT AREA FOR COVERAGE (Net Plot Area)</b>		(A-Deductions)	
Plot Area for FAR (Net Plot Area + Road Widening Area)		(A-Deductions)	
Total		191.45	
<b>COVERAGE CHECK</b>			
Permissible Coverage area ( 70.00 % )		118.28	
Proposed Coverage Area ( 53.81 % )		90.93	
Total Prop. Coverage Area ( 53.81 % )		90.93	
Balance coverage area ( 16.19 % )		27.35	
<b>FAR CHECK</b>			
Perm. FAR Area ( 1.200 )		229.74	
Total Perm. FAR area		229.74	
Residential FAR		181.86	
Proposed FAR Area		181.86	
Total Proposed FAR Area		181.86	
Consumed FAR (Factor)		0.95	
Balance FAR Area		47.88	
<b>BUILT UP AREA CHECK</b>			
Total Proposed BuiltUp Area		181.86	
ARCHITECT (Regd)		RANJIT KUMAR	
ENGINEER (Regd)			
SUPERVISOR (Regd)			
OWNER (Regd)		Kanak Kumari	
DEVELOPMENT AUTHORITY		LOCAL BODY	

**CROSS SECTION (A)**

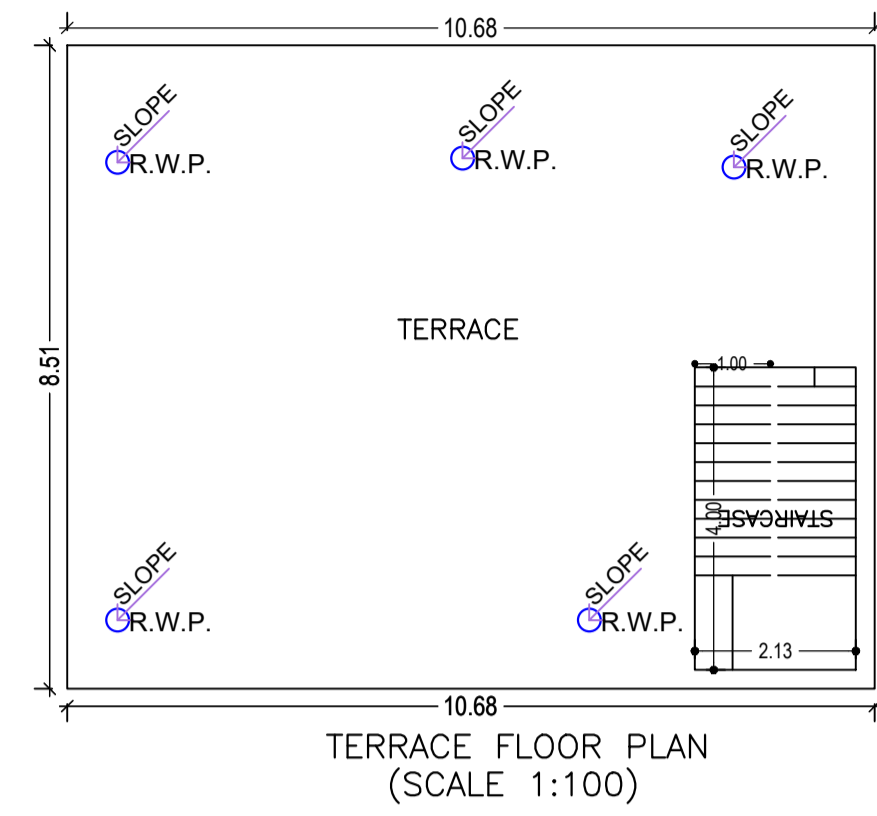
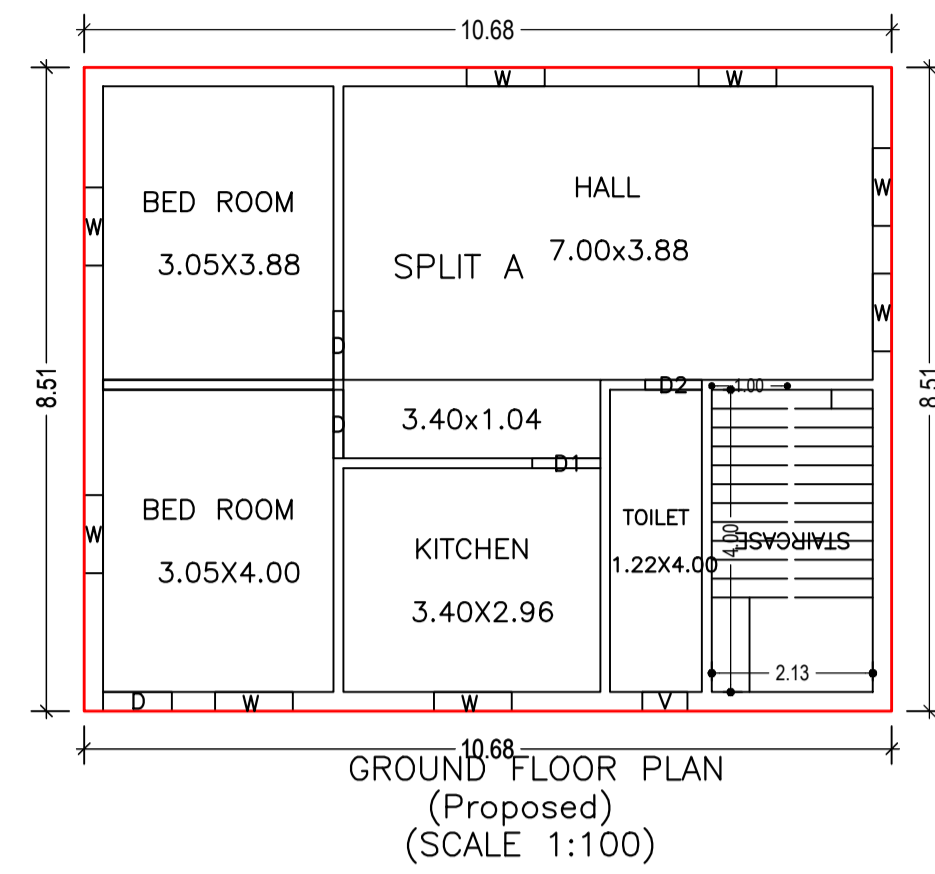
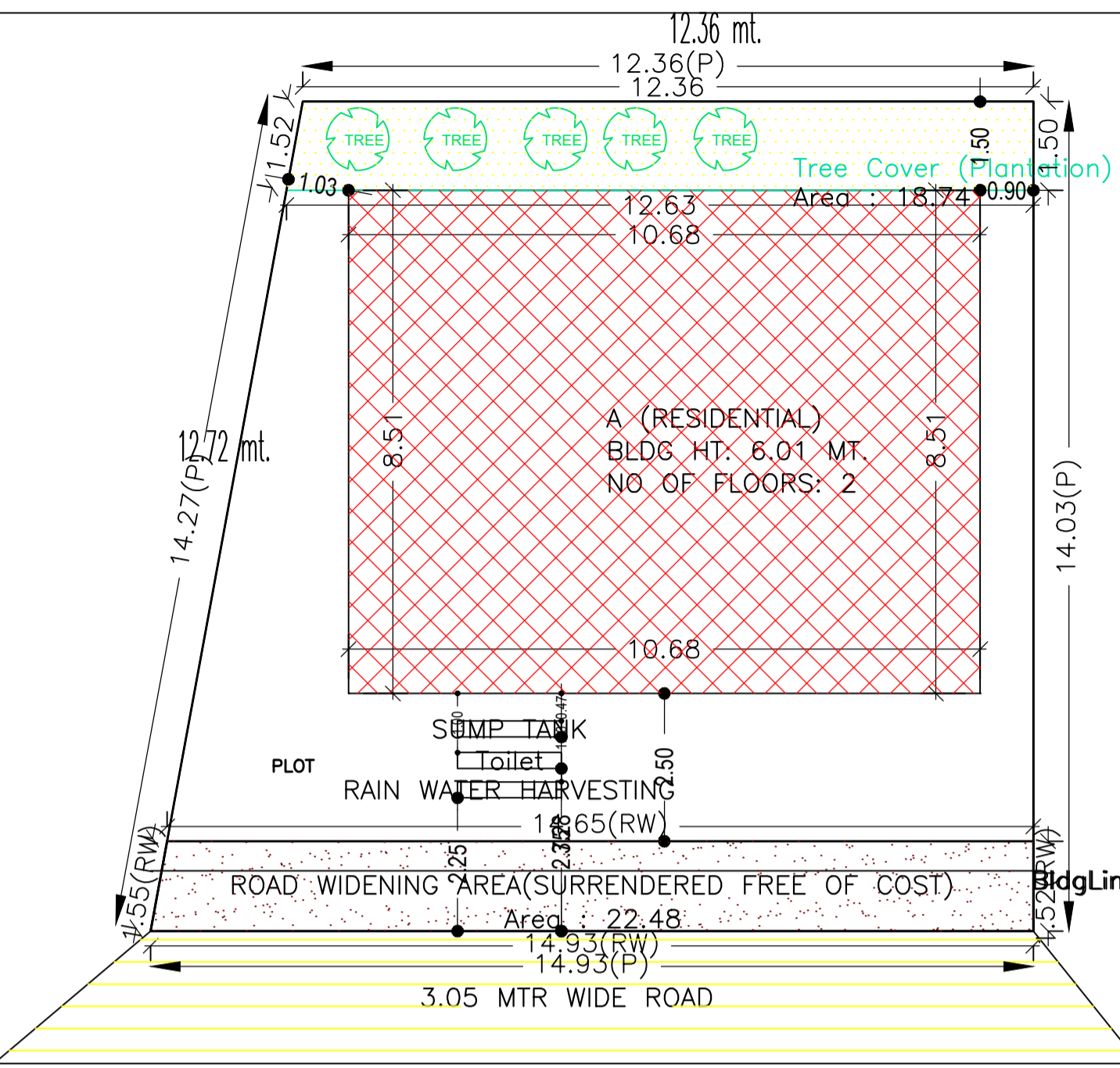
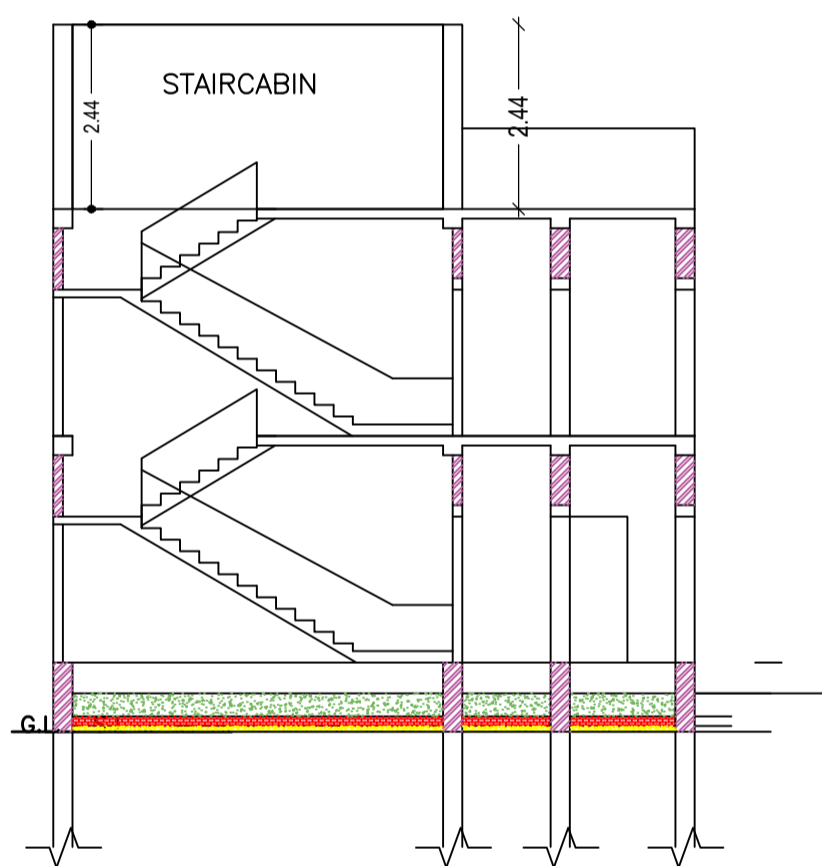

**CROSS SECTION (B)**

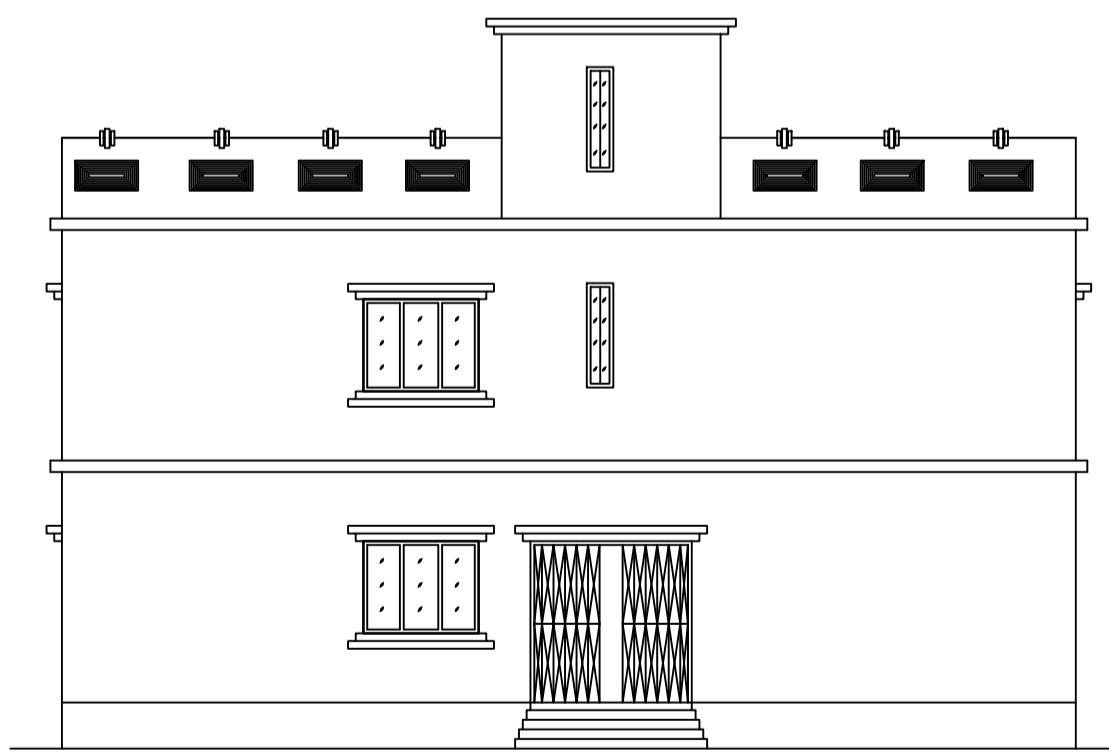
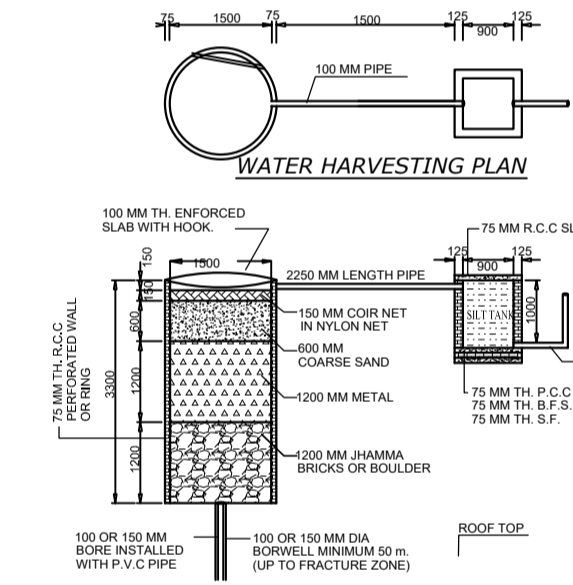
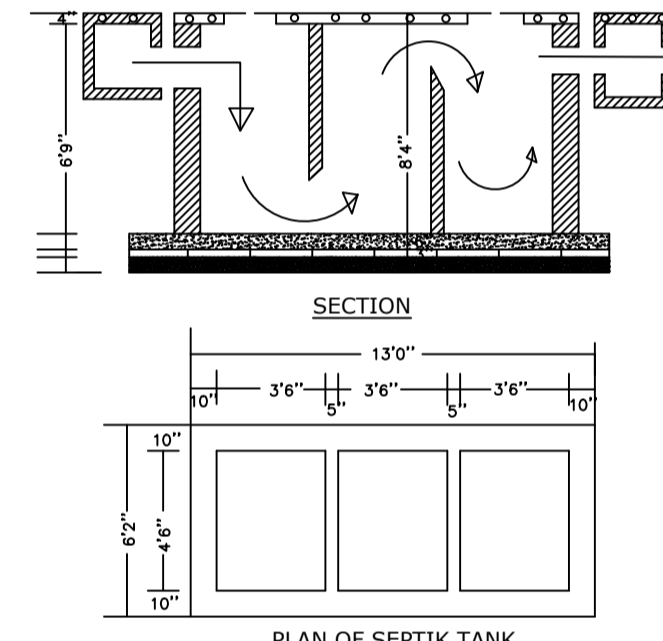
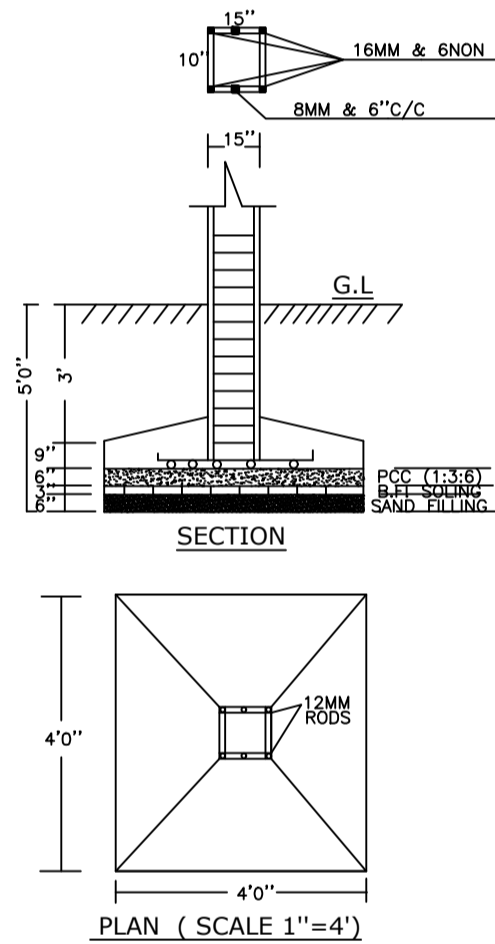
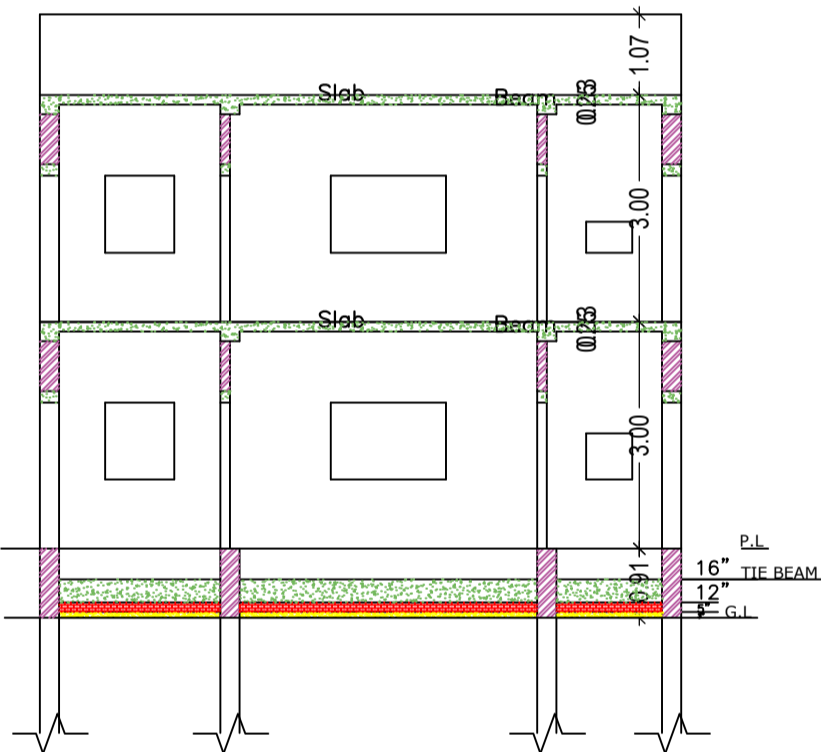

**CROSS ELEVATION**

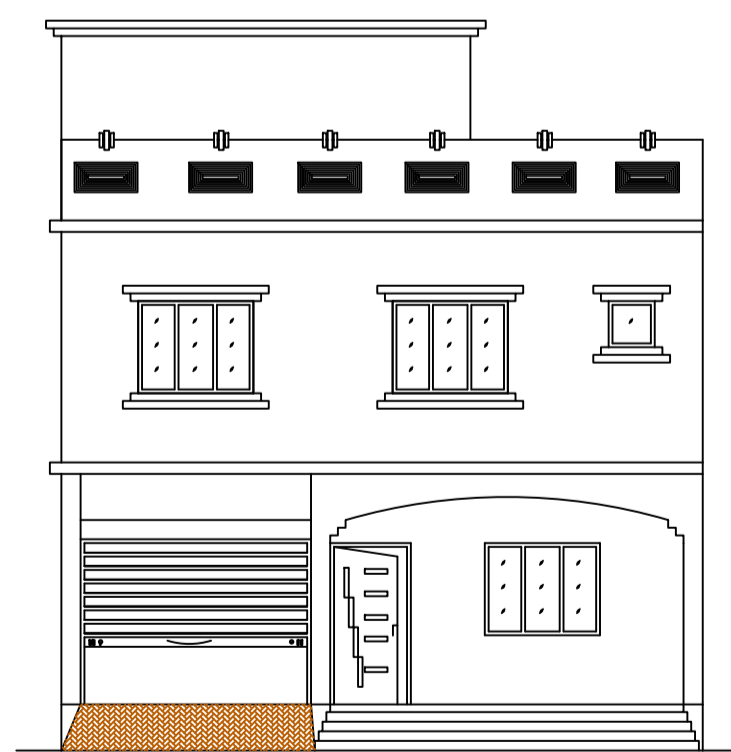

**FRONT ELEVATION**

**SCHEDULE OF DOOR:**

BUILDING NAME	NAME	LENGTH	HEIGHT	NOS
A (RESIDENTIAL)	D2	0.75	2.10	02
A (RESIDENTIAL)	D1	0.90	2.10	02
A (RESIDENTIAL)	D	0.91	2.10	06

**SCHEDULE OF WINDOW/VENTILATION:**

BUILDING NAME	NAME	LENGTH	HEIGHT	NOS
A (RESIDENTIAL)	V	0.60	0.90	02
A (RESIDENTIAL)	W	1.03	1.20	16

**UnitBUA Table for Building :A (RESIDENTIAL)**

FLOOR	Name	UnitBUA Type	UnitBUA Area	Carpet Area	No. of Rooms	No. of Tenement
GROUND FLOOR PLAN	SPLIT A	FLAT	161.61	160.82	5	1
FIRST FLOOR PLAN	SPLIT A	FLAT	0.00	0.00	5	0
Total:	-	-	161.61	160.82	10	1

**Building :A (RESIDENTIAL)**

Floor Name	Total Built Up Area (Sq.mt.)	Proposed FAR Area (Sq.mt.) Resi.	Total FAR Area (Sq.mt.)	Total Consumed Additional FAR Area (Sq.mt.)	Tnmt (No.)
Ground Floor	90.93	90.93	90.93	90.93	01
First Floor	90.93	90.93	90.93	90.93	00
Terrace Floor	0.00	0.00	0.00	0.00	00
Total:	181.86	181.86	181.86	181.86	01
Total Number of Same Buildings	1				
Total:	181.86	181.86	181.86	181.86	01

**COLOR INDEX**

PLOT BOUNDARY	Black
ABUTTING ROAD	Green
PROPOSED CONSTRUCTION	Red
COMMON PLOT	Yellow
ROAD WIDENING AREA	Blue
EXISTING (To be retained)	Orange
EXISTING (To be demolished)	Light Blue

**Buildingwise Floor FAR Details**

Floor Name	Building Name A (RESIDENTIAL)		Total	
	Proposed Built Up Area (Sq.mt.)	Proposed FAR Area (Sq.mt.)	Total Proposed Built Up Area (Sq.mt.)	Total FAR Area (Sq.mt.)
Ground Floor	90.93	90.93	90.93	90.93
First Floor	90.93	90.93	90.93	90.93
Terrace Floor	0.00	0.00	0.00	0.00
Total:	181.86	181.86	181.86	181.86

**Building USE/SUBUSE Details**

Building Name	Building Use	Building SubUse	Building Structure
A (RESIDENTIAL)	Residential	Bungalow/ Dwelling / Non Apartment	Non-Highrise

**FAR & Tenement Details (Table 4c-1)**

Building	No. of Same Bldg	Total Built Up Area (Sq.mt.)	Proposed FAR Area (Sq.mt.) Resi.	Total FAR Area (Sq.mt.)	Total Consumed Additional FAR Area (Sq.mt.)	Tnmt (No.)
A (RESIDENTIAL)	1	181.86	181.86	181.86	181.86	01
Grand Total :	1	181.86	181.86	181.86	181.86	01

LTP NAME AND SIGNATURE	STRUCTURAL ENG'S NAME AND SIGNATURE	BUILDER NAME AND SIGNATURE	DIGITAL SIGNATURE
RANJIT KUMAR MNNP/ENG/0001/2016			