

FAR & Tenement Details (Table 4c-1)

Building	No. of Same Bldg	Total Built Up Area (Sq.mt.)	Deductions (Area in Sq.mt.)		Proposed FAR Area (Sq.mt.)	Add Area In FAR (Sq.mt.)	Total FAR Area (Sq.mt.)	Total Consumed Additional FAR Area (Sq.mt.)	Trnmt (No.)
			Parking	Resi.					
A (BUILDING)	1	107.59	46.02	53.80	7.77	61.57	61.57	01	
Grand Total :	1	107.59	46.02	53.80	7.77	61.57	61.57	01	

Proposal Basic Information

Proposal File No.	MNNP/EP/0005/W18/2023
Owner Name	Anugrah Narayan Tiwari
Khata No	183
Plot No	677
Village Name	Rodma
Use	Residential
SubUse	Bungalow/ Dwelling / Non Apartment

AREA STATEMENT

AREA DETAILS:		SQ.MT.
AREA OF PLOT (Minimum)	(A)	104.63
Deduction for NetPlot Area		
Surrender Free of Cost		10.39
Total		10.39
NET AREA OF PLOT(Gross Plot Area - Deduction from Gross Plot area)	(A-Deductions)	94.23
Deduction for Balance Plot Area(from Gross Plot Area)		
Surrender Free of Cost		10.39
Common Plot		12.78
Total		23.17
BALANCE AREA OF PLOT(Net Plot Area - Recreational/Amenity space)	(A-Deductions)	81.45
PLOT AREA FOR COVERAGE(Net Plot Area)	(A-Deductions)	94.23
Plot Area for FAR (Net Plot Area + Road/Widening Area)	(A-Deductions)	104.63
COVERAGE CHECK		
Permissible Coverage area ( 70.00 % )		65.96
Proposed Coverage Area ( 57.09 % )		53.80
Total Prop. Coverage Area ( 57.09 % )		53.80
Balance coverage area ( 12.90 % )		12.16
FAR CHECK		
Perm. FAR Area ( 1.500 )		156.94
Total Perm. FAR area		156.94
Residential FAR		53.80
Proposed FAR Area		61.57
Total Proposed FAR Area		61.57
Consumed FAR (Factor)		0.59
Balance FAR Area		95.37
BUILT UP AREA CHECK		
Total Proposed BuiltUp Area		107.59
ARCHITECT (Regd)	RANJIT KUMAR	
ENGINEER (Regd)		
SUPERVISOR (Regd)		
OWNER (Regd)	Anugrah Narayan Tiwari	
DEVELOPMENT AUTHORITY	LOCAL BODY	

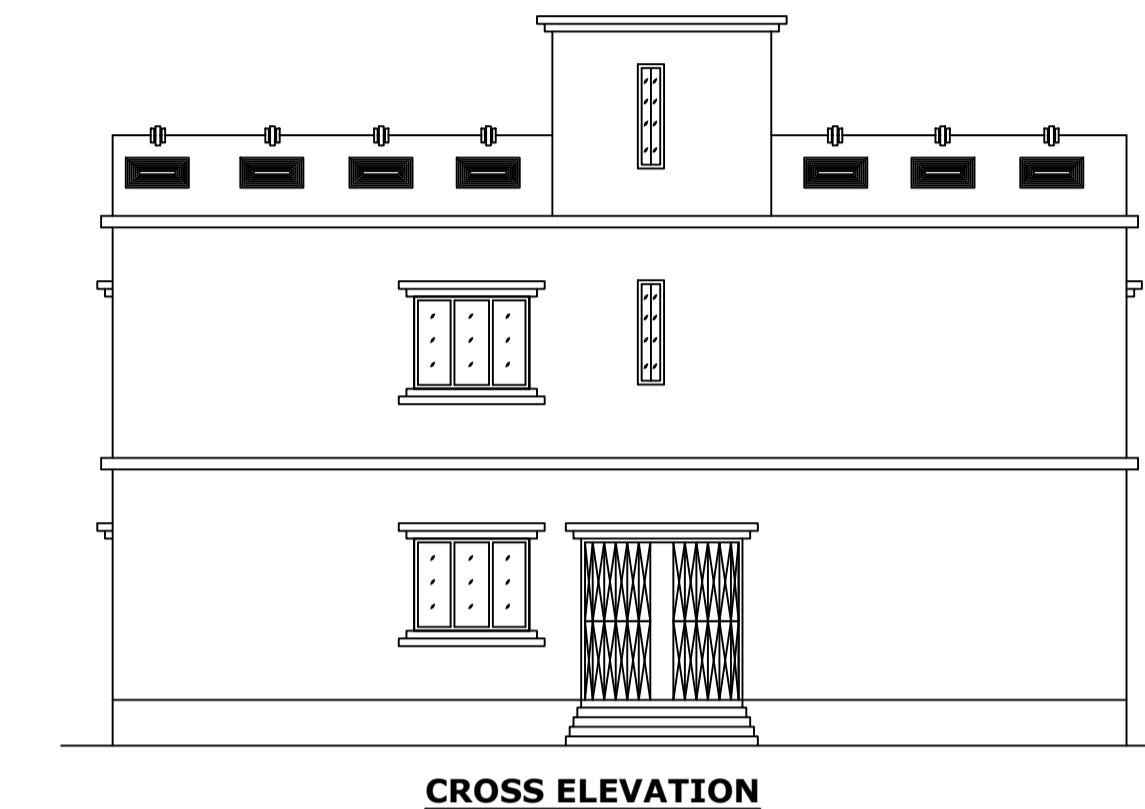

CROSS ELEVATION

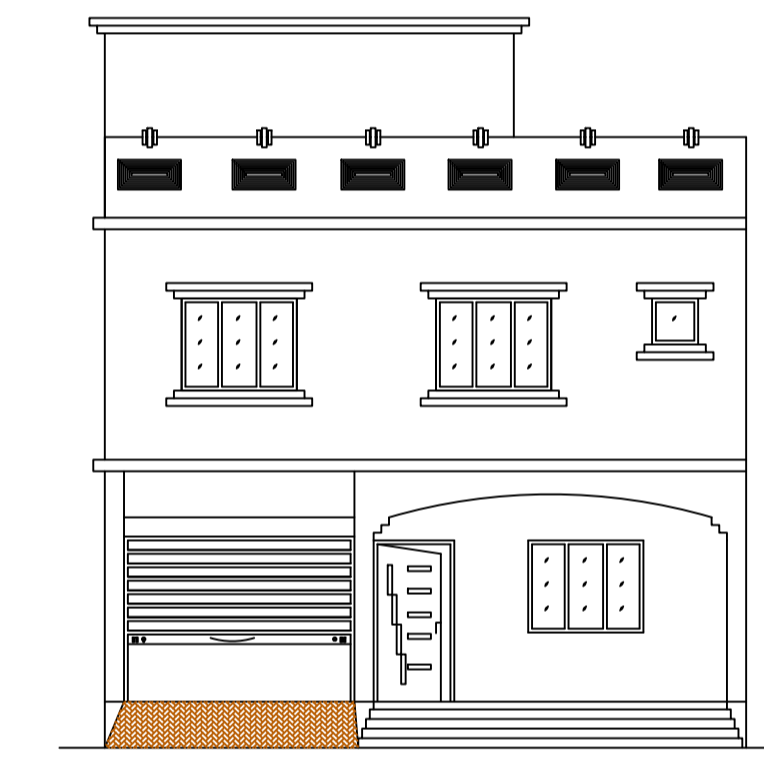

FRONT ELEVATION

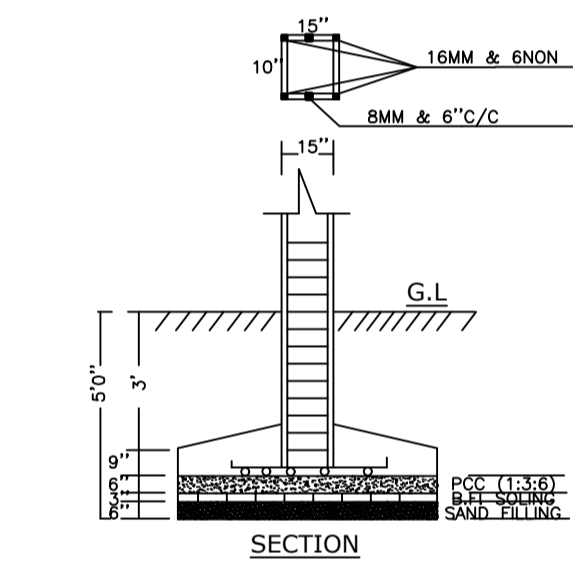

SECTION

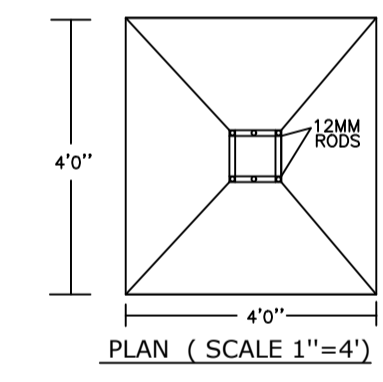

PLAN ( SCALE 1''=4'')

COLOR INDEX

PLOT BOUNDARY	Black
ABUTTING ROAD	Green
PROPOSED CONSTRUCTION	Red
COMMON PLOT	Yellow
ROAD WIDENING AREA	Blue
EXISTING (To be retained)	Orange
EXISTING (To be demolished)	White

Buildingwise Floor FAR Details

Floor Name	Building Name A (BUILDING)		Total	
	Proposed Built Up Area (Sq.mt.)	Proposed FAR Area (Sq.mt.)	Total Proposed Built Up Area (Sq.mt.)	Total FAR Area (Sq.mt.)
Ground Floor	53.79	7.77	53.79	7.77
First Floor	53.80	53.80	53.80	53.80
Terrace Floor	0.00	0.00	0.00	0.00
Total :	107.59	61.57	107.59	61.57

Building :A (BUILDING)

Floor Name	Total Built Up Area (Sq.mt.)	Deductions (Area in Sq.mt.)	Proposed FAR Area (Sq.mt.)	Add Area In FAR (Sq.mt.)	Total FAR Area (Sq.mt.)	Total Consumed Additional FAR Area (Sq.mt.)	Trnmt (No.)
Ground Floor	53.79	46.02	0.00	7.77	7.77	7.77	00
First Floor	53.80	0.00	53.80	0.00	53.80	53.80	01
Terrace Floor	0.00	0.00	0.00	0.00	0.00	0.00	00
Total :	107.59	46.02	53.80	7.77	61.57	61.57	01
Total Number of Same Buildings	1						
Total :	107.59	46.02	53.80	7.77	61.57	61.57	01

SCHEDULE OF DOOR:

BUILDING NAME	NAME	LENGTH	HEIGHT	NOS
A (BUILDING)	D2	0.75	2.10	01
A (BUILDING)	D1	0.75	2.10	01
A (BUILDING)	D	0.75	2.10	02
A (BUILDING)	D	0.79	2.10	01

SCHEDULE OF WINDOW/VENTILATION:

BUILDING NAME	NAME	LENGTH	HEIGHT	NOS
A (BUILDING)	V	0.61	0.60	01
A (BUILDING)	W	1.20	1.20	06

UnitBUA Table for Building :A (BUILDING)

FLOOR	Name	UnitBUA Type	UnitBUA Area	Carpet Area	No. of Rooms	No. of Tenement
FIRST FLOOR PLAN	SPLIT B	FLAT	44.52	44.15	5	1
Total:	-	-	44.52	44.15	5	1

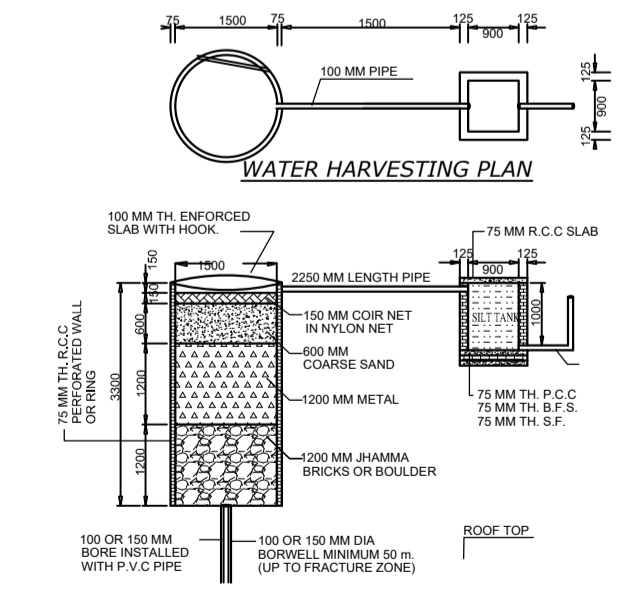

WATER HARVESTING PLAN

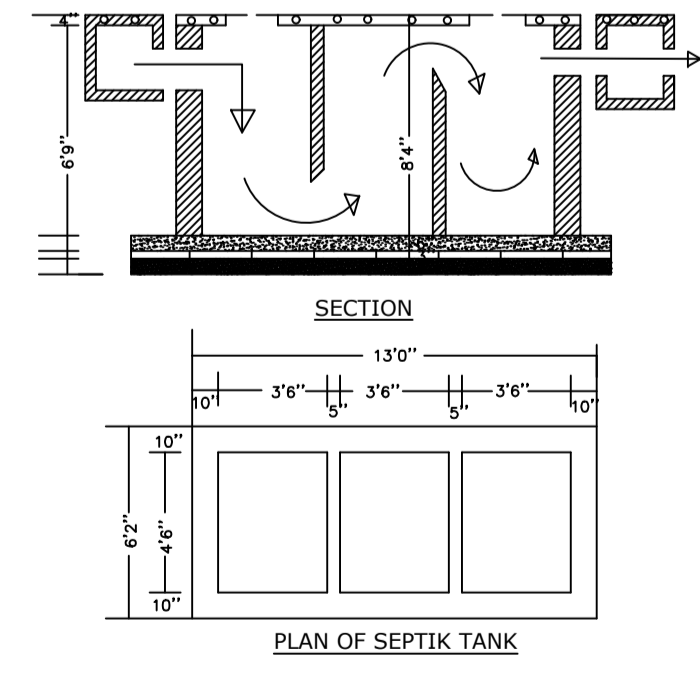

PLAN OF SEPTIC TANK

Building USE/SUBUSE Details

Building Name	Building Use	Building SubUse	Building Structure
A (BUILDING)	Residential	Bungalow/ Dwelling / Non Apartment	Non-Highrise

LTP NAME AND SIGNATURE	STRUCTURAL ENG'S NAME AND SIGNATURE	BUILDER NAME AND SIGNATURE	DIGITAL SIGNATURE
RANJIT KUMAR MNNP/ENG/0001/2016			