

SITE PLAN

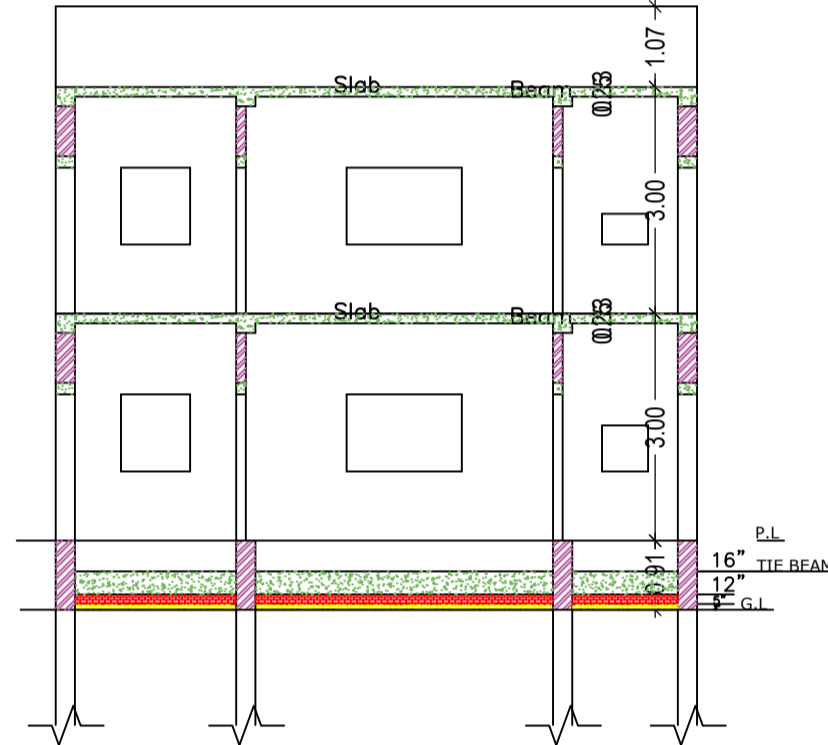
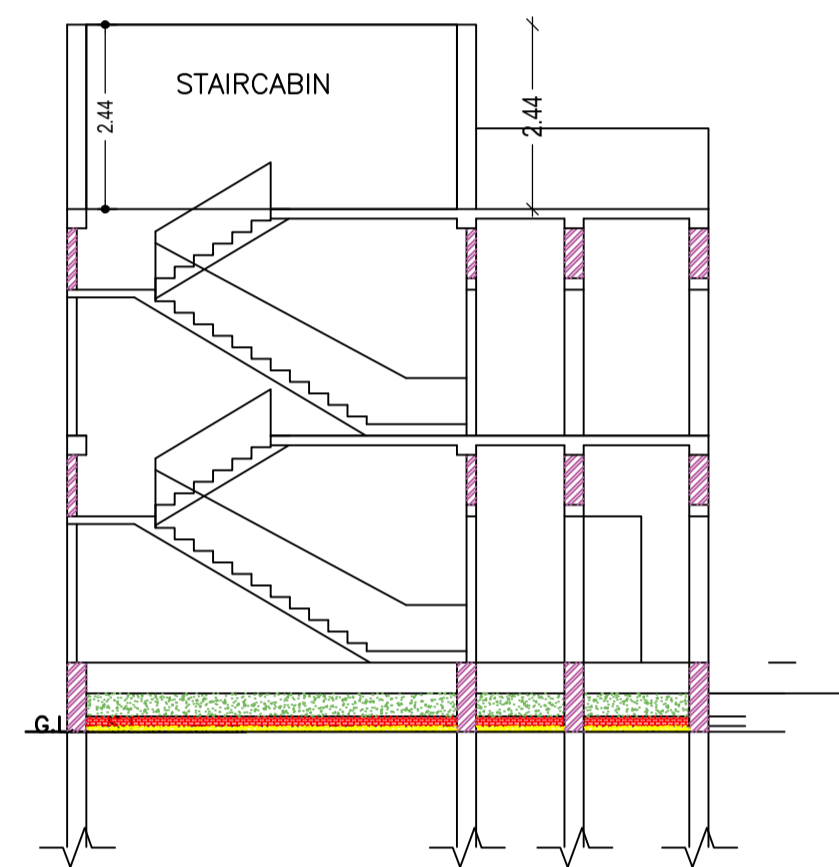
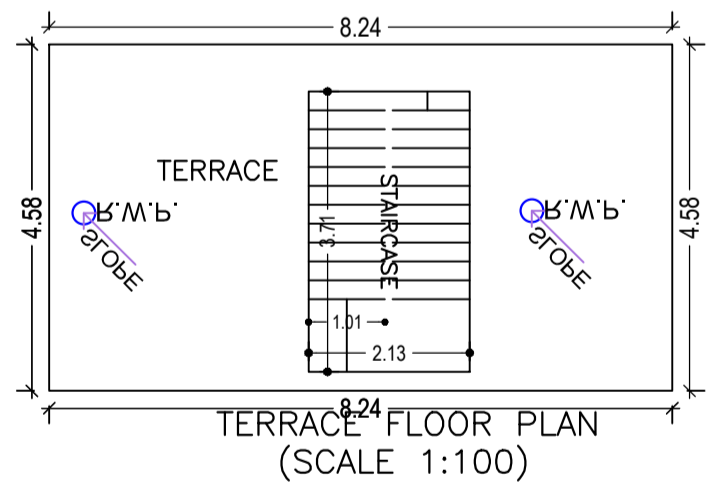
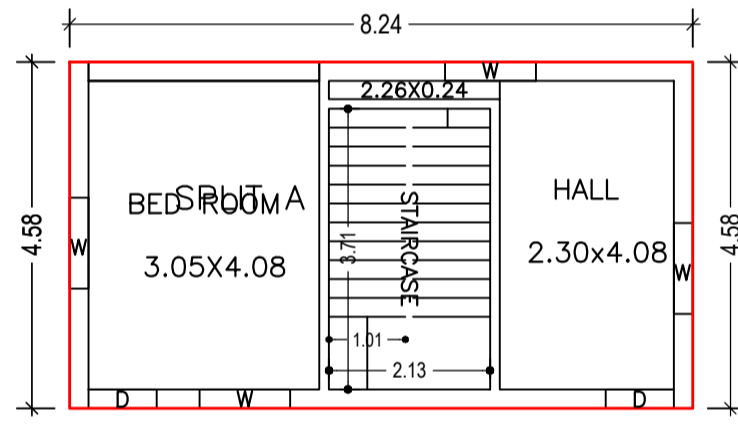
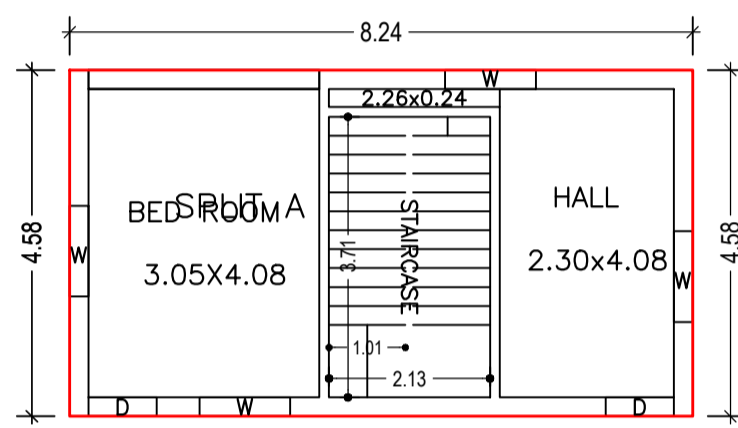

FAR & Tenement Details (Table 4c-1)

Building	No. of Same Bldg	Total Built Up Area (Sq.mt.)	Proposed FAR Area (Sq.mt.) Resi.	Total FAR Area (Sq.mt.)	Total Consumed Additional FAR Area (Sq.mt.)	Tnmt (No.)
A (RESIDENTIAL)	1	75.48	75.48	75.48	75.48	01
Grand Total :	1	75.48	75.48	75.48	75.48	01

Proposal Basic Information

Proposal File No.	MNNP/EP/0012/W17/2023
Owner Name	Puja Kumari
Khata No	272
Plot No	1544
Village Name	Redma
Use	Residential
SubUse	Bungalow/ Dwelling / Non Apartment

AREA STATEMENT	VERSION NO. : 1.0.65
MEDININAGAR MUNICIPAL CORPORATION	VERSION DATE: 16/10/2020
PROJECT DETAIL:	
Region: JHARKHAND URBAN LOCAL BODIES	Plot Use: Residential
District: PALAMU	Plot SubUse: Bungalow/ Dwelling / Non Apartment
Authority: MEDININAGAR MUNICIPAL CORPORATION	PlotNearby/ReligiousStructure: NA
Inward No: MNNP/EP/0012/W17/2023	Plot/SubPlot No: 1544
Application Type: General Proposal	North: -
Project Type: Building Permission	South: -
Nature of Development: New	East: -
Location of Development Area: Old Area	West: -
AREA DETAILS:	SQ.MT.
AREA OF PLOT (Minimum)	(A) 161.40
Deduction for NetPlot Area	
Surrender Free of Cost	27.02
Total	27.02
NET AREA OF PLOT (Gross Plot Area - Deduction from Gross Plot area)	(A-Deductions) 134.38
Deduction for Balance Plot Area (from Gross Plot Area)	
Surrender Free of Cost	27.02
Common Plot	13.86
Total	40.88
BALANCE AREA OF PLOT (Net Plot Area - Recreational/Amenity space)	(A-Deductions) 120.52
PLOT AREA FOR COVERAGE (Net Plot Area)	(A-Deductions) 134.38
Plot Area for FAR (Net Plot Area + Road/Widening Area)	(A-Deductions) 161.40
COVERAGE CHECK	
Permissible Coverage area ( 70.00 % )	94.07
Proposed Coverage Area ( 28.08 % )	37.74
Total Prop. Coverage Area ( 28.08 % )	37.74
Balance coverage area ( 41.92 % )	56.33
FAR CHECK	
Perm. FAR Area ( 1.200 )	193.68
Total Perm. FAR area	193.68
Residential FAR	75.48
Proposed FAR Area	75.48
Total Proposed FAR Area	75.48
Consumed FAR (Factor)	0.47
Balance FAR Area	118.20
BUILT UP AREA CHECK	
Total Proposed BuiltUp Area	75.48
ARCHITECT (Regd)	RANJIT KUMAR
ENGINEER (Regd)	
SUPERVISOR (Regd)	
OWNER (Regd)	Puja Kumari
DEVELOPMENT AUTHORITY	LOCAL BODY

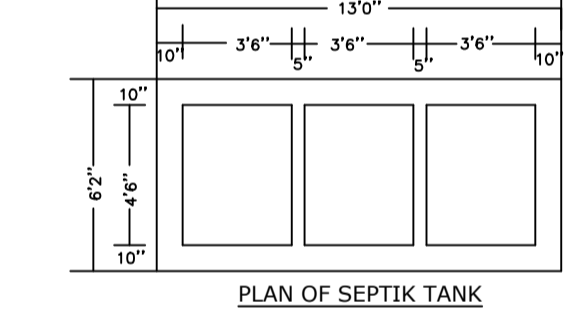
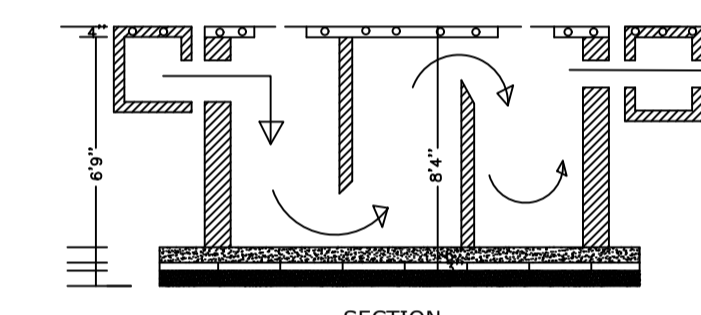
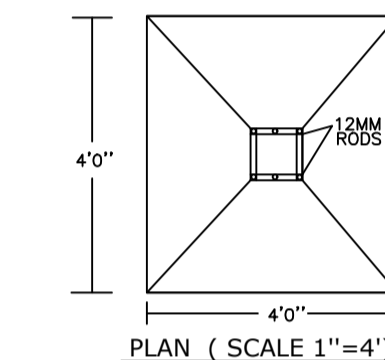
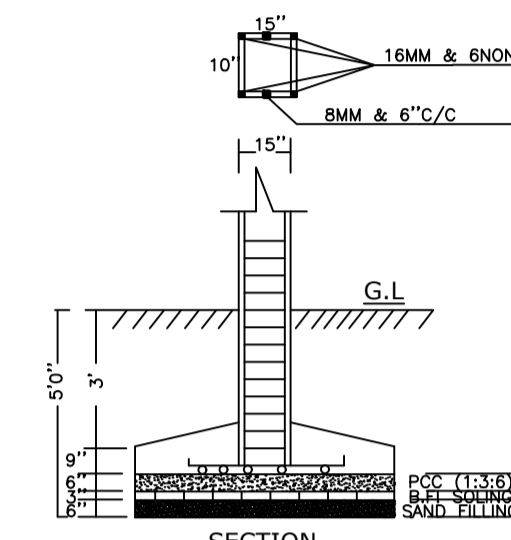

COLOR INDEX	
PLOT BOUNDARY	[Red Line]
ABUTTING ROAD	[Green Line]
PROPOSED CONSTRUCTION	[Yellow Line]
COMMON PLOT	[Blue Line]
ROAD WIDENING AREA	[Orange Line]
EXISTING (To be retained)	[Green Line]
EXISTING (To be demolished)	[Red Line]

Building :A (RESIDENTIAL)

Floor Name	Total Built Up Area (Sq.mt.)	Proposed FAR Area (Sq.mt.) Resi.	Total FAR Area (Sq.mt.)	Total Consumed Additional FAR Area (Sq.mt.)	Tnmt (No.)
Ground Floor	37.74	37.74	37.74	37.74	01
First Floor	37.74	37.74	37.74	37.74	00
Terrace Floor	0.00	0.00	0.00	0.00	00
Total :	75.48	75.48	75.48	75.48	01
Total Number of Same Buildings	1				
Total :	75.48	75.48	75.48	75.48	01

SCHEDULE OF DOOR:

BUILDING NAME	NAME	LENGTH	HEIGHT	NOS
A (RESIDENTIAL)	D	0.90	2.10	04

SCHEDULE OF WINDOW/VENTILATION:

BUILDING NAME	NAME	LENGTH	HEIGHT	NOS
A (RESIDENTIAL)	W	1.20	1.20	08

UnitBUA Table for Building :A (RESIDENTIAL)

FLOOR	Name	UnitBUA Type	UnitBUA Area	Carpet Area	No. of Rooms	No. of Tenement
GROUND FLOOR PLAN	SPLIT A	FLAT	58.61	57.08	2	1
FIRST FLOOR PLAN	SPLIT A	FLAT	0.00	0.00	2	0
Total:	-	-	58.61	57.08	4	1

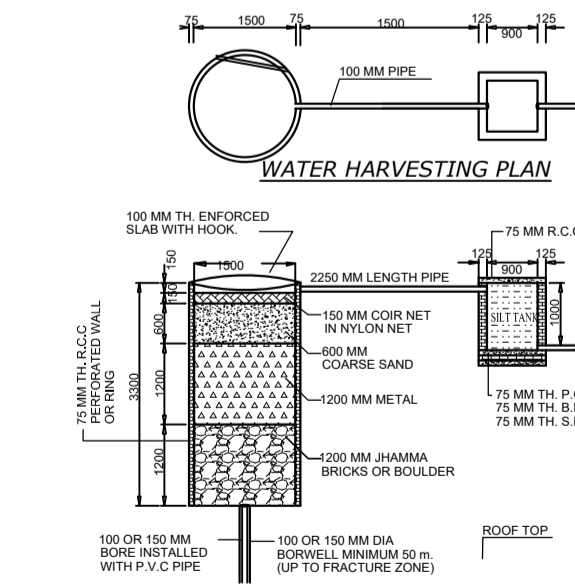

Buildingwise Floor FAR Details

Floor Name	Building Name A (RESIDENTIAL)		Total	
	Proposed Built Up Area (Sq.mt.)	Proposed FAR Area (Sq.mt.)	Total Proposed Built Up Area (Sq.mt.)	Total FAR Area (Sq.mt.)
Ground Floor	37.74	37.74	37.74	37.74
First Floor	37.74	37.74	37.74	37.74
Terrace Floor	0.00	0.00	0.00	0.00
Total :	75.48	75.48	75.48	75.48

Building USE/SUBUSE Details

Building Name	Building Use	Building SubUse	Building Structure
A (RESIDENTIAL)	Residential	Bungalow/ Dwelling / Non Apartment	Non-Highrise

LTP NAME AND SIGNATURE	STRUCTURAL ENG'S NAME AND SIGNATURE	BUILDER NAME AND SIGNATURE	DIGITAL SIGNATURE
RANJIT KUMAR MNNP/ENG/0001/2016			