

Proposal Basic Information

Proposal File No.	MNNP/BP/0011/W/17/2023
Owner Name	Sabita Kumari
Khata No	272
Plot No	1544
Village Name	Rodma
Use	Residential
SubUse	Bungalow/ Dwelling / Non Apartment

FAR & Tenement Details (Table 4c-1)

Building	No. of Same Bldg	Total Built Up Area (Sq.mt.)	Proposed FAR Area (Sq.mt.) Resi.	Total FAR Area (Sq.mt.)	Total Consumed Additional FAR Area (Sq.mt.)	Tnmt (No.)
A (RESIDENTIAL)	1	140.34	140.34	140.34	140.34	01
Grand Total :	1	140.34	140.34	140.34	140.34	01

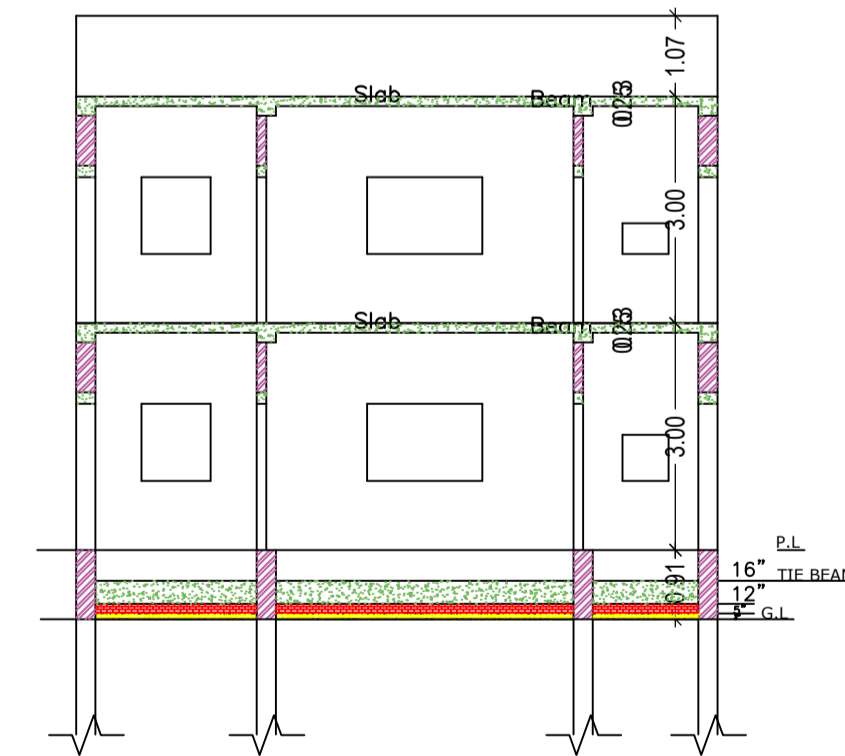
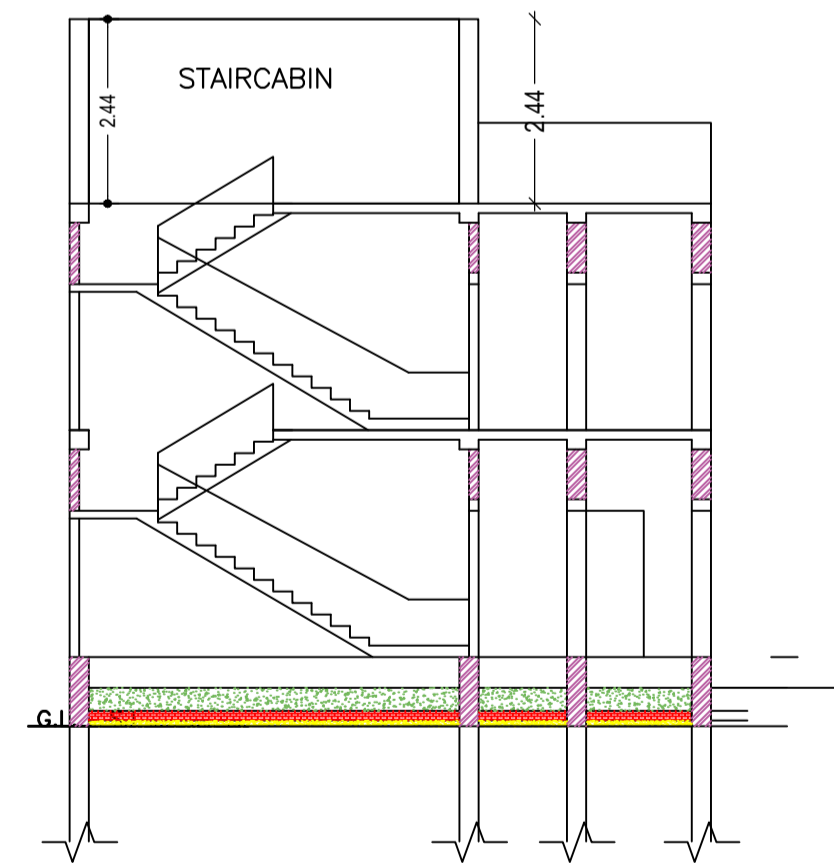
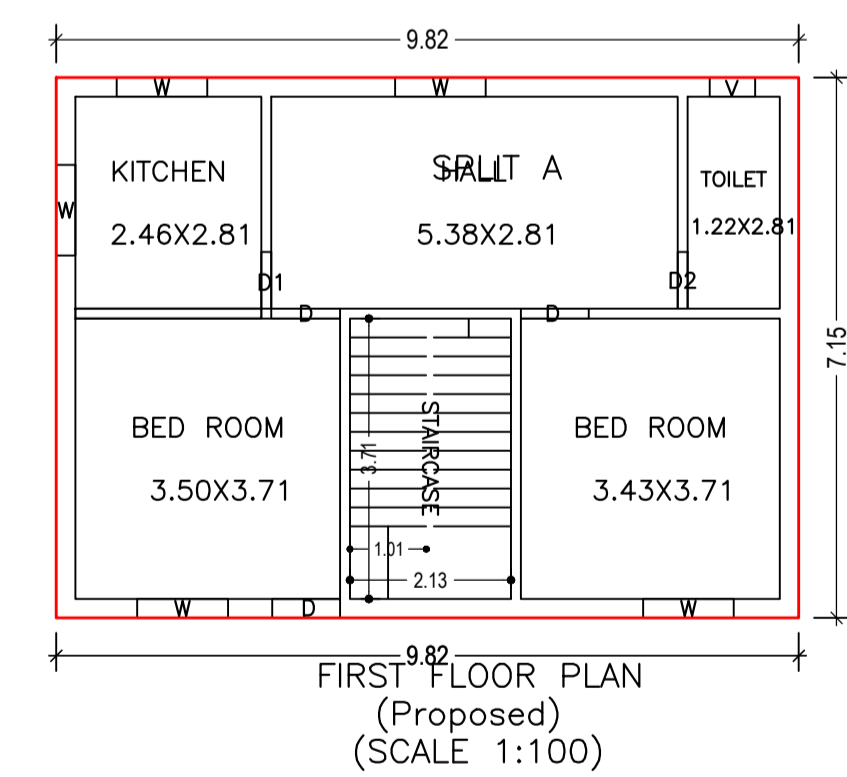
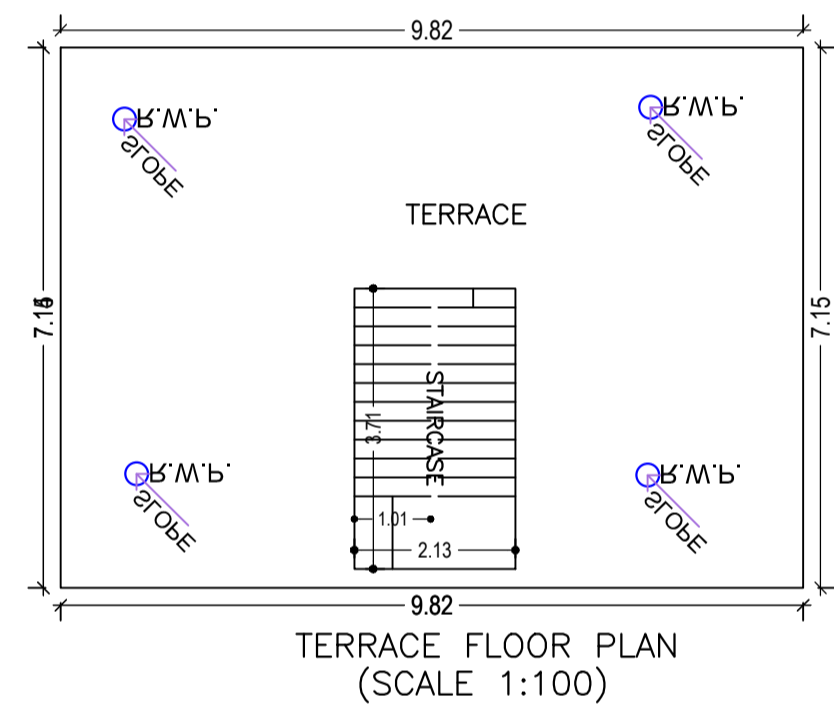
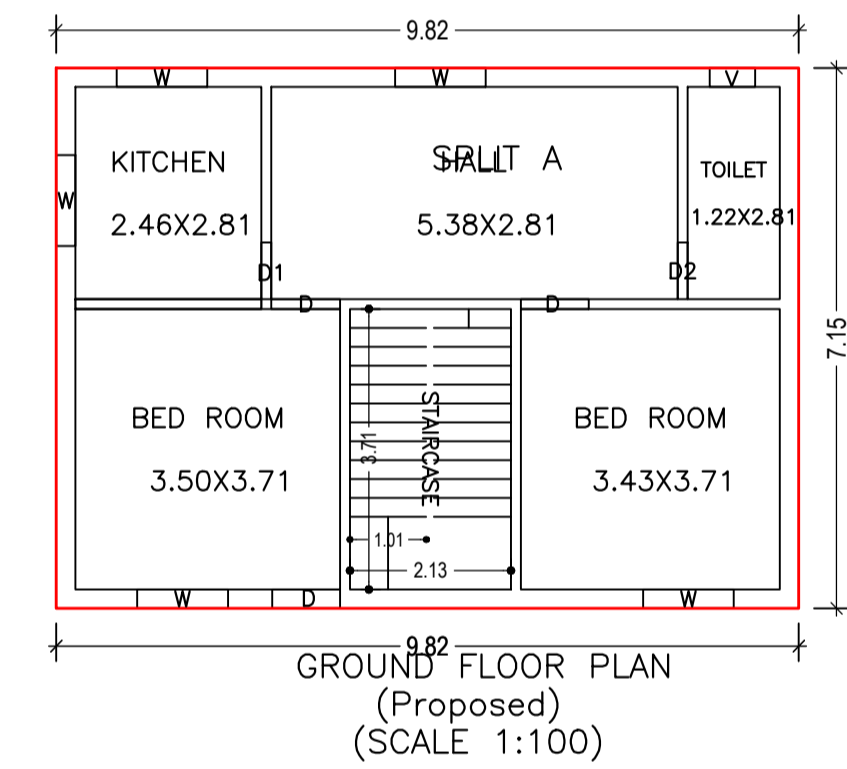
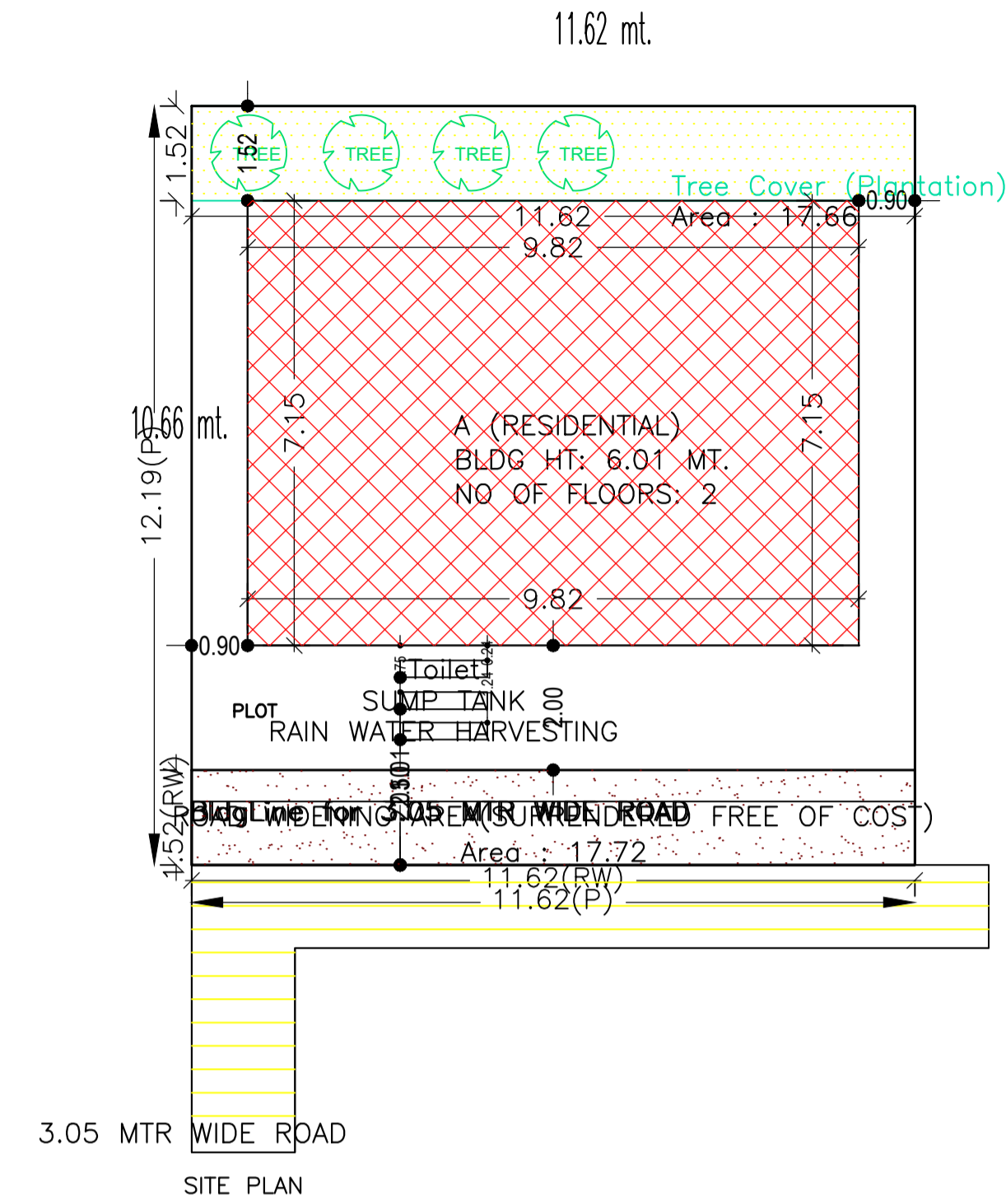

Floor Name	Total Built Up Area (Sq.mt.)	Proposed FAR Area (Sq.mt.) Resi.	Total FAR Area (Sq.mt.)	Total Consumed Additional FAR Area (Sq.mt.)	Tnmt (No.)
Ground Floor	70.17	70.17	70.17	70.17	01
First Floor	70.17	70.17	70.17	70.17	00
Terrace Floor	0.00	0.00	0.00	0.00	00
Total :	140.34	140.34	140.34	140.34	01
Total Number of Same Buildings	1				
Total :	140.34	140.34	140.34	140.34	01

SCHEDULE OF DOOR:

BUILDING NAME	NAME	LENGTH	HEIGHT	NOS
A (RESIDENTIAL)	D1	0.75	2.10	02
A (RESIDENTIAL)	D2	0.75	2.10	02
A (RESIDENTIAL)	D	0.90	2.10	04
A (RESIDENTIAL)	D	0.91	2.10	02

SCHEDULE OF WINDOW/VENTILATION:

BUILDING NAME	NAME	LENGTH	HEIGHT	NOS
A (RESIDENTIAL)	V	0.60	0.90	02
A (RESIDENTIAL)	W	1.20	1.20	10

UnitBUA Table for Building :A (RESIDENTIAL)

FLOOR	Name	UnitBUA Type	UnitBUA Area	Carpet Area	No. of Rooms	No. of Tenement
FIRST FLOOR PLAN	SPLIT A	FLAT	0.00	0.00	5	0
GROUND FLOOR PLAN	SPLIT A	FLAT	123.47	122.83	5	1
Total:	-	-	123.47	122.83	10	1

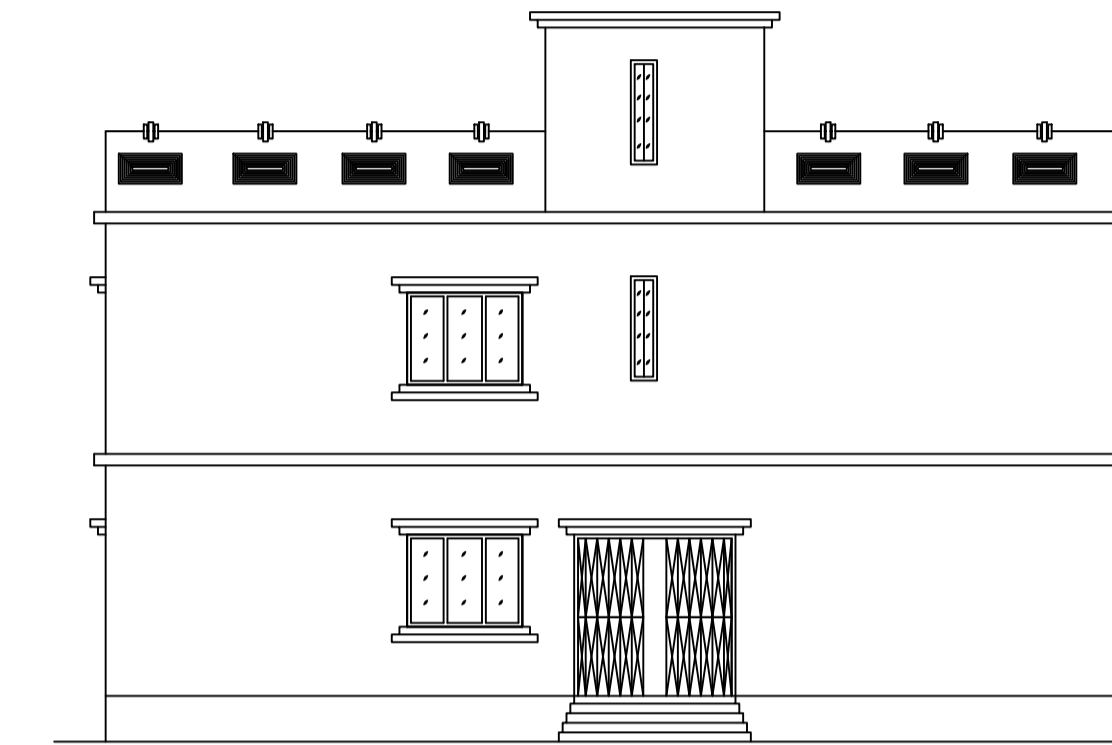

CROSS ELEVATION

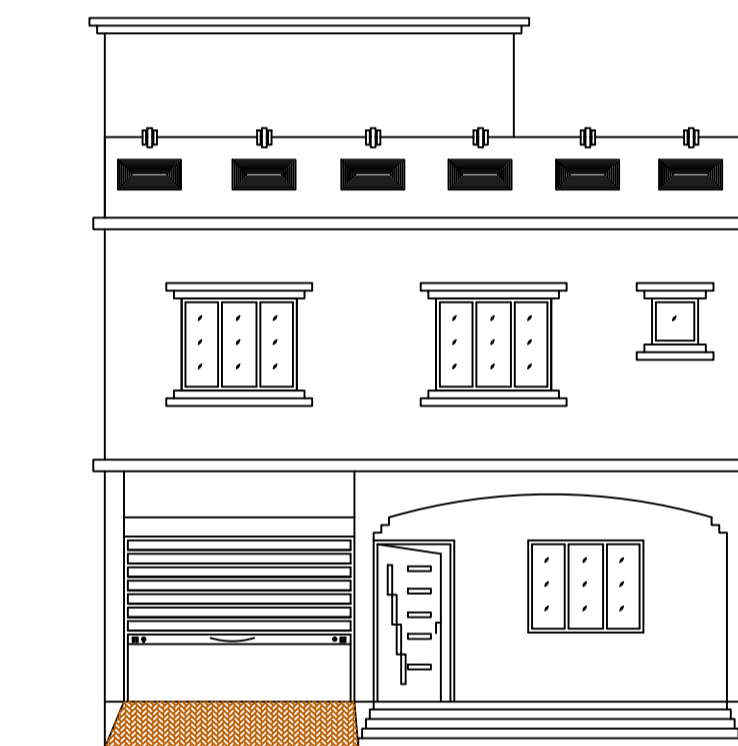

FRONT ELEVATION

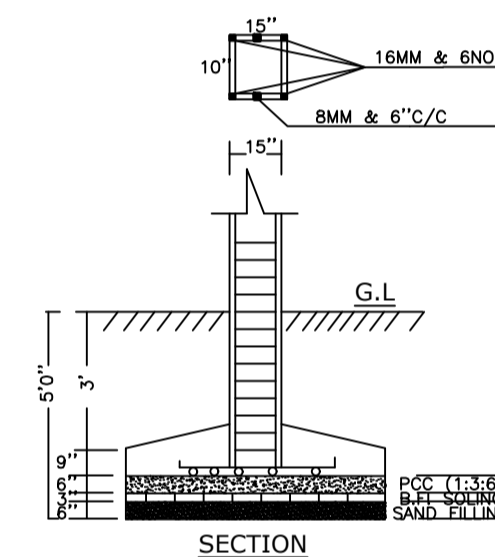

SECTION

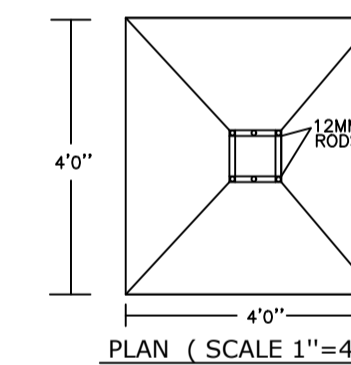

PLAN (SCALE 1:1=4')

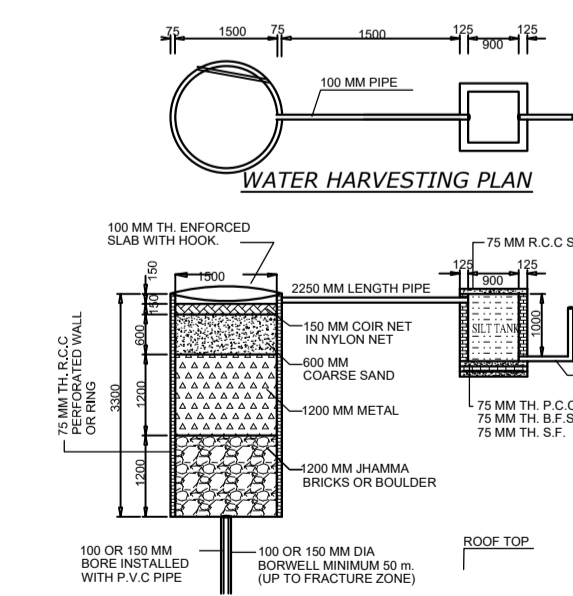

WATER HARVESTING PLAN

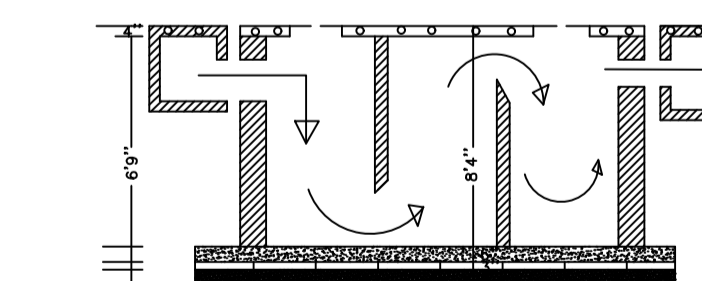

SECTION

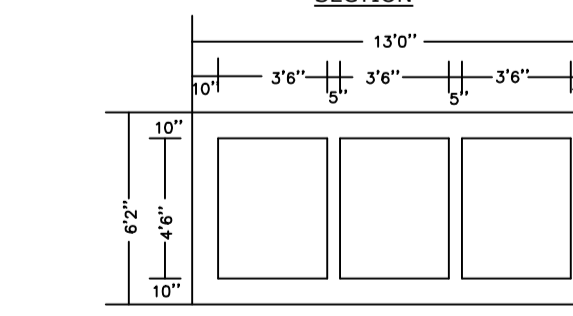

PLAN OF SEPTIK TANK

AREA STATEMENT	VERSION NO. : 1.0.65	SQ.MT.
MEDININAGAR MUNICIPAL CORPORATION	VERSION DATE: 16/10/2020	
PROJECT DETAIL:		
Region: JHARKHAND URBAN LOCAL BODIES	Plot Use: Residential	
District: PALAMU	Plot SubUse: Bungalow/ Dwelling / Non Apartment	
Authority: MEDININAGAR MUNICIPAL CORPORATION	PlotNearbyReligiousStructure: NA	
Inward No: MNNP/BP/0011/W/17/2023	Plot/SubPlot No: 1544	
Application Type: General Proposal	North: -	
Project Type: Building Permission	South: -	
Nature of Development: New	East: -	
Location of Development Area: Old Area	West: -	
AREA DETAILS:		
AREA OF PLOT (Minimum)	(A)	141.20
Deduction for NetPlot Area		
Surrender Free of Cost		17.72
Total		17.72
NET AREA OF PLOT(Gross Plot Area - Deduction from Gross Plot area)	(A-Deductions)	123.48
Deduction for Balance Plot Area(from Gross Plot Area)		
Surrender Free of Cost		17.72
Common Plot		17.66
Total		35.39
BALANCE AREA OF PLOT(Net Plot Area - Recreational/Amenity space)	(A-Deductions)	105.81
PLOT AREA FOR COVERAGE(Net Plot Area)	(A-Deductions)	123.48
Plot Area for FAR (Net Plot Area + Road Widening Area)	(A-Deductions)	141.20
COVERAGE CHECK		
Permissible Coverage area (70.00 %)		86.44
Proposed Coverage Area (56.83 %)		70.17
Total Prop. Coverage Area (56.83 %)		70.17
Balance coverage area (13.18 %)		16.27
FAR CHECK		
Perm. FAR Area (1.200)		169.44
Total Perm. FAR area		169.44
Residential FAR		140.34
Proposed FAR Area		140.34
Total Proposed FAR Area		140.34
Consumed FAR (Factor)		0.99
Balance FAR Area		29.10
BUILT UP AREA CHECK		
Total Proposed BuiltUp Area		140.34
ARCHITECT (Regd)	RANJIT KUMAR	
ENGINEER (Regd)		
SUPERVISOR (Regd)		
OWNER (Regd)	Sabita Kumari	
DEVELOPMENT AUTHORITY	LOCAL BODY	

COLOR INDEX	
PLOT BOUNDARY	Black
ABUTTING ROAD	Green
PROPOSED CONSTRUCTION	Red
COMMON PLOT	Yellow
ROAD WIDENING AREA	Blue
EXISTING (To be retained)	Orange
EXISTING (To be demolished)	White

Buildingwise Floor FAR Details

Floor Name	Building Name A (RESIDENTIAL)		Total	
	Proposed Built Up Area (Sq.mt.)	Proposed FAR Area (Sq.mt.)	Total Proposed Built Up Area (Sq.mt.)	Total FAR Area (Sq.mt.)
Ground Floor	70.17	70.17	70.17	70.17
First Floor	70.17	70.17	70.17	70.17
Terrace Floor	0.00	0.00	0.00	0.00
Total :	140.34	140.34	140.34	140.34

Building USE/SUBUSE Details

Building Name	Building Use	Building SubUse	Building Structure
A (RESIDENTIAL)	Residential	Bungalow/ Dwelling / Non Apartment	Non-Highrise

LTP NAME AND SIGNATURE	STRUCTURAL ENG'S NAME AND SIGNATURE	BUILDER NAME AND SIGNATURE	DIGITAL SIGNATURE
RANJIT KUMAR MNNP/ENG/0001/2016			