

Proposal Basic Information	
Proposal File No.	MNNP/BP/0040/W03/2023
Owner Name	Anant Prasad Shrivastava
Khata No	44
Plot No	305/A
Village Name	Sudna
Use	Residential
SubUse	Bungalow/ Dwelling / Non Apartment

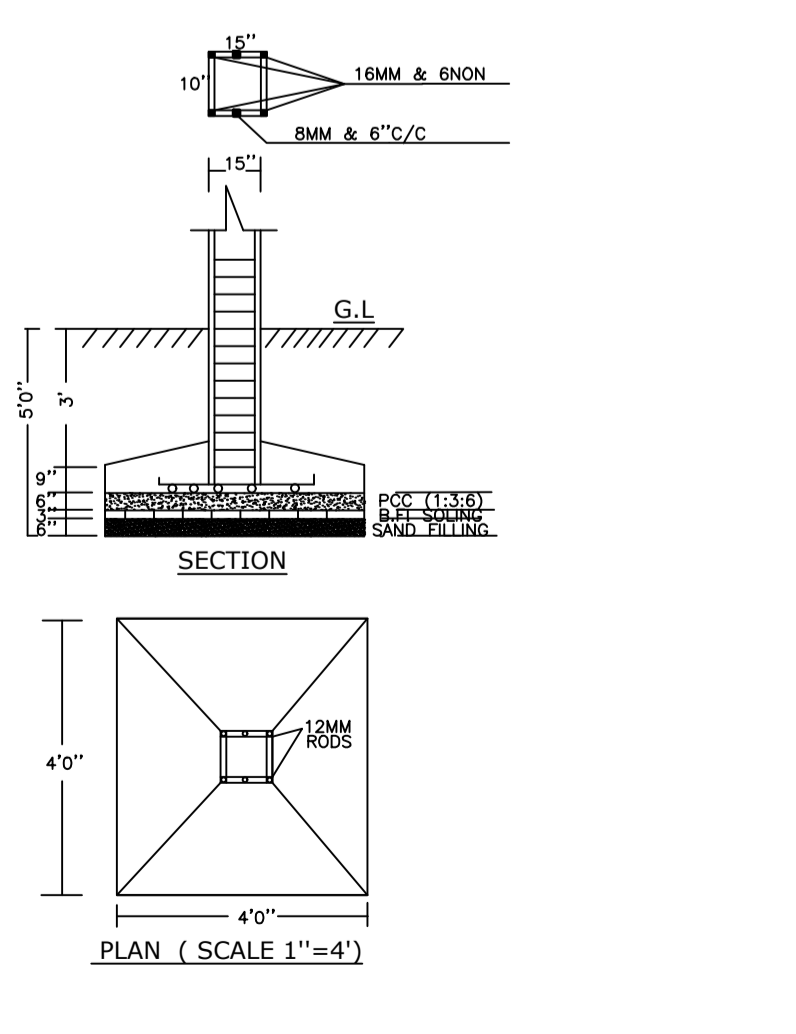
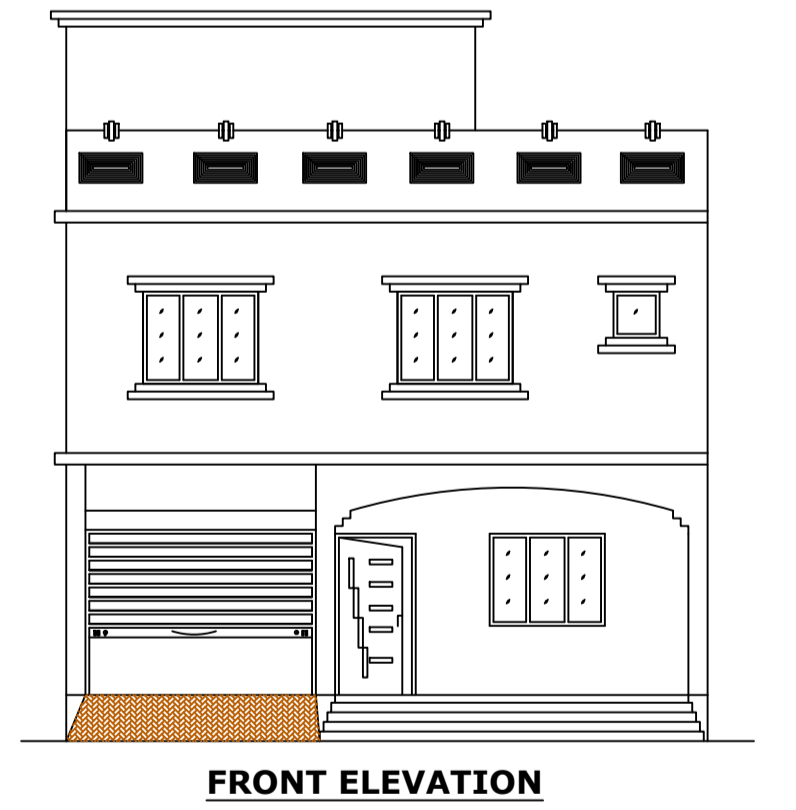
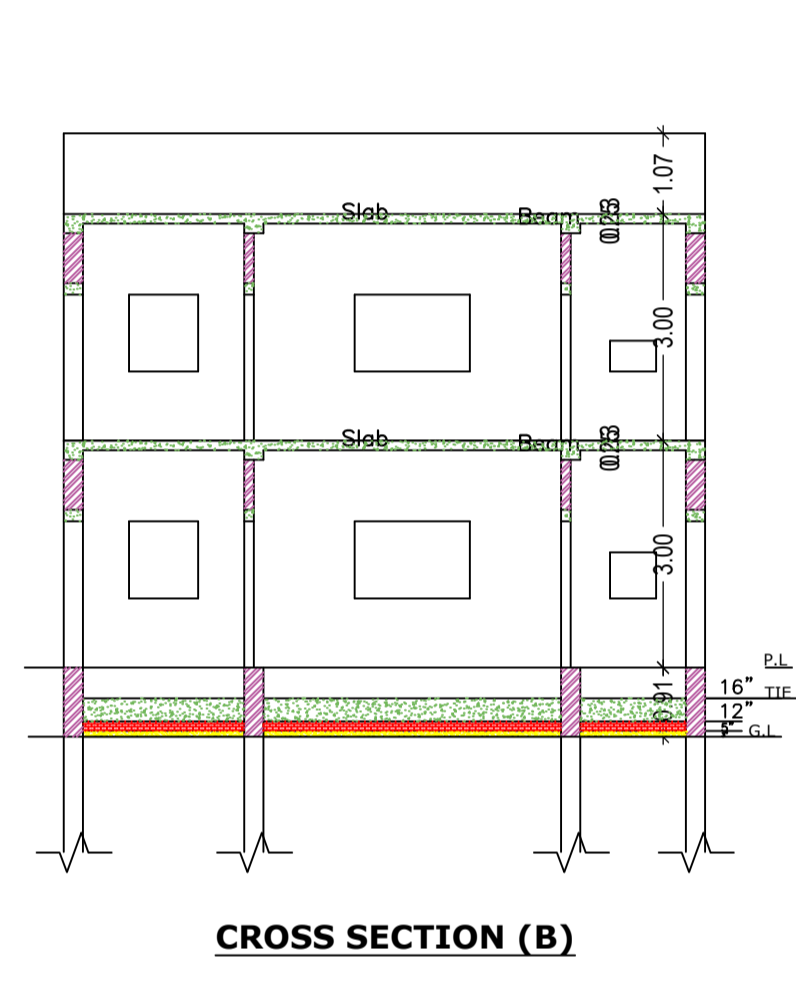
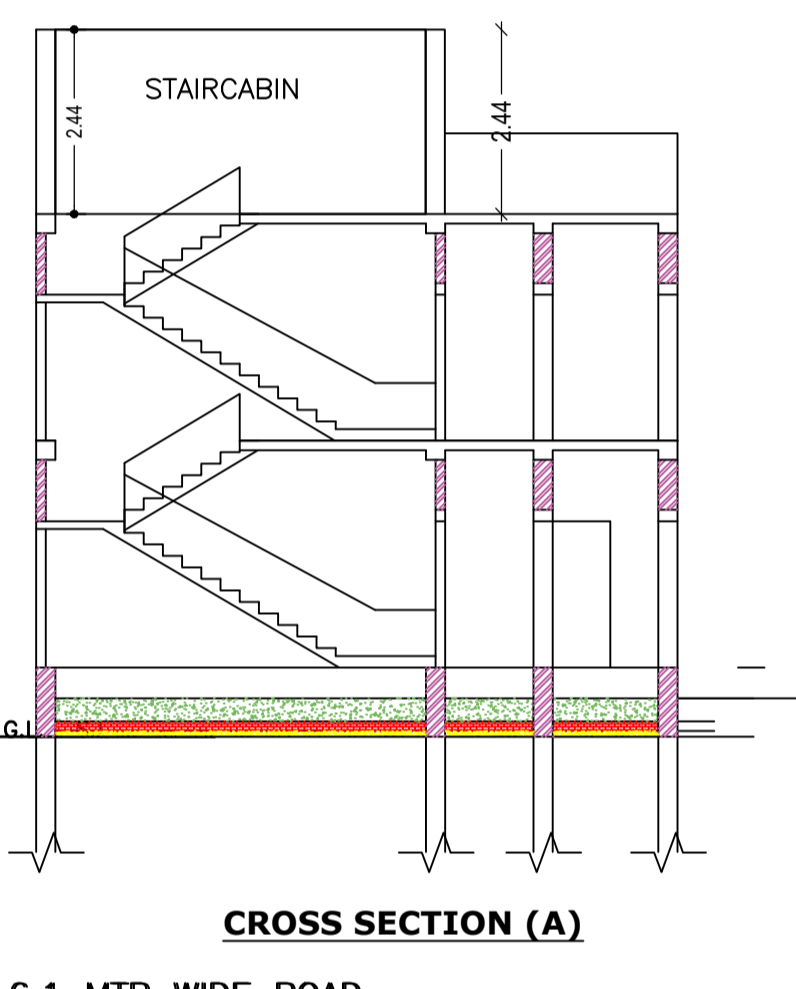
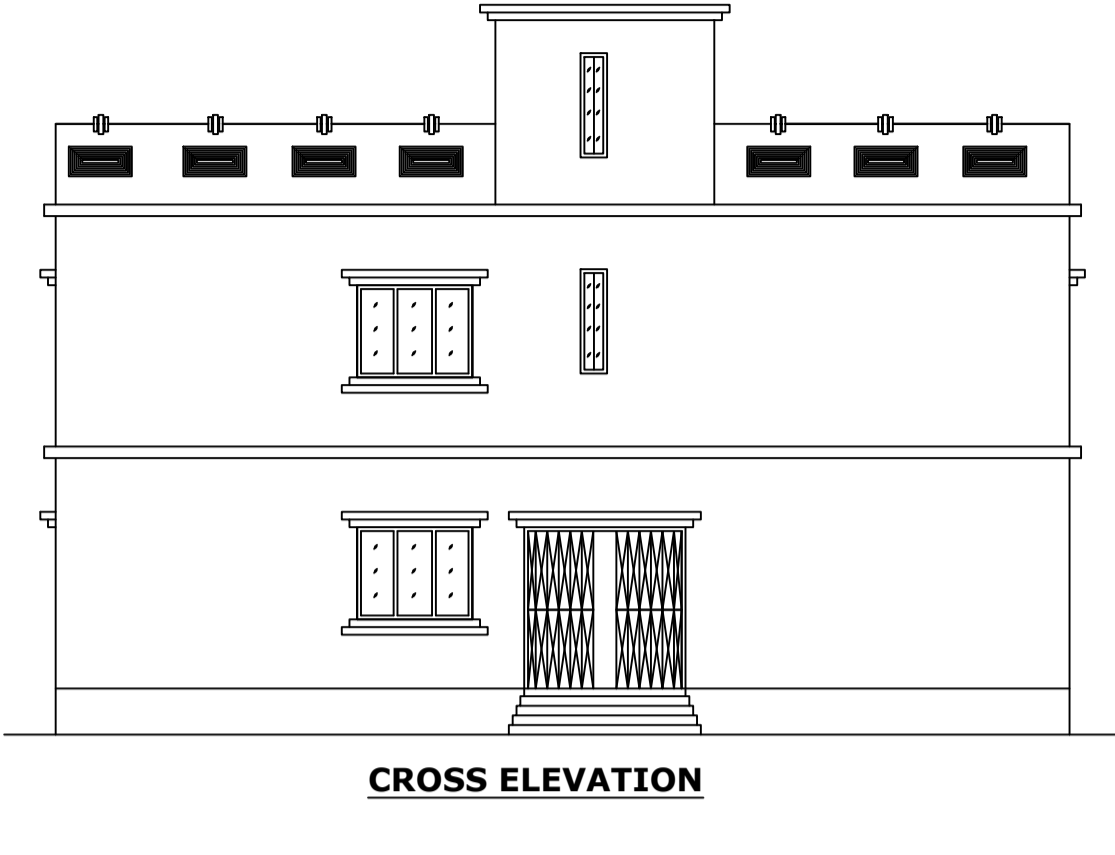
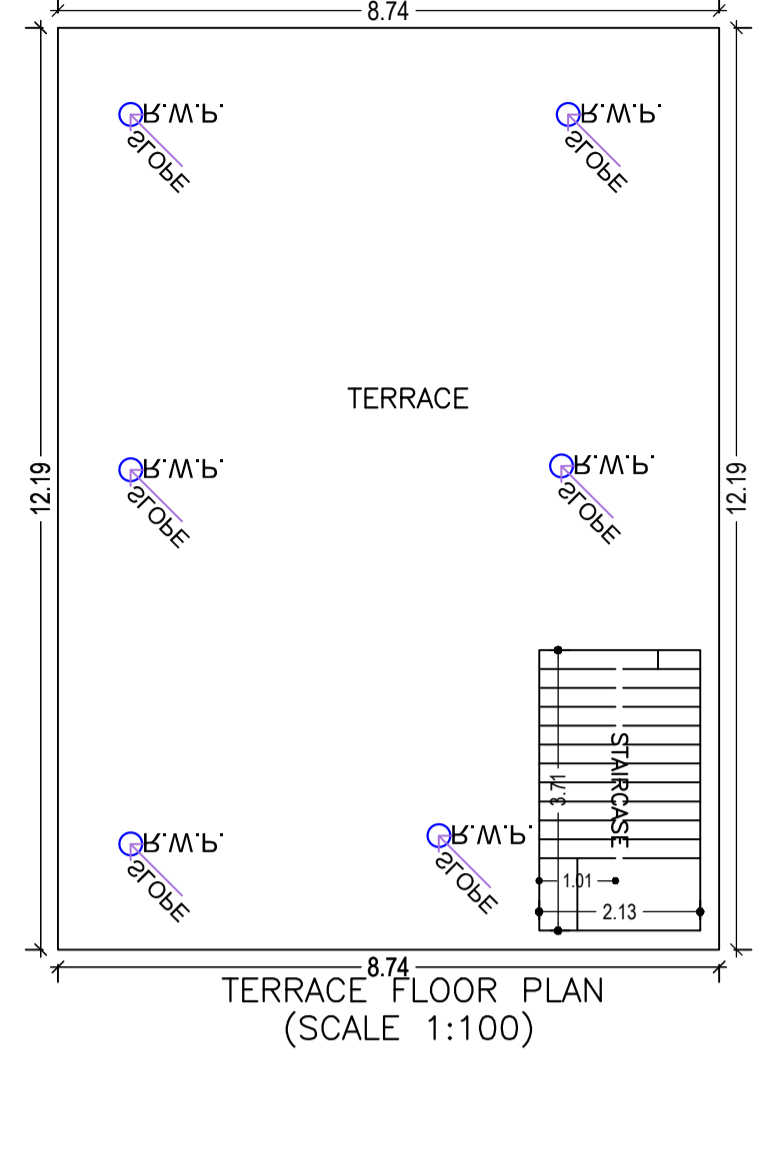
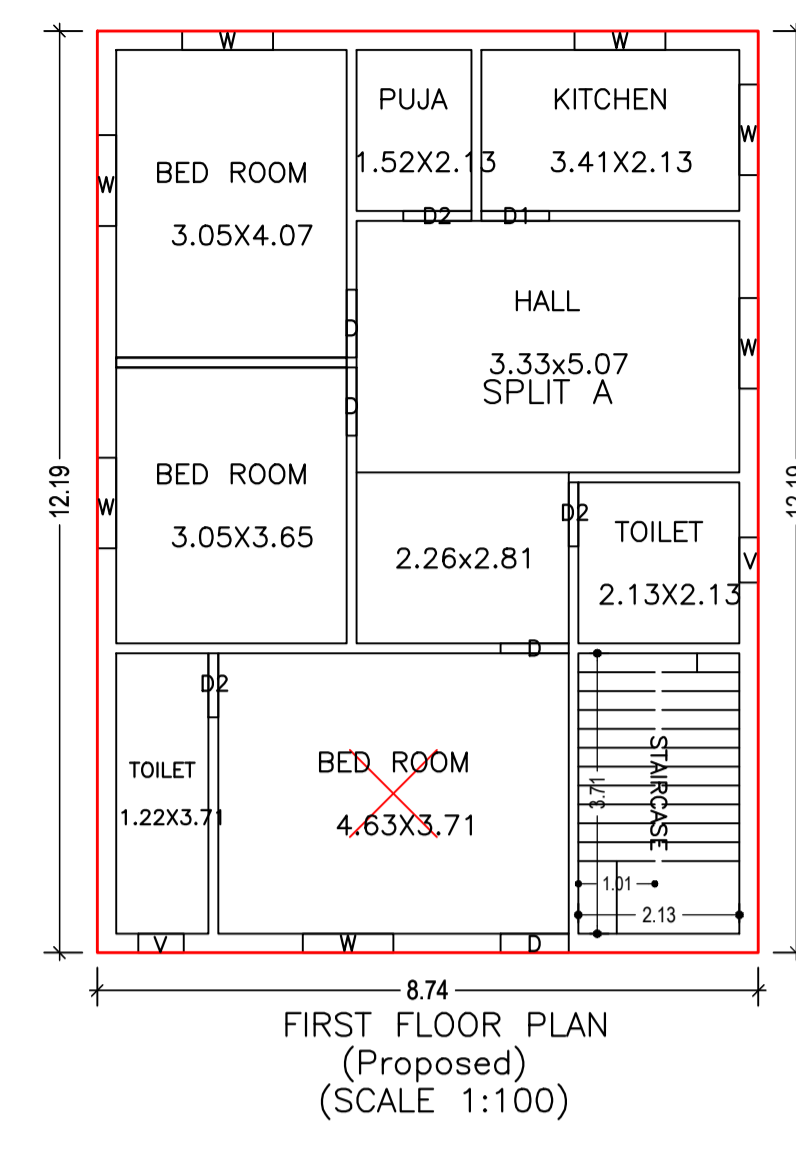
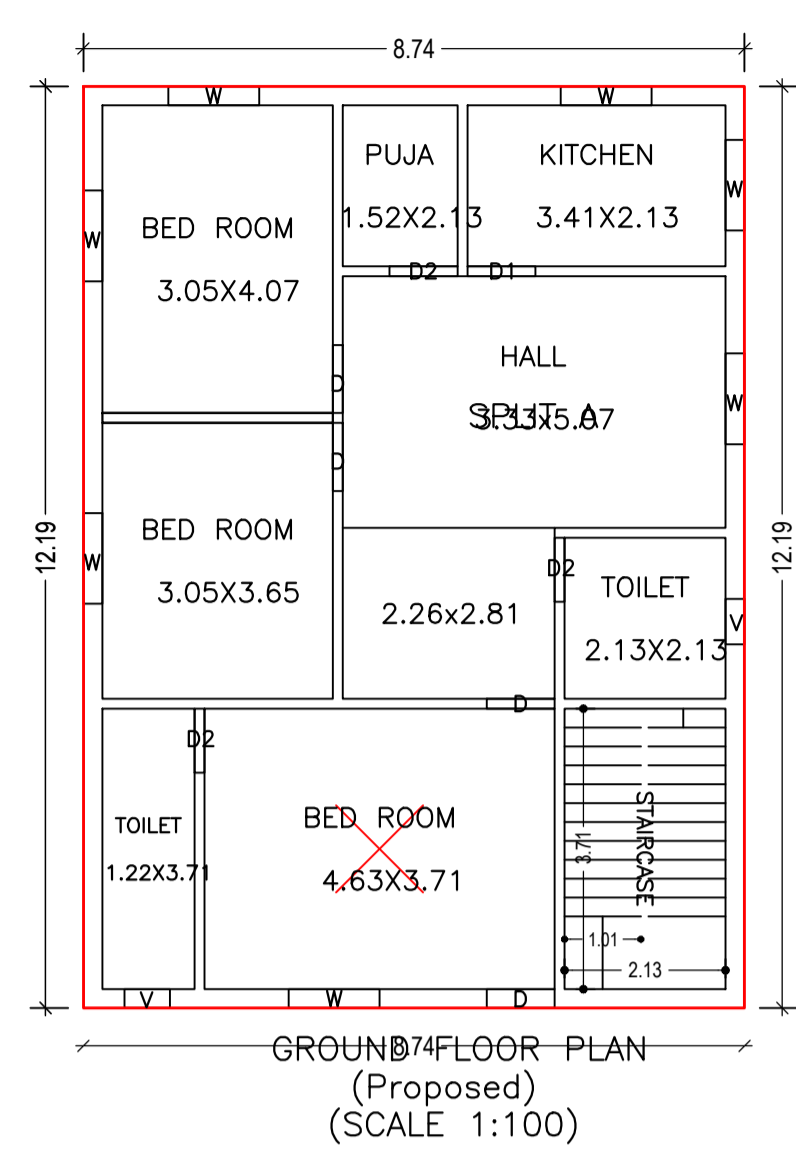
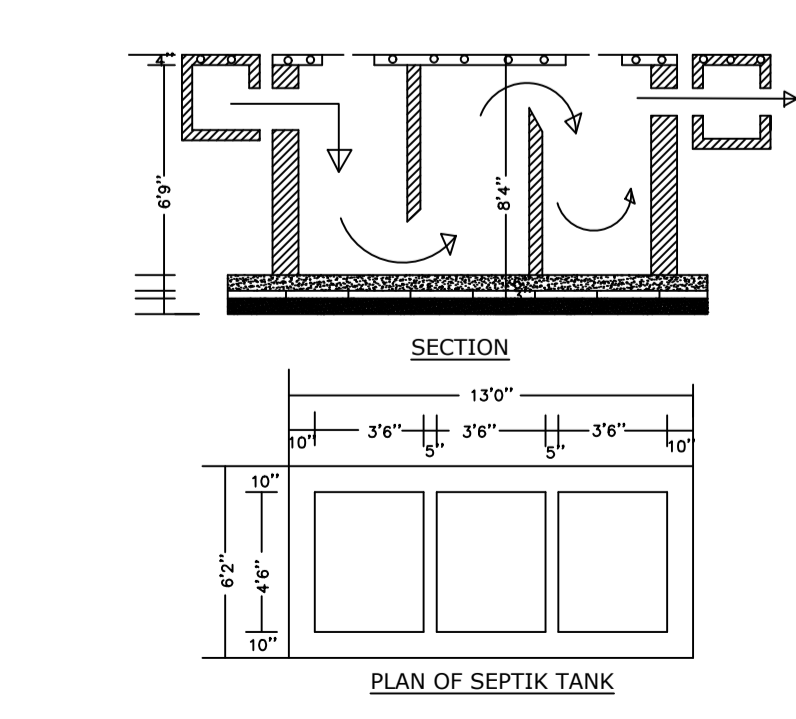
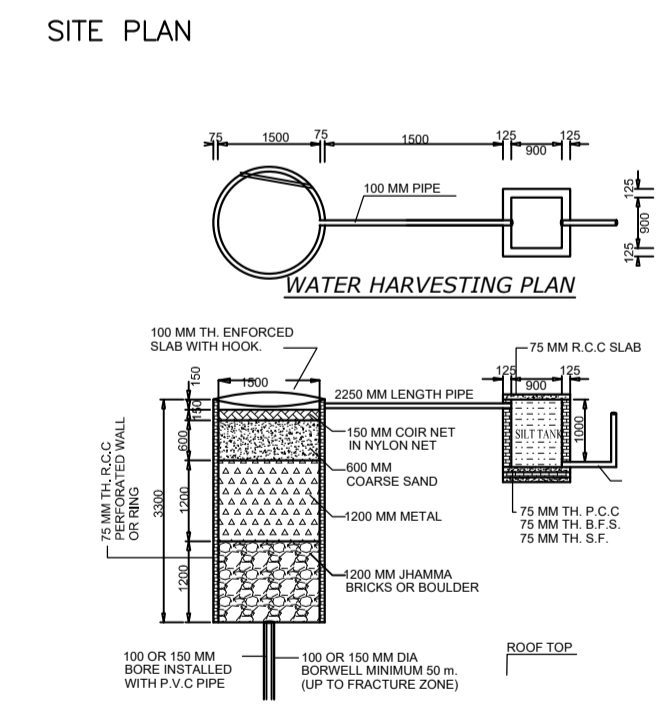
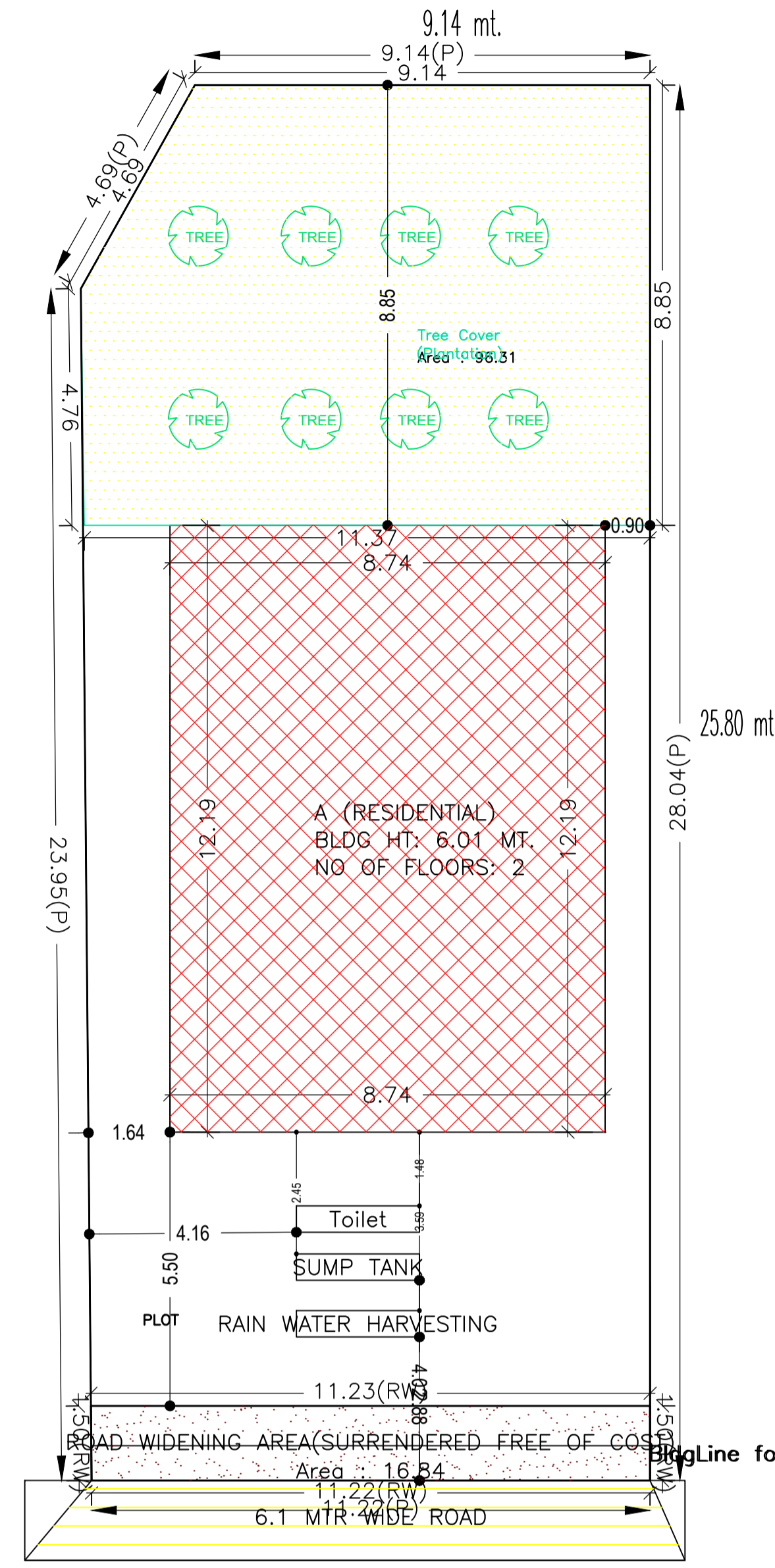

Building :A (RESIDENTIAL)

Floor Name	Total Built Up Area (Sq.mt.)	Proposed FAR Area (Sq.mt.) Resi.	Total FAR Area (Sq.mt.)	Total Consumed Additional FAR Area (Sq.mt.)	Tnmt (No.)
Ground Floor	106.60	106.60	106.60	106.60	01
First Floor	106.60	106.60	106.60	106.60	00
Terrace Floor	0.00	0.00	0.00	0.00	00
Total :	213.20	213.20	213.20	213.20	01
Total Number of Same Buildings	1				
Total :	213.20	213.20	213.20	213.20	01

SCHEDULE OF DOOR:

BUILDING NAME	NAME	LENGTH	HEIGHT	NOS
A (RESIDENTIAL)	D2	0.85	2.10	04
A (RESIDENTIAL)	D	0.90	2.10	08
A (RESIDENTIAL)	D2	0.90	2.10	02
A (RESIDENTIAL)	D1	0.90	2.10	02

SCHEDULE OF WINDOW/VENTILATION:

BUILDING NAME	NAME	LENGTH	HEIGHT	NOS
A (RESIDENTIAL)	V	0.60	0.90	04
A (RESIDENTIAL)	W	1.20	1.20	14

Building USE/SUBUSE Details

Building Name	Building Use	Building SubUse	Building Structure
A (RESIDENTIAL)	Residential	Bungalow/ Dwelling / Non Apartment	Non-Highrise

UnitBUA Table for Building :A (RESIDENTIAL)

FLOOR	Name	UnitBUA Type	UnitBUA Area	Carpet Area	No. of Rooms	No. of Tenement
GROUND FLOOR PLAN	SPLIT A	FLAT	194.35	193.56	8	1
FIRST FLOOR PLAN	SPLIT A	FLAT	0.00	0.00	8	0
Total:	-	-	194.35	193.56	16	1

AREA STATEMENT	VERSION NO. : 1.0.66	SQ.MT.
MEDINAGAR MUNICIPAL CORPORATION	VERSION DATE: 16/10/2020	313.10
PROJECT DETAIL:		
Region: JHARKHAND URBAN LOCAL BODIES	Plot Use: Residential	
District: PALAMU	Plot SubUse: Bungalow/ Dwelling / Non Apartment	
Authority: MEDINAGAR MUNICIPAL CORPORATION	Plot/Nearby/Religious/Structure: NA	
Inward No: MNNP/BP/0040/W03/2023	Plot/SubPlot No: 305/A	
Application Type: General Proposal	North: -	
Project Type: Building Permission	South: -	
Nature of Development: New	East: -	
Location of Development Area: Old Area	West: -	
AREA DETAILS:		
AREA OF PLOT (Minimum)	(A)	313.10
Deduction for NetPlot Area		
Surrender Free of Cost		16.84
Total		16.84
NET AREA OF PLOT(Gross Plot Area - Deduction from Gross Plot area)	(A-Deductions)	296.26
Deduction for Balance Plot Area(from Gross Plot Area)		
Surrender Free of Cost		16.84
Common Plot		96.31
Total		113.15
BALANCE AREA OF PLOT(Net Plot Area - Recreational/Amenity space)	(A-Deductions)	199.95
PLOT AREA FOR COVERAGE(Net Plot Area)	(A-Deductions)	296.26
Plot Area for FAR (Net Plot Area + Road/Widening Area)	(A-Deductions)	313.10
COVERAGE CHECK		
Permissible Coverage area (60.00 %)		177.76
Proposed Coverage Area (35.98 %)		106.60
Total Prop. Coverage Area (35.98 %)		106.60
Balance coverage area (24.02 %)		71.16
FAR CHECK		
Perm. FAR Area (2.500)		782.75
Total Perm. FAR area		782.75
Residential FAR		213.20
Proposed FAR Area		213.20
Total Proposed FAR Area		213.20
Consumed FAR (Factor)		0.68
Balance FAR Area		569.55
BUILT UP AREA CHECK		
Total Proposed BuiltUp Area		213.20
ARCHITECT (Regd)	RANJIT KUMAR	
ENGINEER (Regd)		
SUPERVISOR (Regd)		
OWNER (Regd)	Anant Prasad Shrivastava	
DEVELOPMENT AUTHORITY		LOCAL BODY

Buildingwise Floor FAR Details

Floor Name	Building Name A (RESIDENTIAL)		Total	
	Proposed Built Up Area (Sq.mt.)	Proposed FAR Area (Sq.mt.)	Total Proposed Built Up Area (Sq.mt.)	Total FAR Area (Sq.mt.)
Ground Floor	106.60	106.60	106.60	106.60
First Floor	106.60	106.60	106.60	106.60
Terrace Floor	0.00	0.00	0.00	0.00
Total :	213.20	213.20	213.20	213.20

FAR & Tenement Details (Table 4c-1)

Building	No. of Same Bldg	Total Built Up Area (Sq.mt.)	Proposed FAR Area (Sq.mt.) Resi.	Total FAR Area (Sq.mt.)	Total Consumed Additional FAR Area (Sq.mt.)	Tnmt (No.)
A (RESIDENTIAL)	1	213.20	213.20	213.20	213.20	01
Grand Total :	1	213.20	213.20	213.20	213.20	01

COLOR INDEX

PLOT BOUNDARY	Black
ABUTTING ROAD	Green
PROPOSED CONSTRUCTION	Red
COMMON PLOT	Yellow
ROAD WIDENING AREA	Blue
EXISTING (To be retained)	Light Blue
EXISTING (To be demolished)	Light Yellow

LTP NAME AND SIGNATURE	STRUCTURAL ENG'S NAME AND SIGNATURE	BUILDER NAME AND SIGNATURE	DIGITAL SIGNATURE
RANJIT KUMAR MNNP/ENG/0001/2016			