

Building :A (RESIDENTIAL)

Floor Name	Total Built Up Area (Sq.mt.)	Proposed FAR Area (Sq.mt.) Resi.	Total FAR Area (Sq.mt.)	Total Consumed Additional FAR Area (Sq.mt.)	Tnmt (No.)
Ground Floor	52.28	52.28	52.28	52.28	01
First Floor	52.28	52.28	52.28	52.28	00
Terrace Floor	0.00	0.00	0.00	0.00	00
Total :	104.56	104.56	104.56	104.56	01
Total Number of Same Buildings	1				
Total :	104.56	104.56	104.56	104.56	01

SCHEDULE OF DOOR:

BUILDING NAME	NAME	LENGTH	HEIGHT	NOS
A (RESIDENTIAL)	D	0.90	2.10	01
A (RESIDENTIAL)	D1	0.91	2.10	01
A (RESIDENTIAL)	D	0.91	2.10	01
A (RESIDENTIAL)	D	0.92	2.10	02
A (RESIDENTIAL)	D2	0.93	2.10	01

SCHEDULE OF WINDOW/VENTILATION:

BUILDING NAME	NAME	LENGTH	HEIGHT	NOS
A (RESIDENTIAL)	V	0.60	0.90	01
A (RESIDENTIAL)	W	1.03	1.20	07
A (RESIDENTIAL)	W	1.04	1.20	02

UnitBUA Table for Building :A (RESIDENTIAL)

FLOOR	Name	UnitBUA Type	UnitBUA Area	Carpet Area	No. of Rooms	No. of Tenement
FIRST FLOOR PLAN	SPLIT A	FLAT	0.00	0.00	3	0
GROUND FLOOR PLAN	SPLIT A	FLAT	84.34	83.36	3	1
Total:	-	-	84.34	83.36	6	1

FAR & Tenement Details (Table 4c-1)

Building	No. of Same Bldg	Total Built Up Area (Sq.mt.)	Proposed FAR Area (Sq.mt.) Resi.	Total FAR Area (Sq.mt.)	Total Consumed Additional FAR Area (Sq.mt.)	Tnmt (No.)
A (RESIDENTIAL)	1	104.56	104.56	104.56	104.56	01
Grand Total :	1	104.56	104.56	104.56	104.56	01

Proposal Basic Information

Proposal File No.	MNNP/BP/0136/W03/2023
Owner Name	Kalawati Devi
Khata No	28
Plot No	283
Village Name	Sudna
Use	Residential
SubUse	Bungalow/ Dwelling / Non Apartment

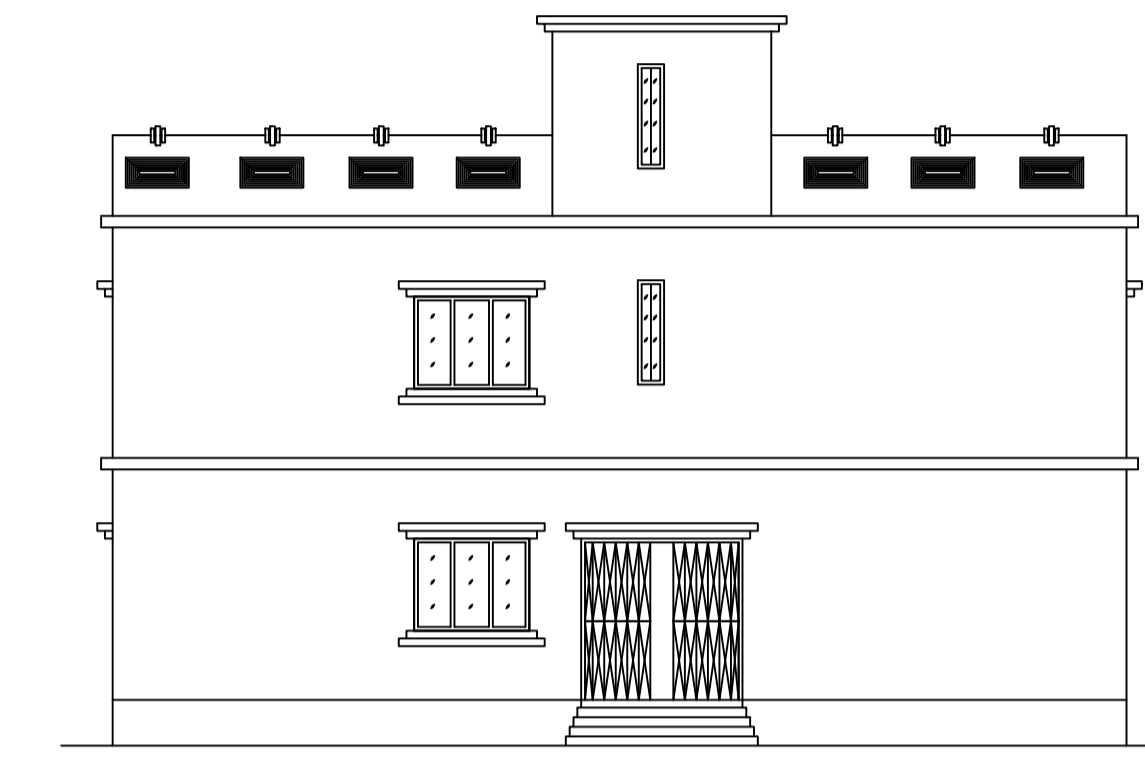

CROSS ELEVATION



FRONT ELEVATION

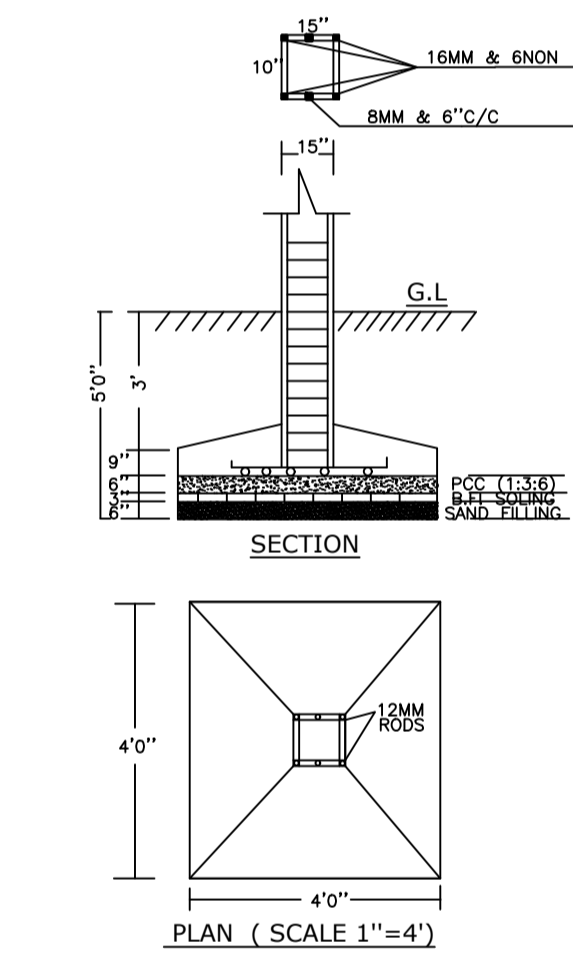

SECTION

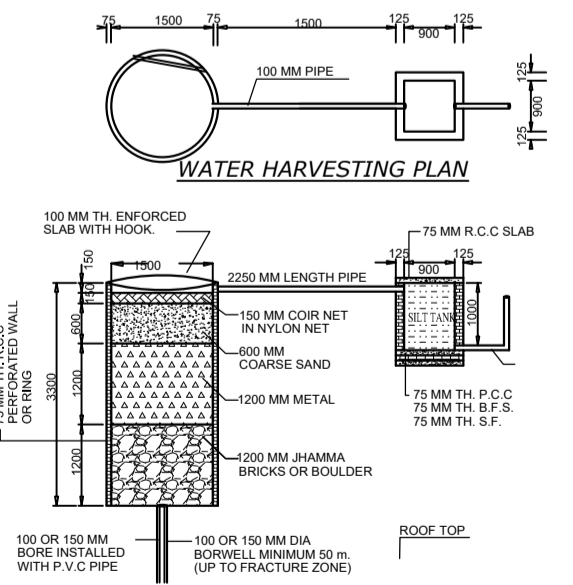

WATER HARVESTING PLAN

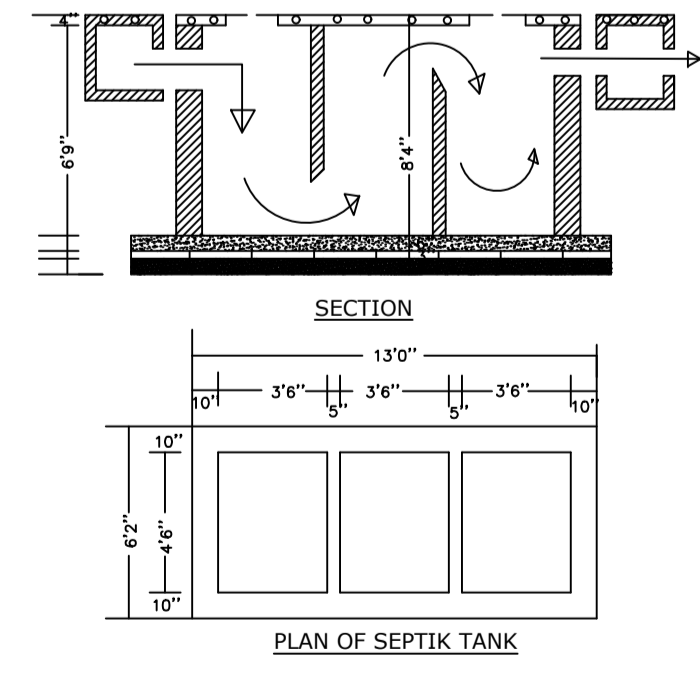

PLAN OF SEPTIC TANK

AREA STATEMENT

AREA DETAILS		SQ.MT.
AREA OF PLOT (Minimum)	(A)	101.00
Deduction for NetPlot Area		
Surrender Free of Cost		11.15
Total		11.15
NET AREA OF PLOT (Gross Plot Area - Deduction from Gross Plot area)	(A-Deductions)	89.85
Deduction for Balance Plot Area (from Gross Plot Area)		
Surrender Free of Cost		11.15
Common Plot		13.71
Total		24.86
BALANCE AREA OF PLOT (Net Plot Area - Recreational/Amenity space)	(A-Deductions)	76.14
PLOT AREA FOR COVERAGE (Net Plot Area)	(A-Deductions)	89.85
Plot Area for FAR (Net Plot Area + Road/Widening Area)	(A-Deductions)	101.00
COVERAGE CHECK		
Permissible Coverage area (70.00 %)		62.89
Proposed Coverage Area (58.19 %)		52.28
Total Prop. Coverage Area (58.19 %)		52.28
Balance coverage area (11.81 %)		10.61
FAR CHECK		
Perm. FAR Area (1.500)		151.50
Total Perm. FAR area		151.50
Residential FAR		104.57
Proposed FAR Area		104.57
Total Proposed FAR Area		104.57
Consumed FAR (Factor)		1.04
Balance FAR Area		46.93
BUILT UP AREA CHECK		
Total Proposed BuiltUp Area		104.56
ARCHITECT (Regd)	RANJIT KUMAR	
ENGINEER (Regd)		
SUPERVISOR (Regd)		
OWNER (Regd)	Kalawati Devi	
DEVELOPMENT AUTHORITY	LOCAL BODY	

COLOR INDEX

PLOT BOUNDARY	[Red Line]
ABUTTING ROAD	[Green Line]
PROPOSED CONSTRUCTION	[Yellow Line]
COMMON PLOT	[Blue Line]
ROAD WIDENING AREA	[Orange Line]
EXISTING (To be retained)	[Grey Line]
EXISTING (To be demolished)	[Black Line]

Buildingwise Floor FAR Details

Floor Name	Building Name A (RESIDENTIAL)		Total	
	Proposed Built Up Area (Sq.mt.)	Proposed FAR Area (Sq.mt.)	Total Proposed Built Up Area (Sq.mt.)	Total FAR Area (Sq.mt.)
Ground Floor	52.28	52.28	52.28	52.28
First Floor	52.28	52.28	52.28	52.28
Terrace Floor	0.00	0.00	0.00	0.00
Total :	104.56	104.56	104.56	104.56

Building USE/SUBUSE Details

Building Name	Building Use	Building SubUse	Building Structure
A (RESIDENTIAL)	Residential	Bungalow/ Dwelling / Non Apartment	Non-Highrise

LTP NAME AND SIGNATURE	STRUCTURAL ENG'S NAME AND SIGNATURE	BUILDER NAME AND SIGNATURE	DIGITAL SIGNATURE
RANJIT KUMAR MNNP/ENG/0001/2016			