

SITE PLAN

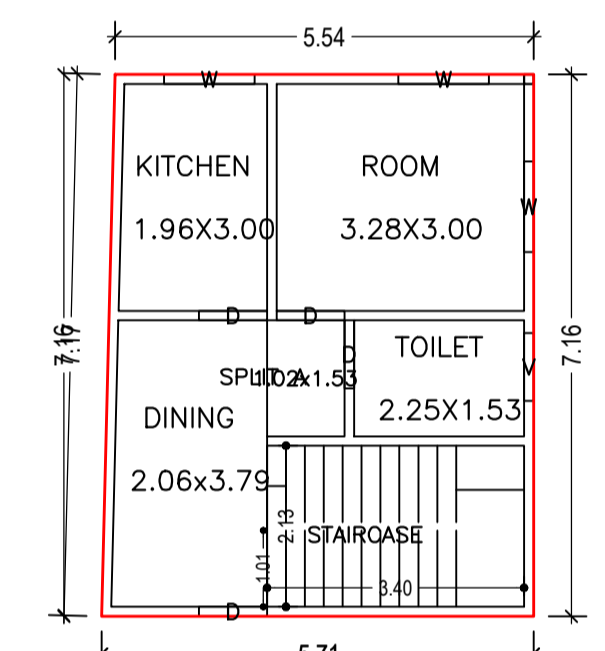

GROUND FLOOR PLAN (Proposed) (SCALE 1:100)

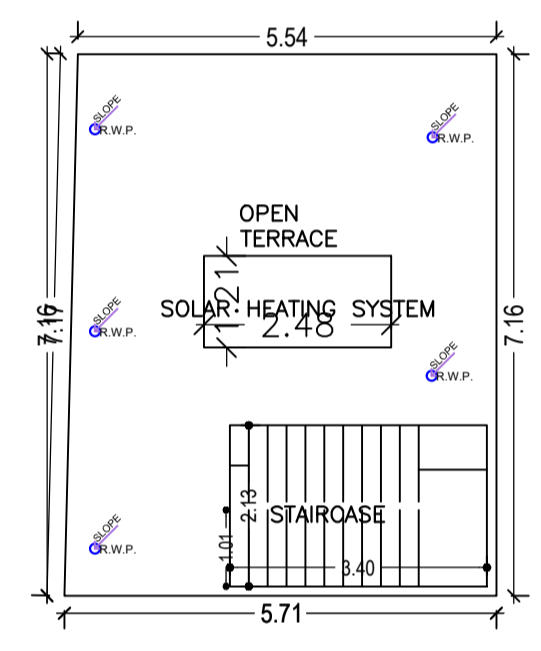

TERRACE FLOOR PLAN (SCALE 1:100)

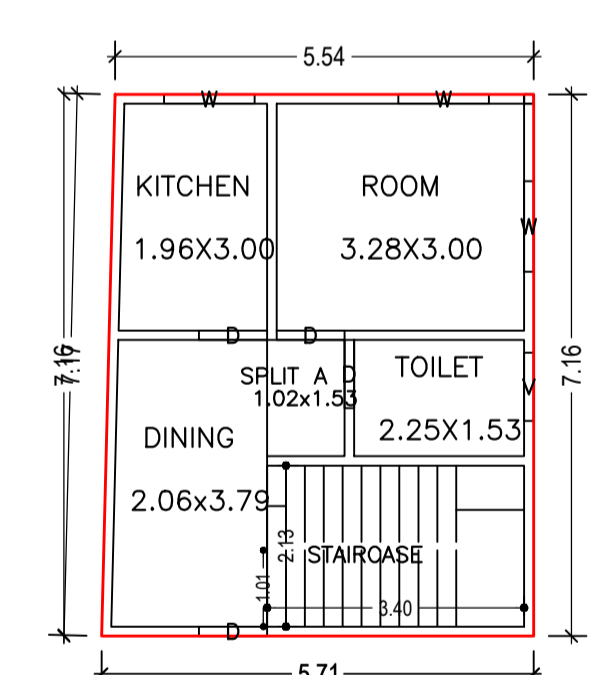

FIRST FLOOR PLAN (Proposed) (SCALE 1:100)

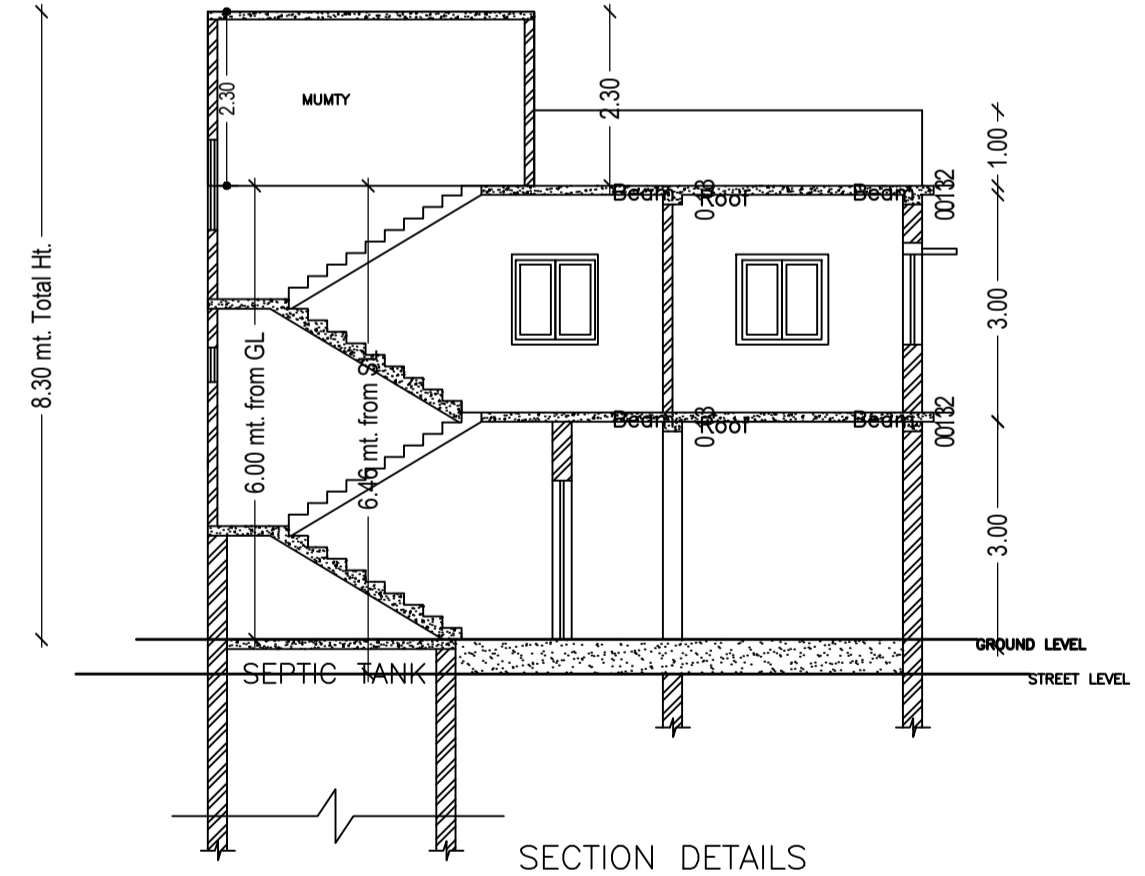

SECTION DETAILS (SCALE 1:100)

FAR & Tenement Details (Table 4c-1)

Building	No. of Same Bldg	Total Built Up Area (Sq.mt.)	Proposed FAR Area (Sq.mt.) Resi.	Total FAR Area (Sq.mt.)	Total Consumed Additional FAR Area (Sq.mt.)	Tnmt (No.)
A (BUILDING)	1	80.60	80.60	80.60	80.60	01
Grand Total :	1	80.60	80.60	80.60	80.60	01

Proposal Basic Information

Proposal File No.	MNNP/BI/0140/W04/2023
Owner Name	Jay Raghunandan Mehta
Khata No	298
Plot No	1315
Village Name	Baralota
Use	Residential
SubUse	Bungalow/ Dwelling / Non Apartment

AREA STATEMENT	VERSION NO. : 1.0.66
MEDININAGAR MUNICIPAL CORPORATION	VERSION DATE: 16/10/2020
PROJECT DETAIL:	
Region: JHARKHAND URBAN LOCAL BODIES	Plot Use: Residential
District: PALAMU	Plot SubUse: Bungalow/ Dwelling / Non Apartment
Authority: MEDININAGAR MUNICIPAL CORPORATION	PlotNearby/ReligiousStructure: NA
Inward No: MNNP/BI/0140/W04/2023	Plot/SubPlot No: 1315
Application Type: General Proposal	North: -
Project Type: Building Permission	South: -
Nature of Development: New	East: -
Location of Development Area: Old Area	West: -
AREA DETAILS:	SQ.MT.
AREA OF PLOT (Minimum)	(A) 79.84
Deduction for NetPlot Area	
Surrender Free of Cost	10.19
Total	10.19
NET AREA OF PLOT(Gross Plot Area - Deduction from Gross Plot area)	(A-Deductions) 69.66
Deduction for Balance Plot Area(from Gross Plot Area)	
Surrender Free of Cost	10.19
Common Plot	8.37
Total	18.56
BALANCE AREA OF PLOT(Net Plot Area - Recreational/Amenity space)	(A-Deductions) 61.29
PLOT AREA FOR COVERAGE(Net Plot Area)	(A-Deductions) 69.66
Plot Area for FAR (Net Plot Area + Road/Widening Area)	(A-Deductions) 79.84
COVERAGE CHECK	
Permissible Coverage area ( 70.00 % )	48.76
Proposed Coverage Area ( 57.86 % )	40.30
Total Prop. Coverage Area ( 57.86 % )	40.30
Balance coverage area ( 12.15 % )	8.46
FAR CHECK	
Perm. FAR Area ( 1.200 )	95.81
Total Perm. FAR area	95.81
Residential FAR	80.61
Proposed FAR Area	80.61
Total Proposed FAR Area	80.61
Consumed FAR (Factor)	80.61
Balance FAR Area	15.20
BUILT UP AREA CHECK	
Total Proposed BuiltUp Area	80.60
ARCHITECT (Regd)	SATYA PRAKASH
ENGINEER (Regd)	
SUPERVISOR (Regd)	
OWNER (Regd)	Jay Raghunandan Mehta
DEVELOPMENT AUTHORITY	LOCAL BODY

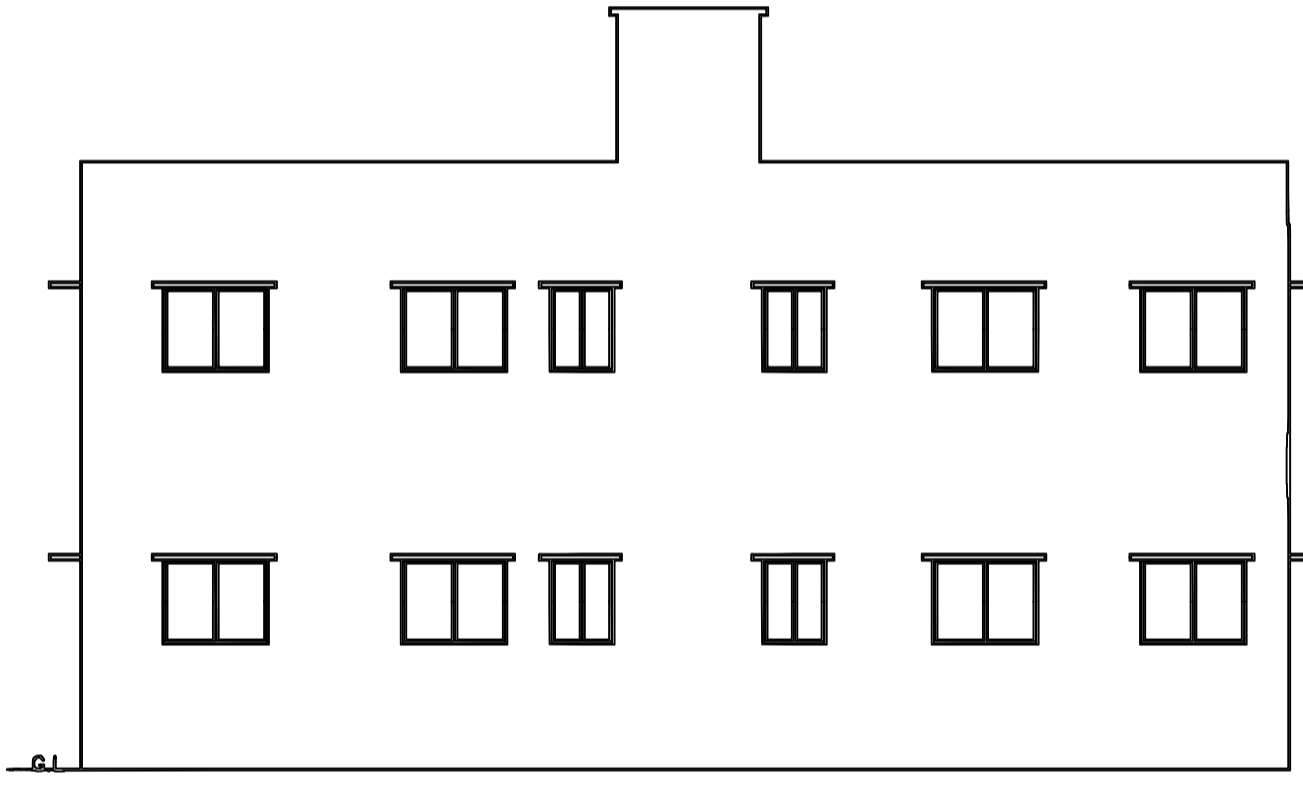
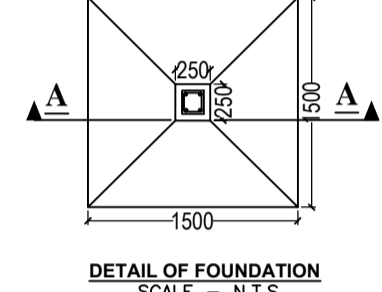
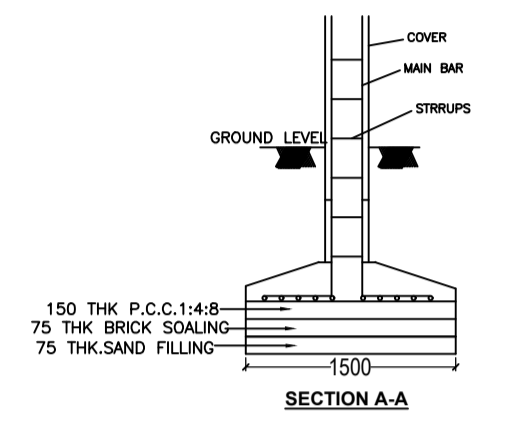
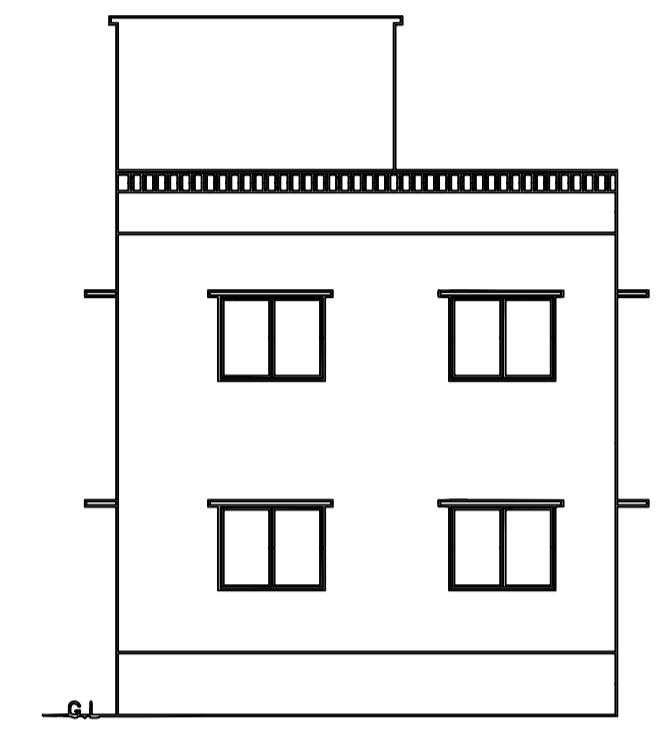

COLOR INDEX	
PLOT BOUNDARY	[Red Line]
ABUTTING ROAD	[Green Line]
PROPOSED CONSTRUCTION	[Yellow Line]
COMMON PLOT	[Blue Line]
ROAD WIDENING AREA	[Orange Line]
EXISTING (To be retained)	[Black Line]
EXISTING (To be demolished)	[White Line]

Buildingwise Floor FAR Details

Floor Name	Building Name A (BUILDING)		Total	
	Proposed Built Up Area (Sq.mt.)	Proposed FAR Area (Sq.mt.)	Total Proposed Built Up Area (Sq.mt.)	Total FAR Area (Sq.mt.)
Ground Floor	40.30	40.30	40.30	40.30
First Floor	40.30	40.30	40.30	40.30
Terrace Floor	0.00	0.00	0.00	0.00
Total :	80.60	80.60	80.60	80.60

Building USE/SUBUSE Details

Building Name	Building Use	Building SubUse	Building Structure
A (BUILDING)	Residential	Bungalow/ Dwelling / Non Apartment	Non-Highrise

Building :A (BUILDING)

Floor Name	Total Built Up Area (Sq.mt.)	Proposed FAR Area (Sq.mt.) Resi.	Total FAR Area (Sq.mt.)	Total Consumed Additional FAR Area (Sq.mt.)	Tnmt (No.)
Ground Floor	40.30	40.30	40.30	40.30	01
First Floor	40.30	40.30	40.30	40.30	00
Terrace Floor	0.00	0.00	0.00	0.00	00
Total :	80.60	80.60	80.60	80.60	01
Total Number of Same Buildings	1				
Total :	80.60	80.60	80.60	80.60	01

SCHEDULE OF DOOR:

BUILDING NAME	NAME	LENGTH	HEIGHT	NOS
A (BUILDING)	D	0.90	2.10	08

SCHEDULE OF WINDOW/VENTILATION:

BUILDING NAME	NAME	LENGTH	HEIGHT	NOS
A (BUILDING)	V	0.90	0.60	02
A (BUILDING)	W	1.20	1.20	06

UnitBUA Table for Building :A (BUILDING)

FLOOR	Name	UnitBUA Type	UnitBUA Area	Carpet Area	No. of Rooms	No. of Tenement
GROUND FLOOR PLAN	SPLIT A	FLAT	64.71	64.68	4	1
FIRST FLOOR PLAN	SPLIT A	FLAT	0.00	0.00	4	0
Total:	-	-	64.71	64.68	8	1

