

SITE PLAN SCALE 1:100

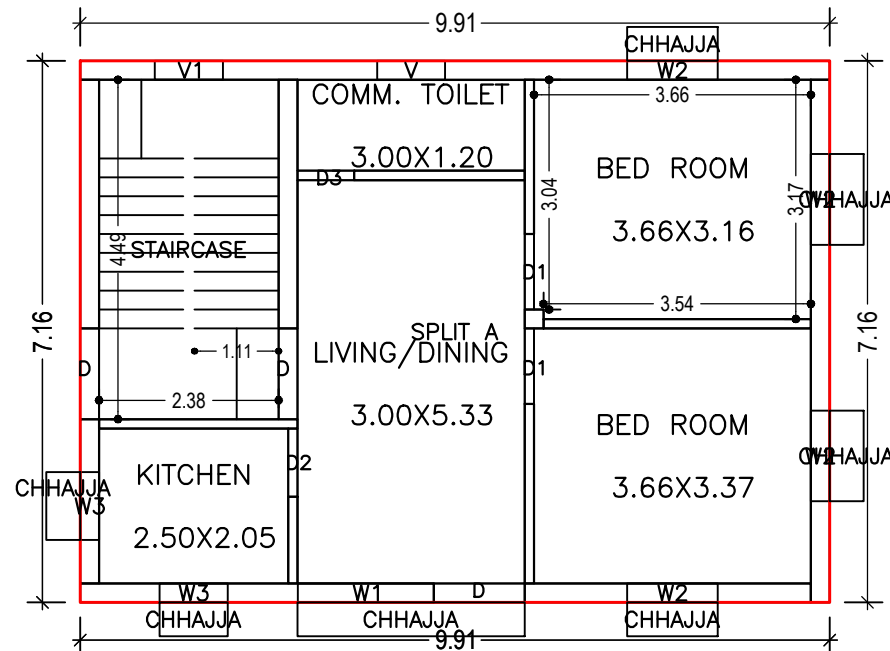

GROUND FLOOR PLAN (Proposed) SCALE 1:100

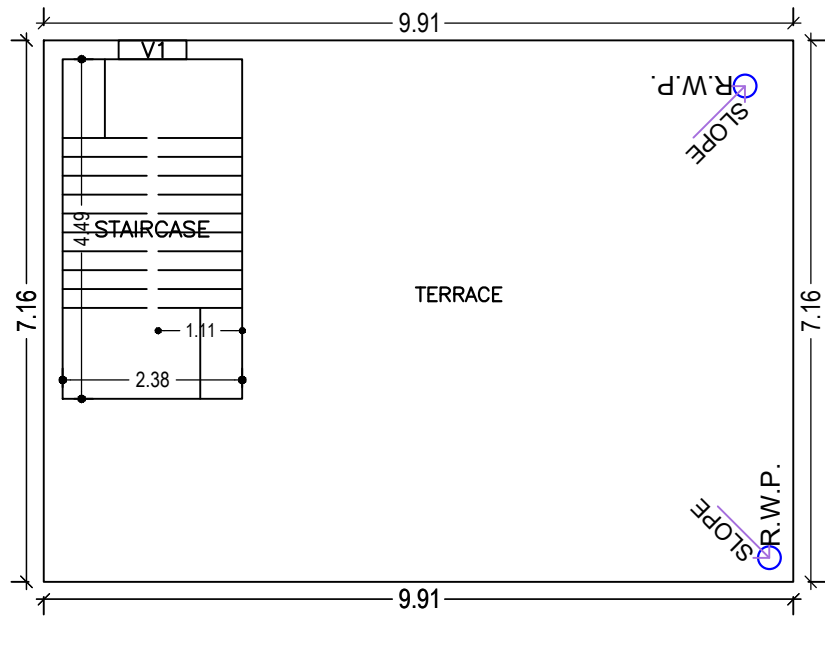

TERRACE FLOOR PLAN (SCALE 1:100)

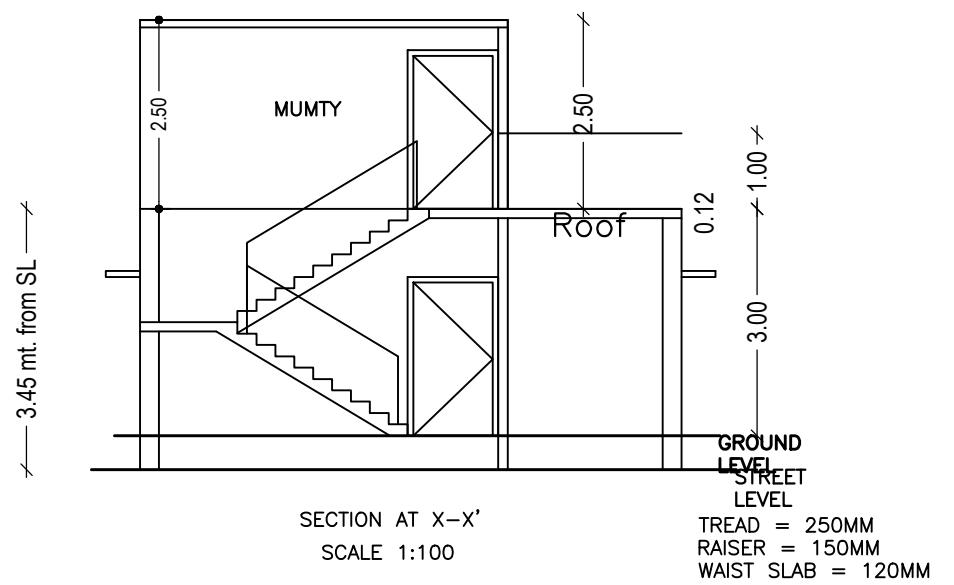

SECTION AT X-X' SCALE 1:100

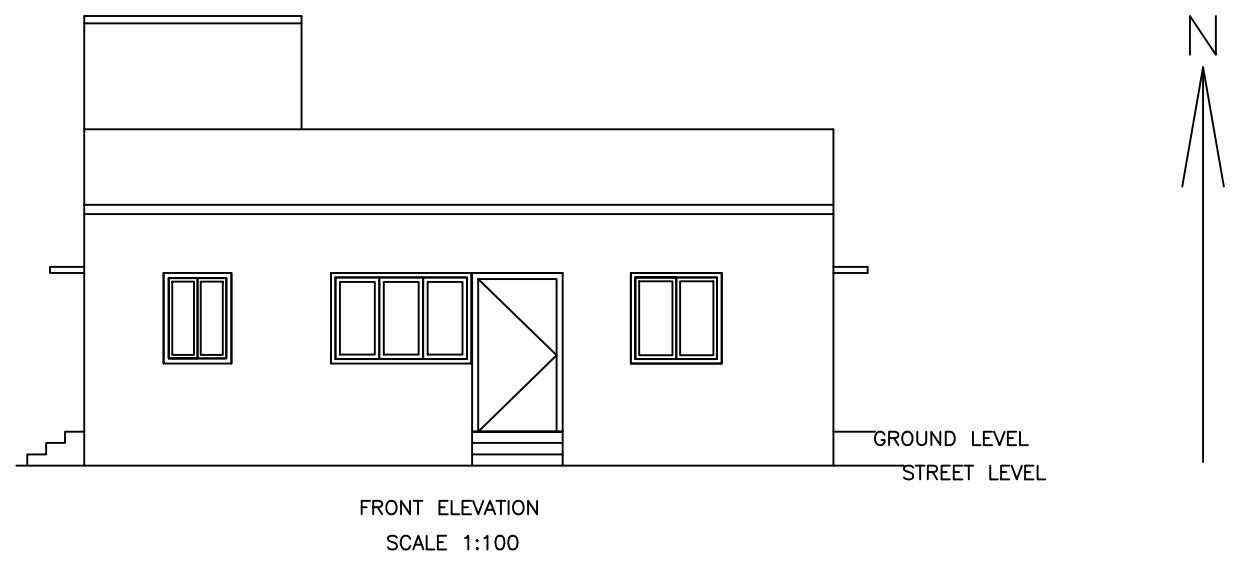

FRONT ELEVATION SCALE 1:100

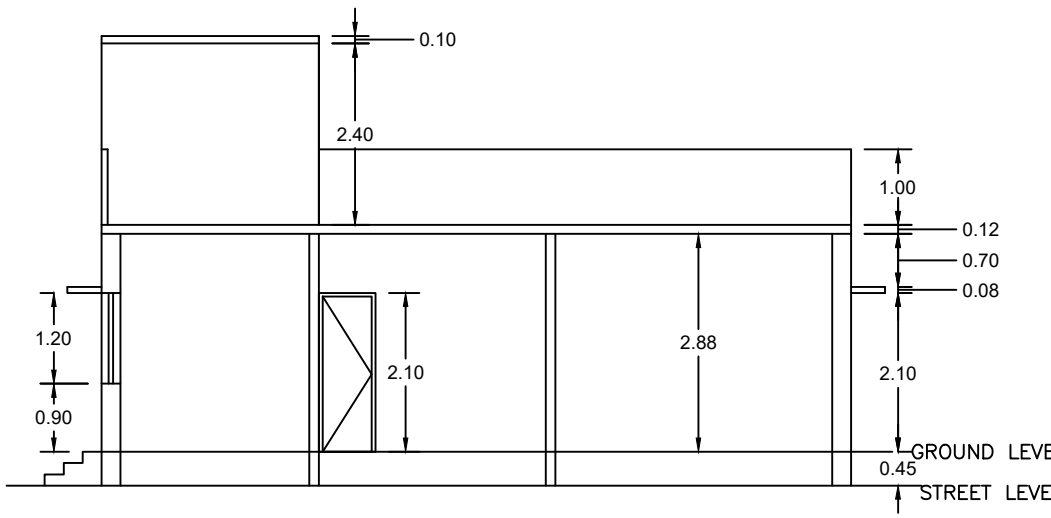

SECTION AT Y-Y' SCALE 1:100

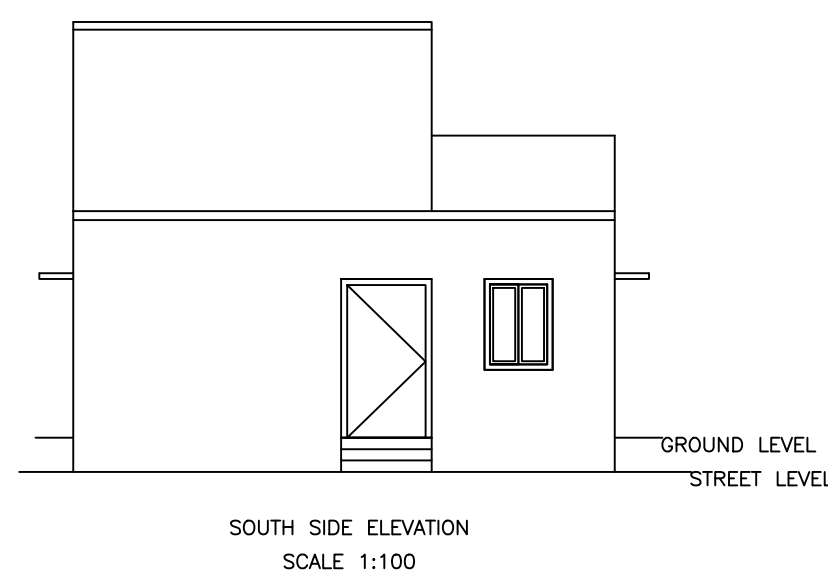

SOUTH SIDE ELEVATION SCALE 1:100

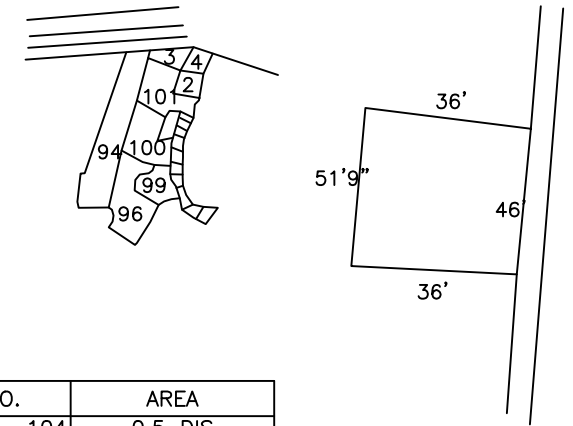

KEY PLAN

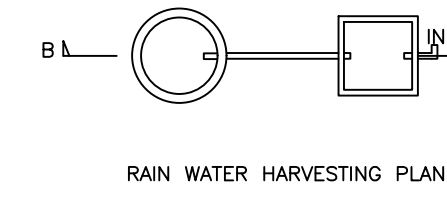

RAIN WATER HARVESTING PLAN

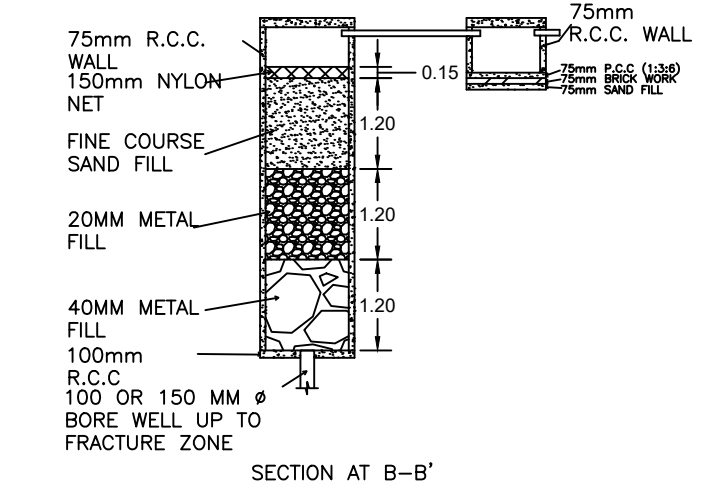

RAIN WATER HARVESTING DETAILS SCALE 1:100

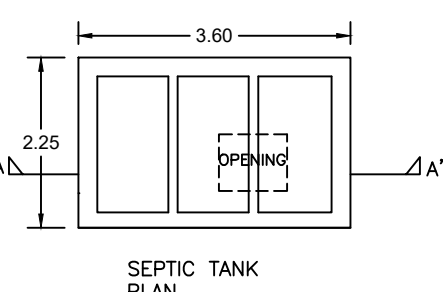

SEPTIC TANK PLAN

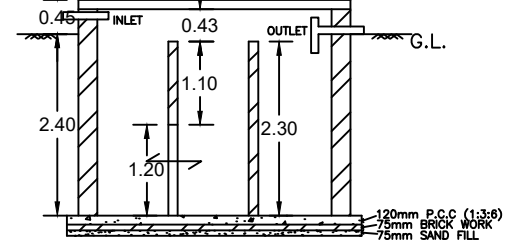

SEPTIC TANK DETAILS SCALE 1:100

FAR & Tenement Details (Table 4c-1)

Building	No. of Same Bldg	Total Built Up Area (Sq.mt.)	Proposed FAR Area (Sq.mt.) Resi.	Total FAR Area (Sq.mt.)	Total Consumed Additional FAR Area (Sq.mt.)	Tnmt (No.)
A (PLOT NO 100)	1	71.01	71.01	71.01	71.01	01
Grand Total :	1	71.01	71.01	71.01	71.01	01

Proposal Basic Information

Proposal File No.	MNNP/BI/0161/W07/2023
Owner Name	RAVINDRA NATH PATHAK
Khata No	178, 178, 177
Plot No	100, 101, 104
Village Name	Redma
Use	Residential
SubUse	Bungalow/ Dwelling / Non Apartment

AREA STATEMENT	VERSION NO. : 1.0.66
MEDININAGAR MUNICIPAL CORPORATION	VERSION DATE: 16/10/2020
PROJECT DETAIL:	
Region: JHARKHAND URBAN LOCAL BODIES	Plot Use: Residential
District: PALAMU	Plot SubUse: Bungalow/ Dwelling / Non Apartment
Authority: MEDININAGAR MUNICIPAL CORPORATION	PlotNearby/ReligiousStructure: NA
Inward No: MNNP/BI/0161/W07/2023	Plot/SubPlot No: 100, 101, 104
Application Type: General Proposal	North: -
Project Type: Building Permission	South: -
Nature of Development: New	East: -
Location of Development Area: Old Area	West: -
AREA DETAILS:	SQ.MT.
AREA OF PLOT (Minimum)	(A) 163.29
Deduction for NetPlot Area	
Road Widening Area	13.80
Total	13.80
NET AREA OF PLOT(Gross Plot Area - Deduction from Gross Plot area)	(A-Deductions) 149.49
Deduction for Balance Plot Area(from Gross Plot Area)	
Road Widening Area	13.80
Common Plot	21.08
Total	34.87
BALANCE AREA OF PLOT(Net Plot Area - Recreational/Amenity space)	(A-Deductions) 128.41
PLOT AREA FOR COVERAGE(Net Plot Area)	(A-Deductions) 149.49
Plot Area for FAR (Net Plot Area + RoadWidening Area)	(A-Deductions) 149.49
COVERAGE CHECK	
Permissible Coverage area (70.00 %)	104.64
Proposed Coverage Area (47.50 %)	71.01
Total Prop. Coverage Area (47.5 %)	71.01
Balance coverage area (22.50 %)	33.63
FAR CHECK	
Perm. FAR Area (1.200)	179.39
Total Perm. FAR area	179.39
Residential FAR	71.01
Proposed FAR Area	71.01
Total Proposed FAR Area	71.01
Consumed FAR (Factor)	0.48
Balance FAR Area	108.38
BUILT UP AREA CHECK	
Total Proposed BuiltUp Area	71.01
ARCHITECT (Regd)	MD MOHSIN AKHATAR
ENGINEER (Regd)	
SUPERVISOR (Regd)	
OWNER (Regd)	RAVINDRA NATH PATHAK
DEVELOPMENT AUTHORITY	LOCAL BODY

COLOR INDEX	
PLOT BOUNDARY	Black
ABUTTING ROAD	Green
PROPOSED CONSTRUCTION	Red
COMMON PLOT	Yellow
ROAD WIDENING AREA	Blue
EXISTING (To be retained)	Light Blue
EXISTING (To be demolished)	Orange

Buildingwise Floor FAR Details

Floor Name	Building Name A (PLOT NO 100)		Total	
	Proposed Built Up Area (Sq.mt.)	Proposed FAR Area (Sq.mt.)	Total Proposed Built Up Area (Sq.mt.)	Total FAR Area (Sq.mt.)
Ground Floor	71.01	71.01	71.01	71.01
Terrace Floor	0.00	0.00	0.00	0.00
Total :	71.01	71.01	71.01	71.01

Building USE/SUBUSE Details

Building Name	Building Use	Building SubUse	Building Structure
A (PLOT NO 100)	Residential	Bungalow/ Dwelling / Non Apartment	Non-Highrise

Building :A (PLOT NO 100)

Floor Name	Total Built Up Area (Sq.mt.)	Proposed FAR Area (Sq.mt.) Resi.	Total FAR Area (Sq.mt.)	Total Consumed Additional FAR Area (Sq.mt.)	Tnmt (No.)
Ground Floor	71.01	71.01	71.01	71.01	01
Terrace Floor	0.00	0.00	0.00	0.00	00
Total :	71.01	71.01	71.01	71.01	01
Total Number of Same Buildings	1				
Total :	71.01	71.01	71.01	71.01	01

SCHEDULE OF DOOR:

BUILDING NAME	NAME	LENGTH	HEIGHT	NOS
A (PLOT NO 100)	D3	0.75	2.10	01
A (PLOT NO 100)	D2	0.90	2.10	01
A (PLOT NO 100)	D1	1.00	2.10	02
A (PLOT NO 100)	D	1.20	2.10	02

SCHEDULE OF WINDOW/VENTILATION:

BUILDING NAME	NAME	LENGTH	HEIGHT	NOS
A (PLOT NO 100)	V	0.90	0.60	01
A (PLOT NO 100)	W3	0.90	1.20	02
A (PLOT NO 100)	V1	0.90	3.00	02
A (PLOT NO 100)	W2	1.20	1.20	04
A (PLOT NO 100)	W1	1.80	1.20	01

UnitBUA Table for Building :A (PLOT NO 100)

FLOOR	Name	UnitBUA Type	UnitBUA Area	Carpet Area	No. of Rooms	No. of Tenement
GROUND FLOOR PLAN	SPLIT A	FLAT	71.01	60.69	5	1
Total:	-	-	71.01	60.69	5	1

LTP NAME AND SIGNATURE	STRUCTURAL ENG'S NAME AND SIGNATURE	BUILDER NAME AND SIGNATURE	DIGITAL SIGNATURE
MD MOHSIN AKHATAR MNNP/ENG/0001/2022			