

site plan

FAR & Tenement Details (Table 4c-1)

Building	No. of Same Bldg	Total Built Up Area (Sq.mt.)	Proposed FAR Area (Sq.mt.) Resi.	Total FAR Area (Sq.mt.)	Total Consumed Additional FAR Area (Sq.mt.)	Tnmt (No.)
A (BUILDING)	1	242.06	242.06	242.06	242.06	01
Grand Total :	1	242.06	242.06	242.06	242.06	01

Proposal Basic Information

Proposal File No.	MNNP/BP/0120/W04/2023
Owner Name	RAMCHEDI SINGH AND VISHWASH SINGH
Khata No	320
Plot No	1679
Village Name	Baralota
Use	Residential
SubUse	Bungalow/ Dwelling / Non Apartment

AREA STATEMENT	VERSION NO. : 1.0.66
MEDININAGAR MUNICIPAL CORPORATION	VERSION DATE: 16/10/2020
PROJECT DETAIL:	
Region: JHARKHAND URBAN LOCAL BODIES	Plot Use: Residential
District: PALAMU	Plot SubUse: Bungalow/ Dwelling / Non Apartment
Authority: MEDININAGAR MUNICIPAL CORPORATION	PlotNearbyReligiousStructure: NA
Inward No: MNNP/BP/0120/W04/2023	Plot/SubPlot No: 1679
Application Type: General Proposal	North: -
Project Type: Building Permission	South: -
Nature of Development: New	East: -
Location of Development Area: New Area	West: -
AREA DETAILS:	
AREA OF PLOT (Minimum)	(A) 207.05
Deduction for NetPlot Area	
Surrender Free of Cost	17.66
Total	17.66
NET AREA OF PLOT(Gross Plot Area - Deduction from Gross Plot area)	(A-Deductions) 189.39
Deduction for Balance Plot Area(from Gross Plot Area)	
Surrender Free of Cost	17.66
Common Plot	15.17
Total	32.83
BALANCE AREA OF PLOT(Net Plot Area - Recreational/Amenity space)	(A-Deductions) 174.22
PLOT AREA FOR COVERAGE(Net Plot Area)	(A-Deductions) 189.39
Plot Area for FAR (Net Plot Area + RoadWidening Area)	(A-Deductions) 207.05
COVERAGE CHECK	
Permissible Coverage area ( 70.00 % )	132.57
Proposed Coverage Area ( 63.91 % )	121.03
Total Prop. Coverage Area ( 63.91 % )	121.03
Balance coverage area ( 6.09 % )	11.54
FAR CHECK	
Perm. FAR Area ( 1.500 )	310.58
Total Perm. FAR area	310.58
Residential FAR	242.06
Proposed FAR Area	242.06
Total Proposed FAR Area	242.06
Consumed FAR (Factor)	1.17
Balance FAR Area	68.53
BUILT UP AREA CHECK	
Total Proposed BuiltUp Area	242.06
ARCHITECT (Regd)	MD ZAQUEALLAH
ENGINEER (Regd)	
SUPERVISOR (Regd)	
OWNER (Regd)	RAMCHEDI SINGH AND VISHWASH SINGH
DEVELOPMENT AUTHORITY	
LOCAL BODY	

COLOR INDEX	
PLOT BOUNDARY	Black
ABUTTING ROAD	Green
PROPOSED CONSTRUCTION	Red
COMMON PLOT	Yellow
ROAD WIDENING AREA	Blue
EXISTING (To be retained)	Light Blue
EXISTING (To be demolished)	Light Yellow

Buildingwise Floor FAR Details

Floor Name	Building Name		Total	
	Proposed Built Up Area (Sq.mt.)	Proposed FAR Area (Sq.mt.)	Total Proposed Built Up Area (Sq.mt.)	Total FAR Area (Sq.mt.)
Ground Floor	121.03	121.03	121.03	121.03
First Floor	121.03	121.03	121.03	121.03
Terrace Floor	0.00	0.00	0.00	0.00
Total :	242.06	242.06	242.06	242.06

Building USE/SUBUSE Details

Building Name	Building Use	Building SubUse	Building Structure
A (BUILDING)	Residential	Residential Bldg/Apartment	Non-Highrise

LTP NAME AND SIGNATURE	STRUCTURAL ENG'S NAME AND SIGNATURE	BUILDER NAME AND SIGNATURE	DIGITAL SIGNATURE
MD ZAQUEALLAH MNNP/ENG/0002/2021			

Proposal Basic Information	
Proposal File No.	MNNP/BP/0120/W04/2023
Owner Name	RAMCHEDI SINGH AND VISHWASH SINGH
Khata No	320
Plot No	1679
Village Name	Baralota
Use	Residential
SubUse	Bungalow/ Dwelling / Non Apartment

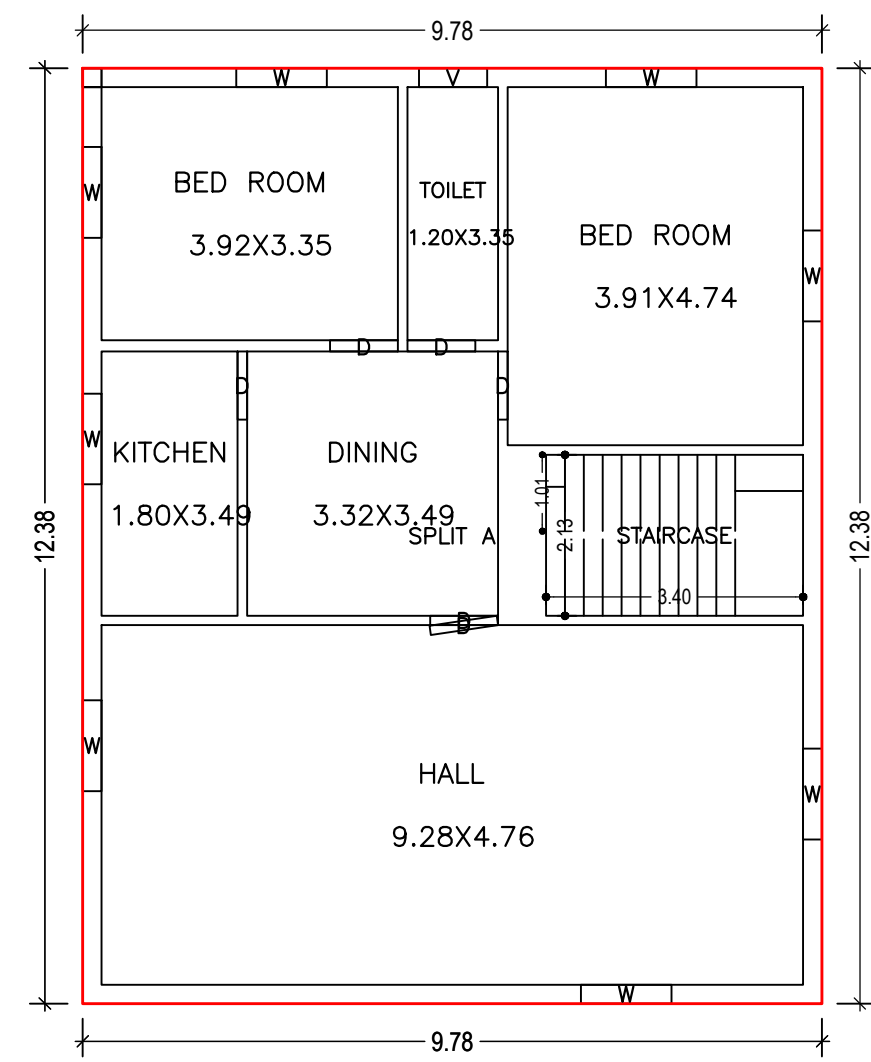

GROUND FLOOR PLAN (Proposed) (SCALE 1:100)

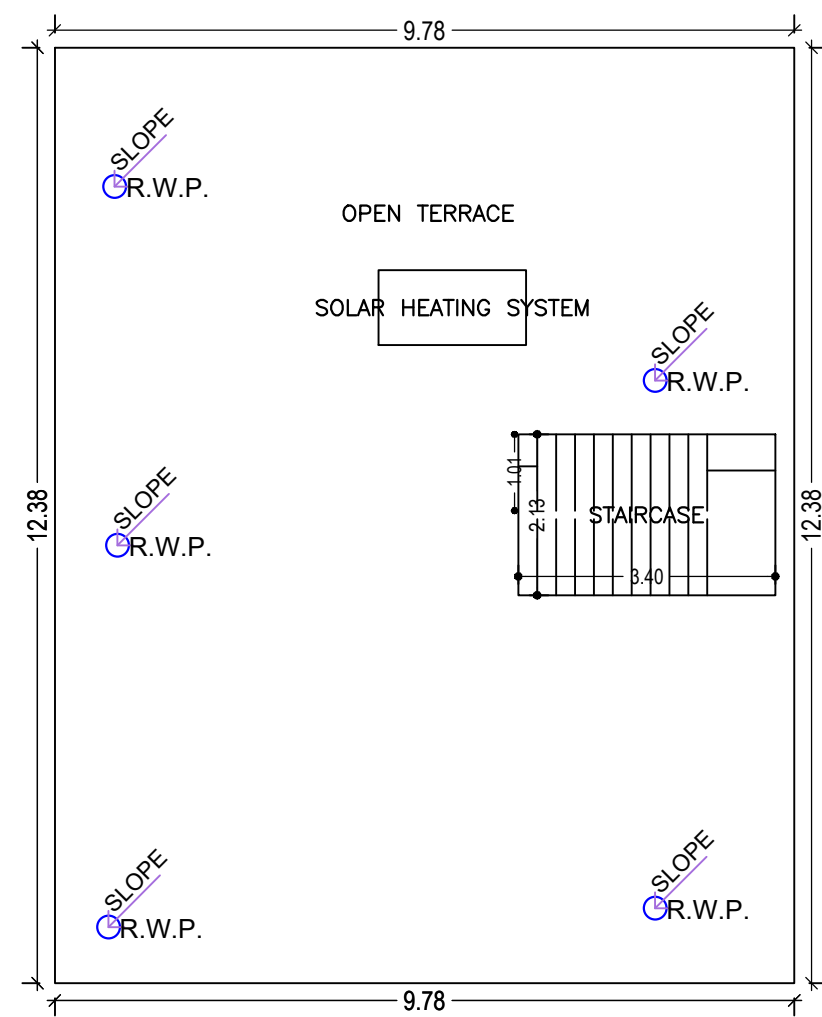

TERRACE FLOOR PLAN (SCALE 1:100)

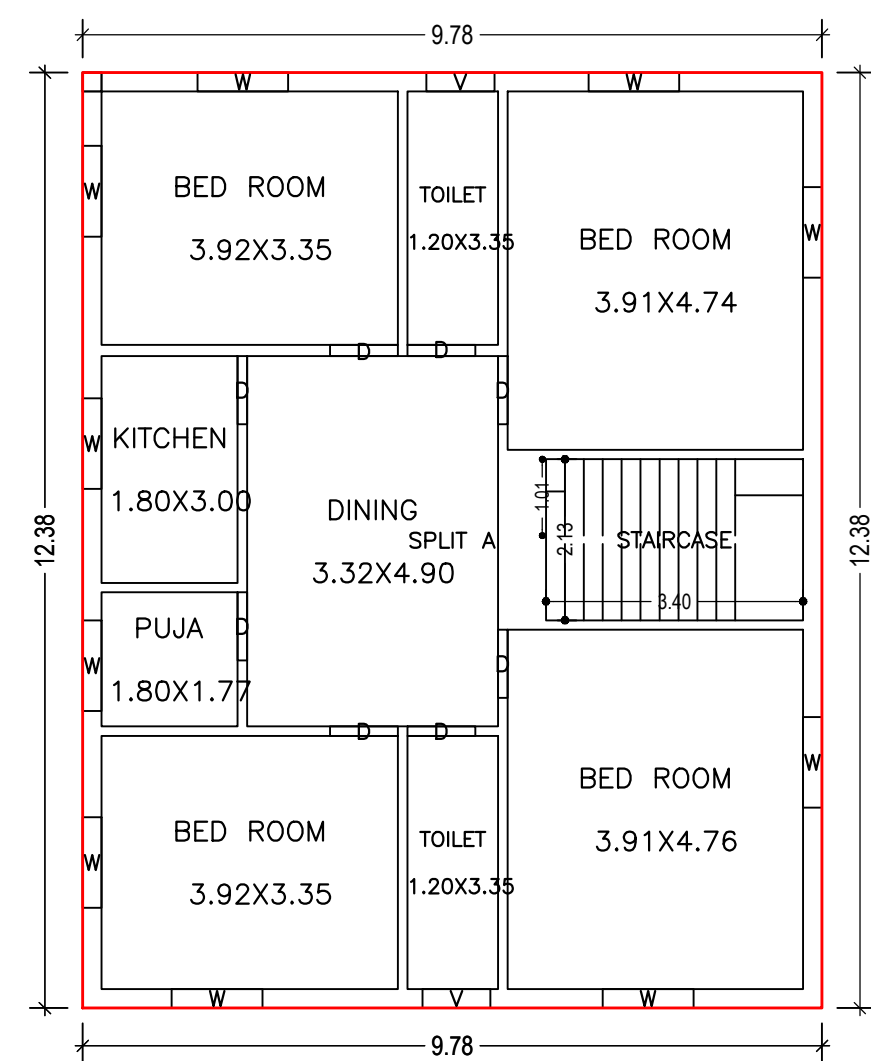

FIRST FLOOR PLAN (Proposed) (SCALE 1:100)

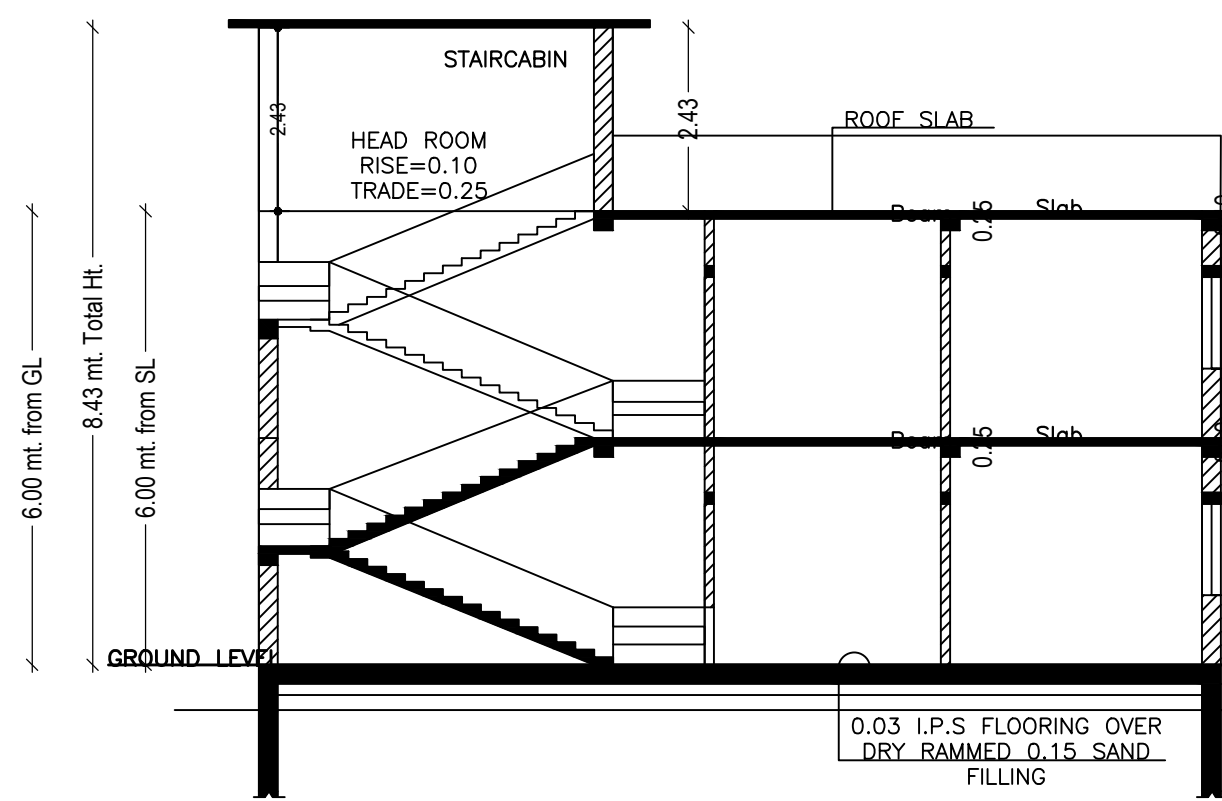

SECTION ON-XX

FRONT SIDE ELEVATION

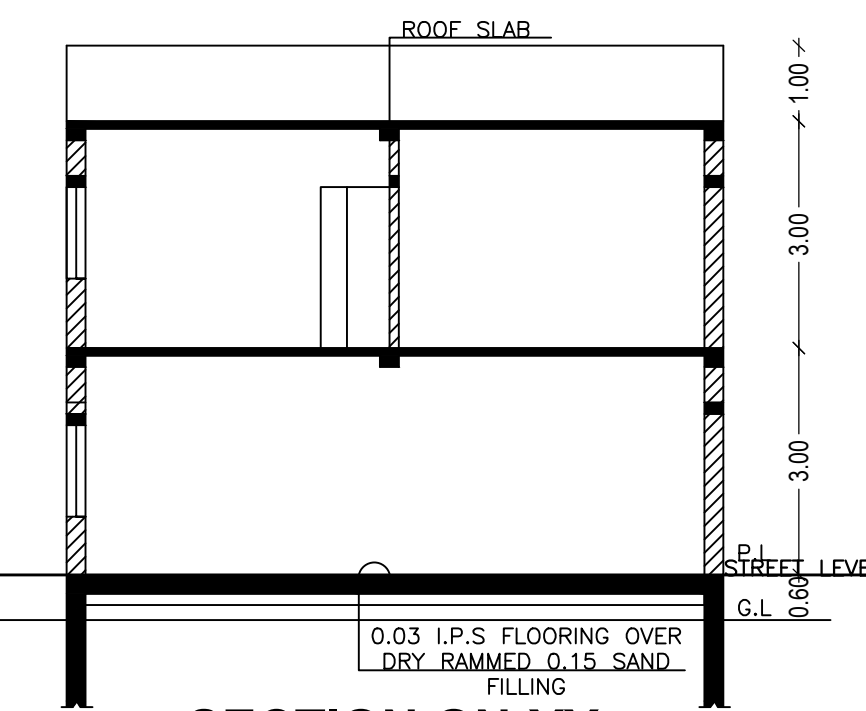

SECTION ON-YY

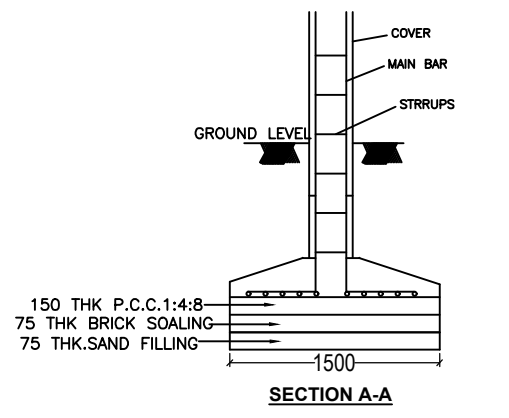
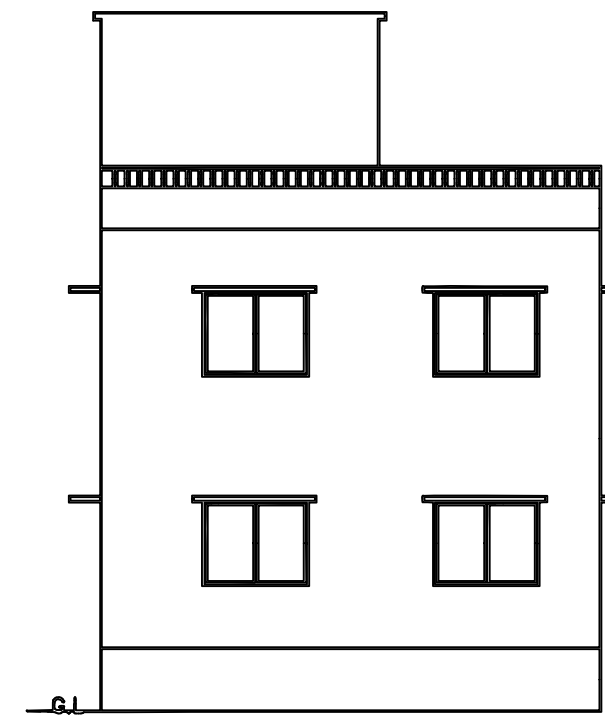

DETAIL OF FOUNDATION SCALE - N.T.S.

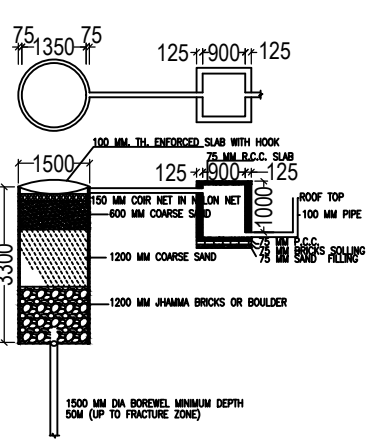

DETAIL OF GROUND WATER RECHARGING PIT WITH SILT TANK SCALE - N.T.S.

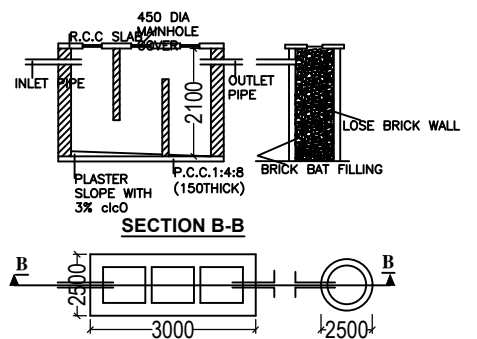

DETAIL OF SEPTIC TANK & SOAKPIT SCALE - 1:50

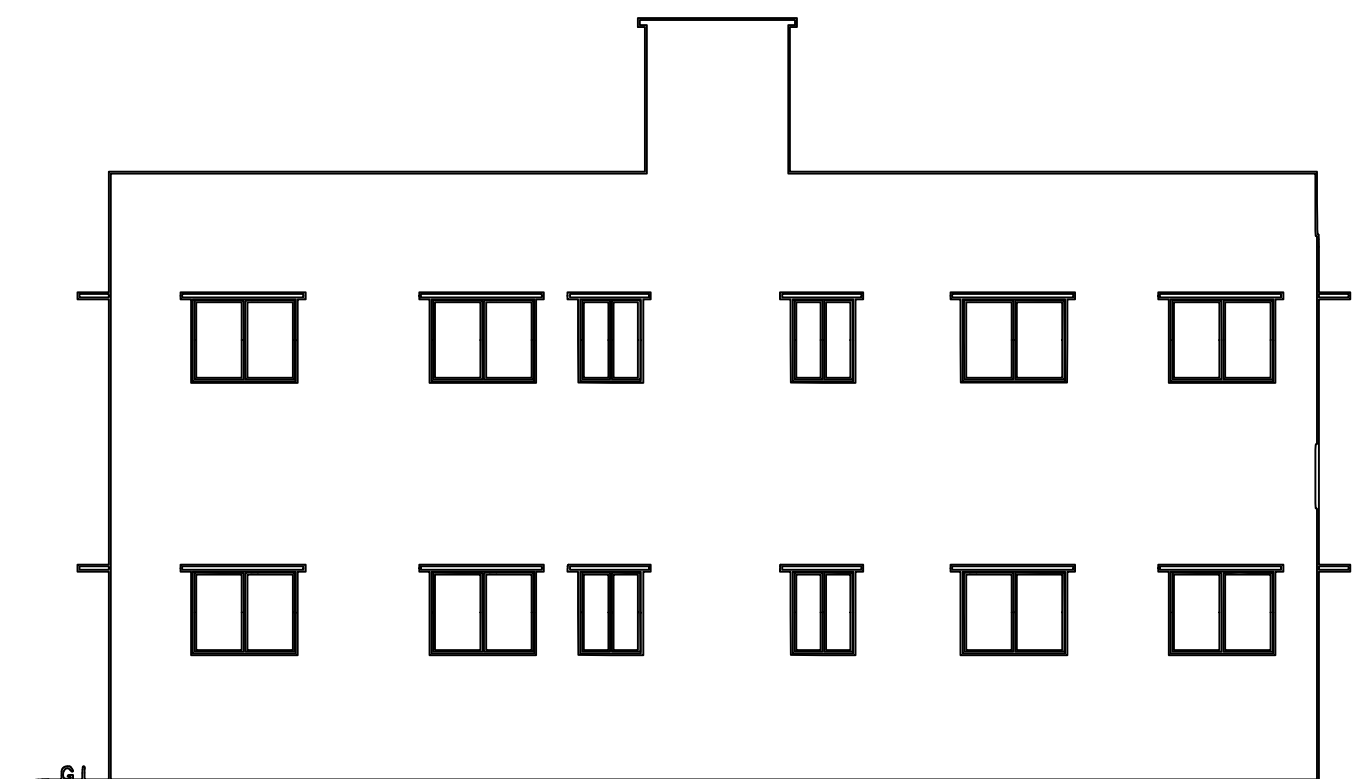

Building :A (BUILDING)

Floor Name	Total Built Up Area (Sq.mt.)	Proposed FAR Area (Sq.mt.) Resi.	Total FAR Area (Sq.mt.)	Total Consumed Additional FAR Area (Sq.mt.)	Tnmt (No.)
Ground Floor	121.03	121.03	121.03	121.03	01
First Floor	121.03	121.03	121.03	121.03	00
Terrace Floor	0.00	0.00	0.00	0.00	00
Total:	242.06	242.06	242.06	242.06	01
Total Number of Same Buildings	1				
Total:	242.06	242.06	242.06	242.06	01

SCHEDULE OF DOOR:

BUILDING NAME	NAME	LENGTH	HEIGHT	NOS
A (BUILDING)	D	0.90	2.10	14

SCHEDULE OF WINDOW/VENTILATION:

BUILDING NAME	NAME	LENGTH	HEIGHT	NOS
A (BUILDING)	V	0.90	0.60	03
A (BUILDING)	W	1.20	1.20	18

UnitBUA Table for Building :A (BUILDING)

FLOOR	Name	UnitBUA Type	UnitBUA Area	Carpet Area	No. of Rooms	No. of Tenement
FIRST FLOOR PLAN	SPLIT A	FLAT	0.00	0.00	9	0
GROUND FLOOR PLAN	SPLIT A	FLAT	226.51	226.38	6	1
Total:	-	-	226.51	226.38	15	1

LTP NAME AND SIGNATURE	STRUCTURAL ENG'S NAME AND SIGNATURE	BUILDER NAME AND SIGNATURE	DIGITAL SIGNATURE
MD ZAQUEALLAH MNNP/ENG/0002/2021			