

Proposal Basic Information

Proposal File No.	MNNP/IBP/0127/W/18/2023
Owner Name	Pappu Kumar
Khata No	32
Plot No	21
Village Name	Baralota
Use	Residential
SubUse	Bungalow/ Dwelling / Non Apartment

FAR & Tenement Details (Table 4c-1)

Building	No. of Same Bldg	Total Built Up Area (Sq.mt.)	Proposed FAR Area (Sq.mt.) Resi.	Total FAR Area (Sq.mt.)	Total Consumed Additional FAR Area (Sq.mt.)	Tnmt (No.)
A (RESIDENTIAL)	1	173.64	173.64	173.64	173.64	01
Grand Total :	1	173.64	173.64	173.64	173.64	01

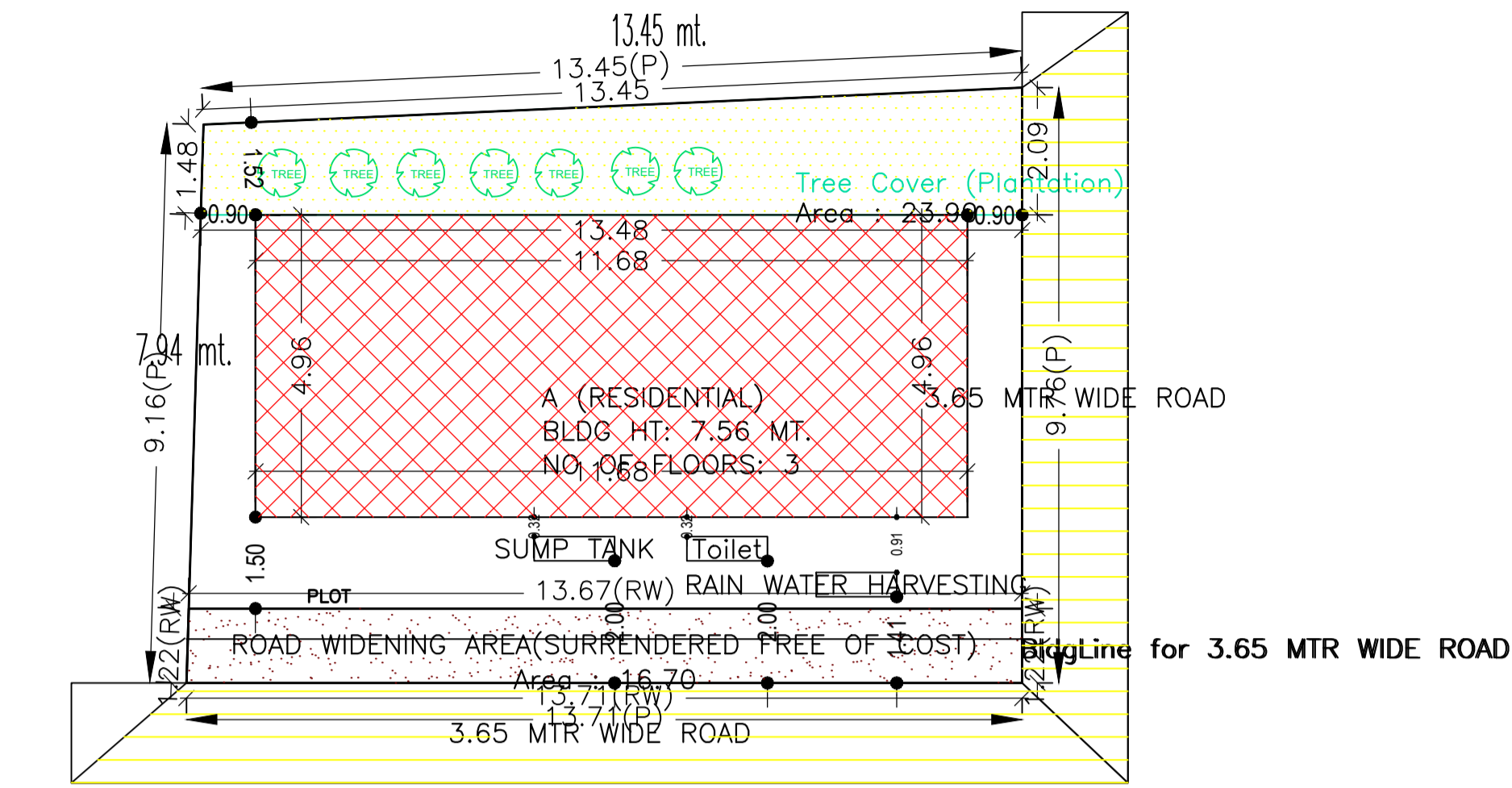

SITE PLAN

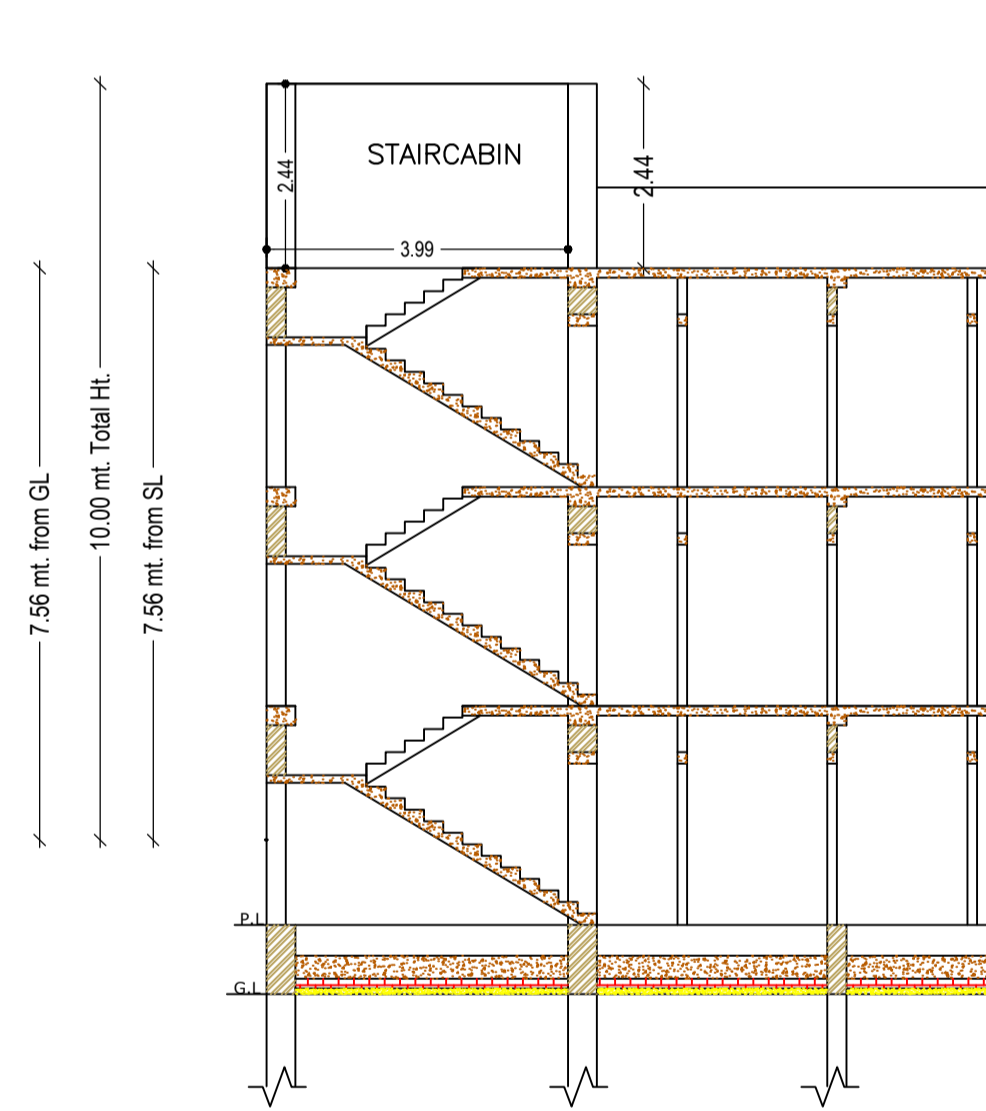
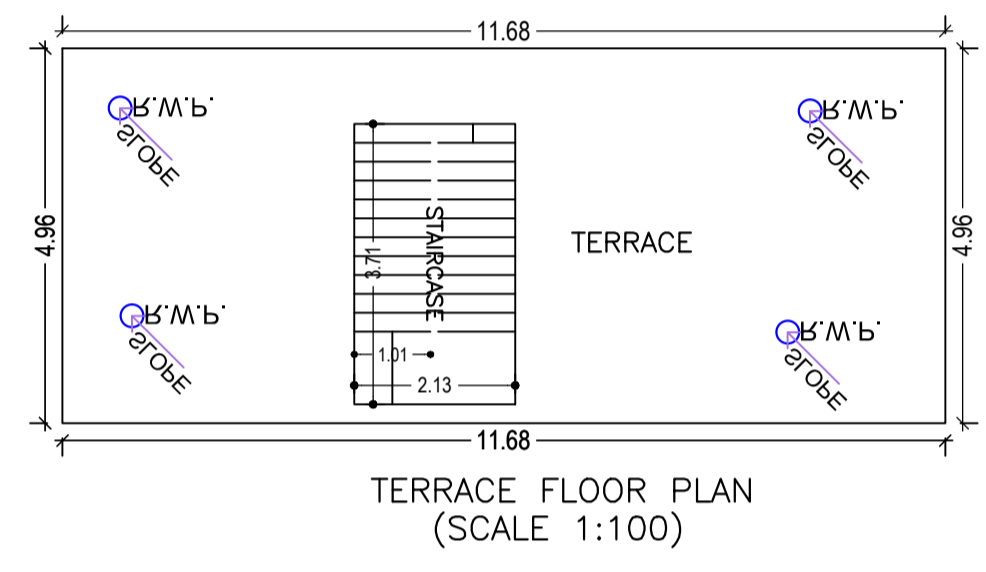
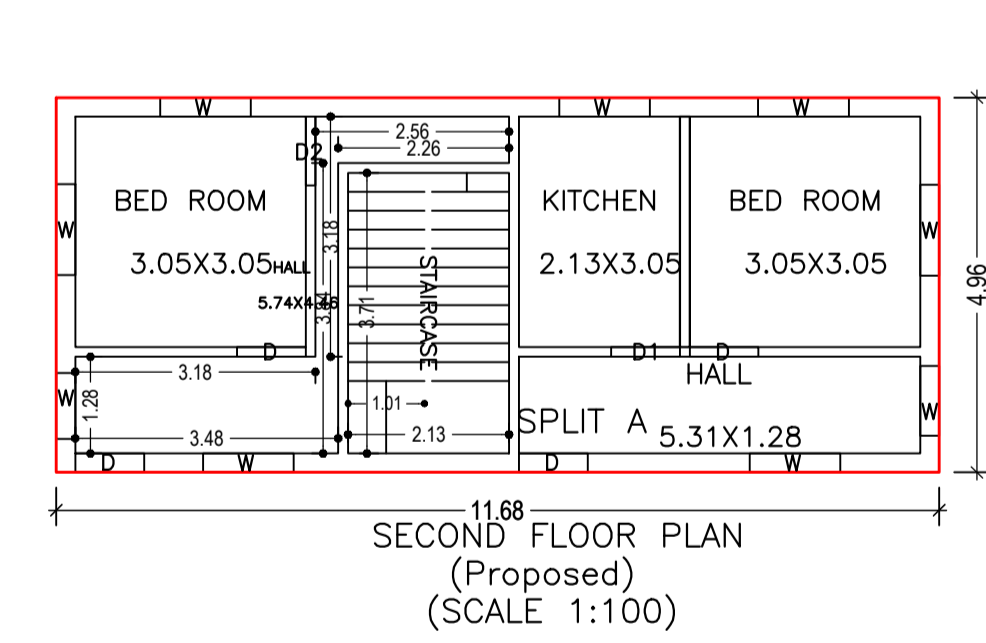
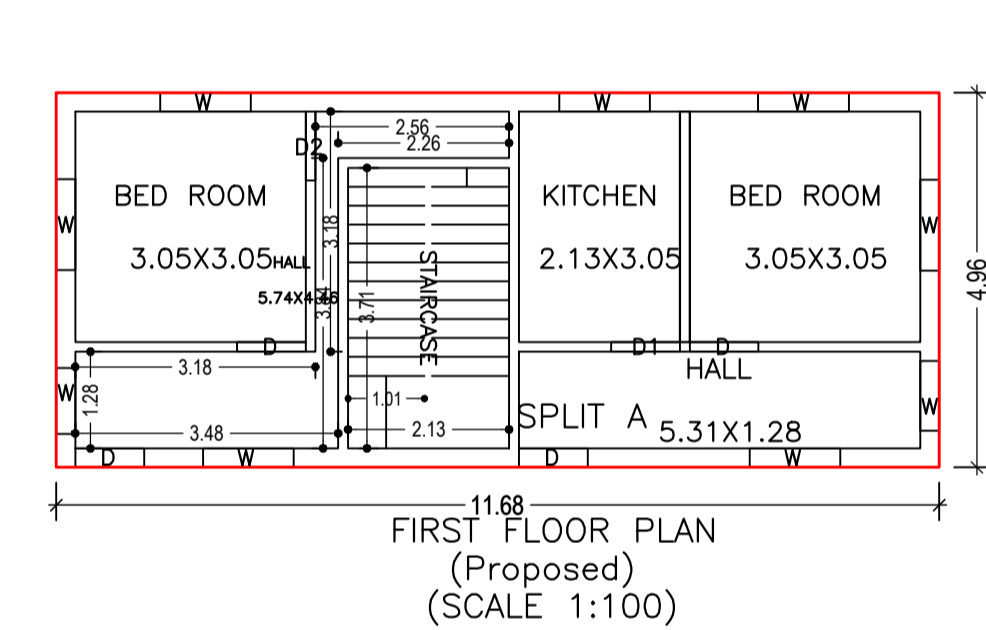
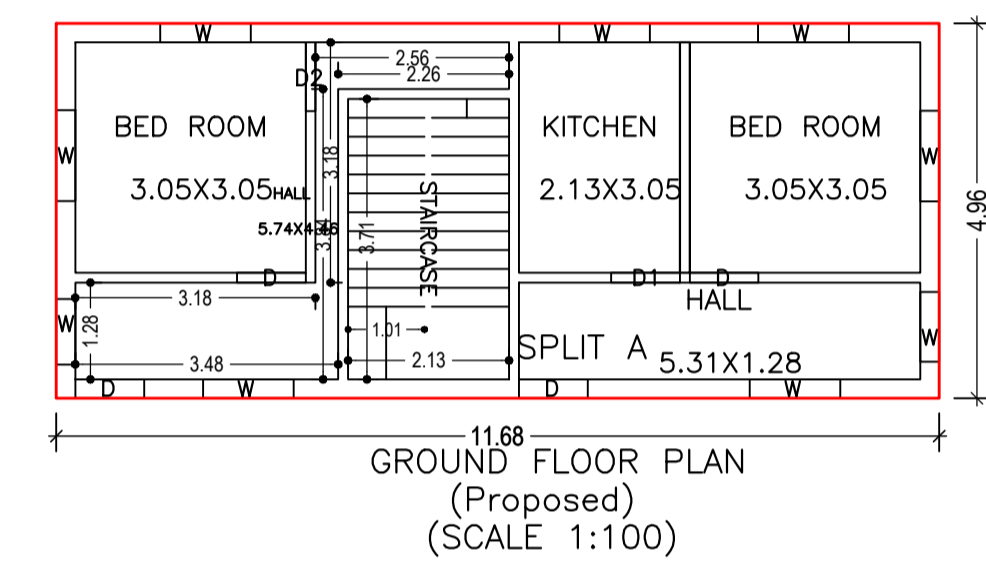

CROSS SECTION (A)

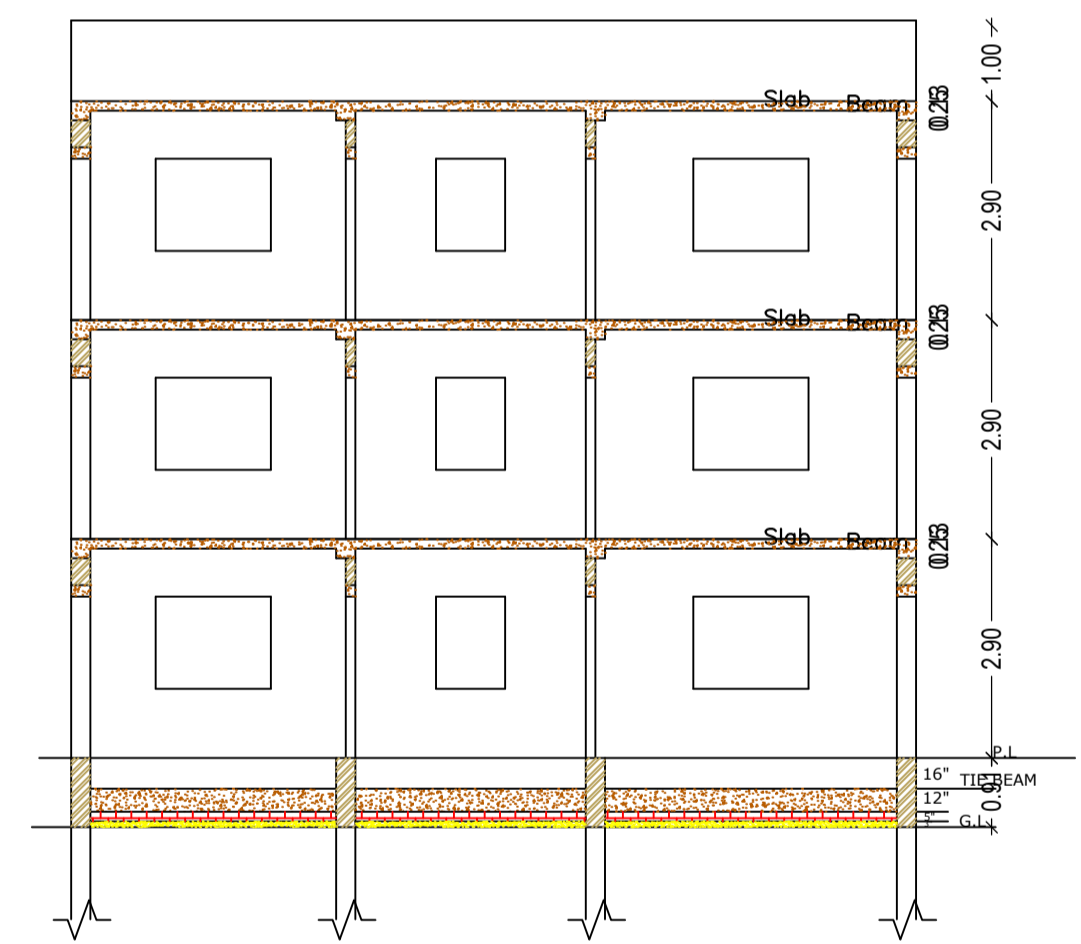

CROSS SECTION (B)

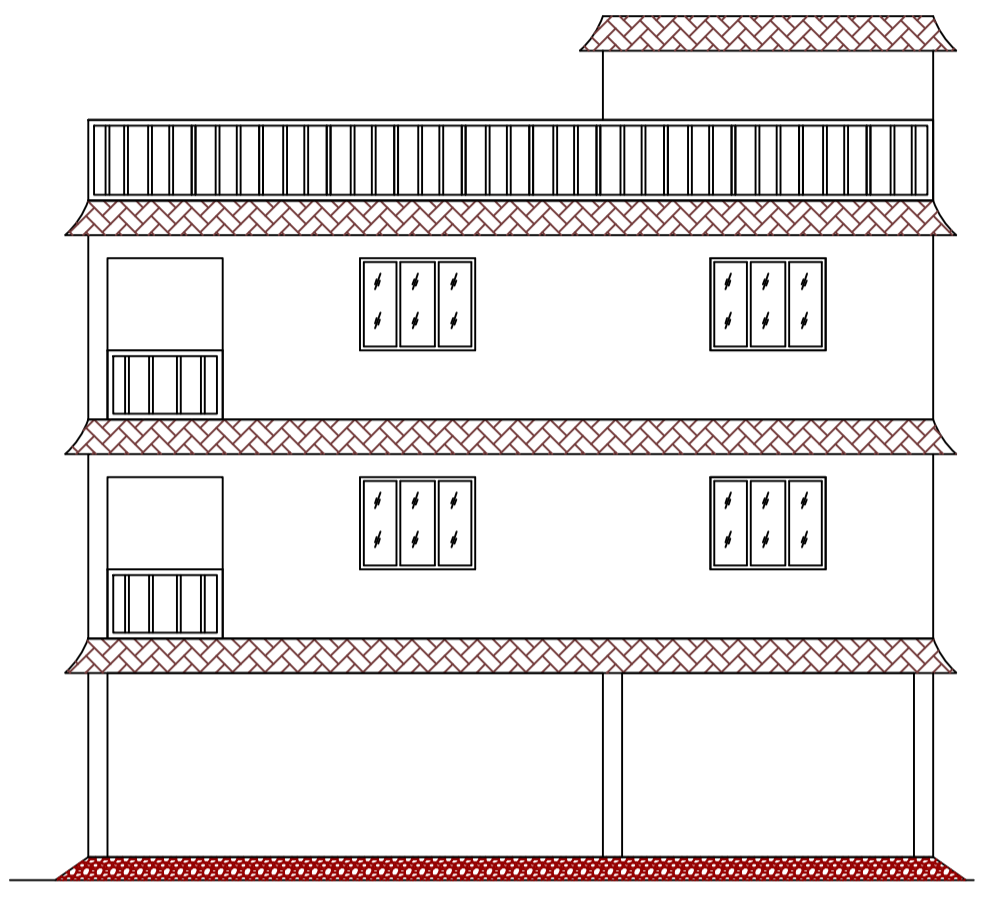

FRONT ELEVATION

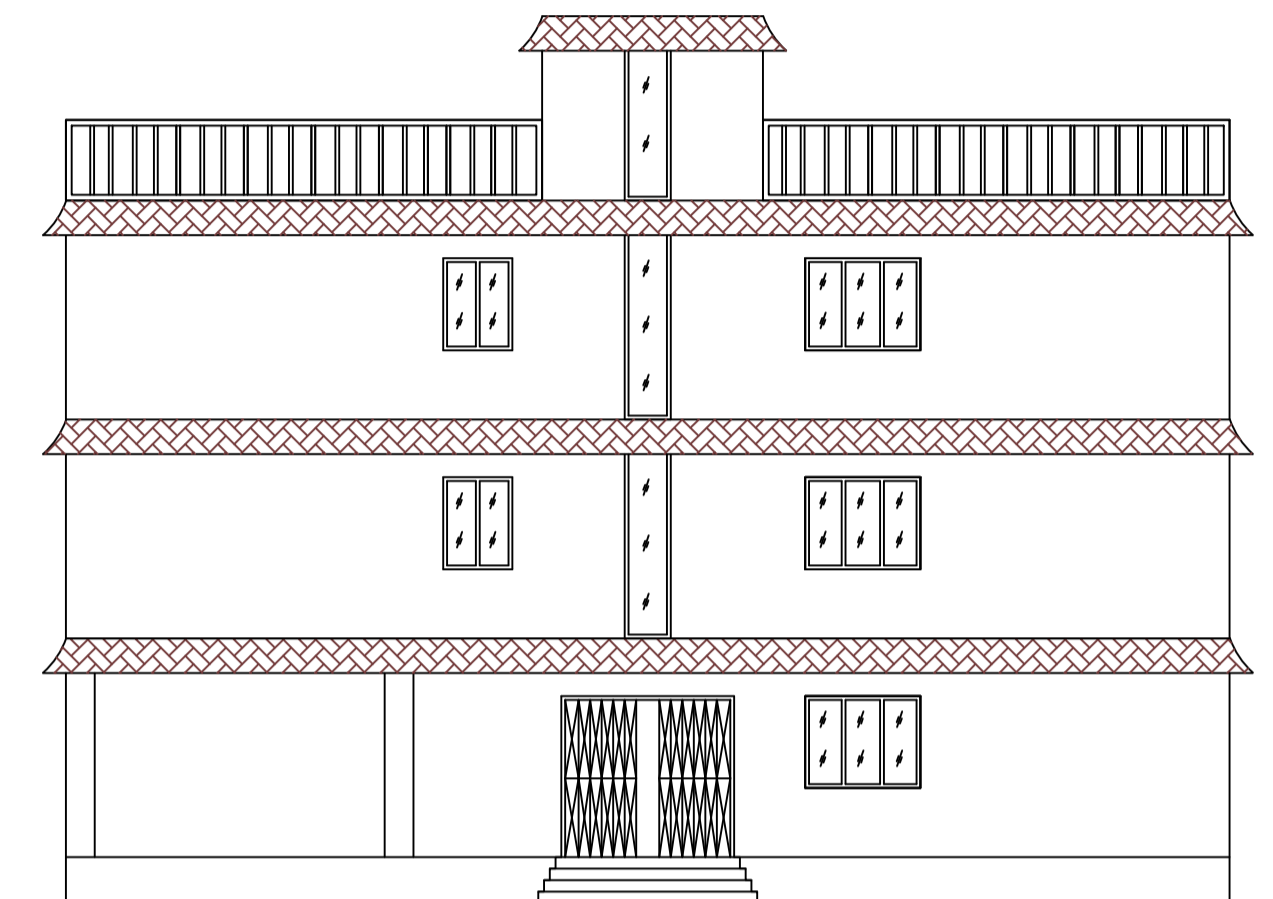

CROSS ELEVATION

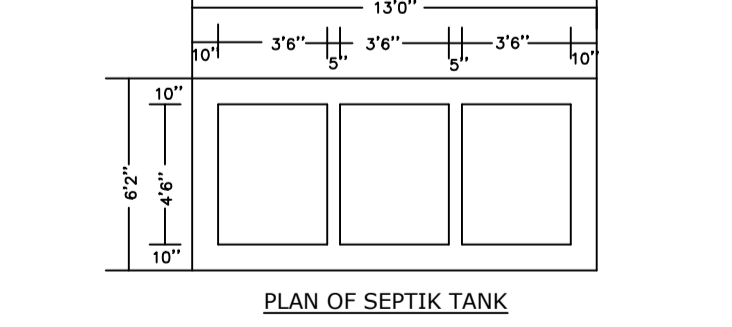
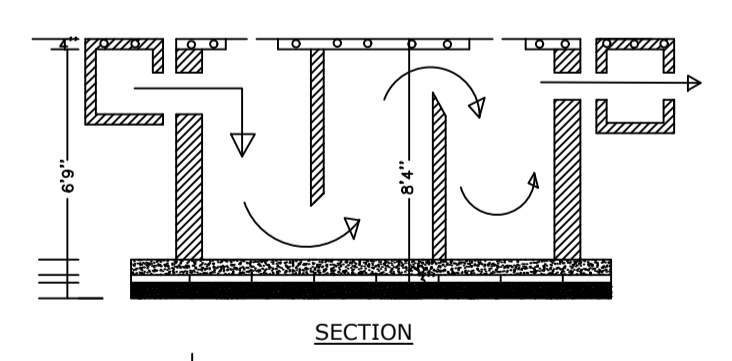
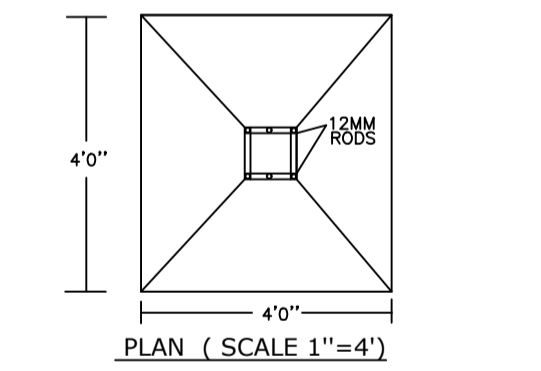
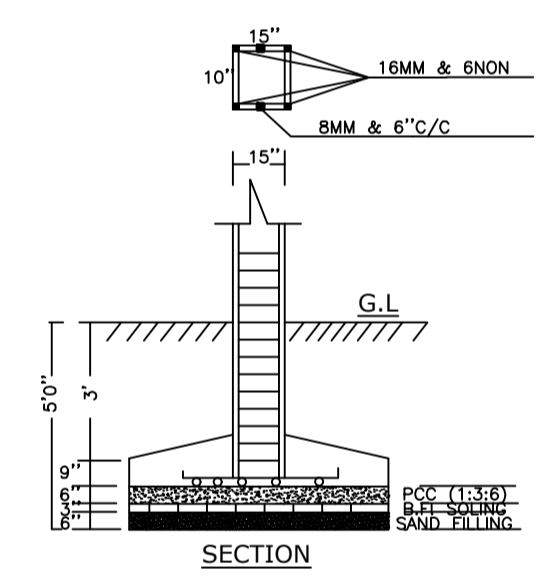

Building :A (RESIDENTIAL)

Floor Name	Total Built Up Area (Sq.mt.)	Proposed FAR Area (Sq.mt.) Resi.	Total FAR Area (Sq.mt.)	Total Consumed Additional FAR Area (Sq.mt.)	Tnmt (No.)
Ground Floor	57.88	57.88	57.88	57.88	01
First Floor	57.88	57.88	57.88	57.88	00
Second Floor	57.88	57.88	57.88	57.88	00
Terrace Floor	0.00	0.00	0.00	0.00	00
Total :	173.64	173.64	173.64	173.64	01
Total Number of Same Buildings	1				
Total :	173.64	173.64	173.64	173.64	01

SCHEDULE OF DOOR:

BUILDING NAME	NAME	LENGTH	HEIGHT	NOS
A (RESIDENTIAL)	D	0.91	2.10	12
A (RESIDENTIAL)	D2	0.91	2.10	03
A (RESIDENTIAL)	D1	0.91	2.10	03

SCHEDULE OF WINDOW/VENTILATION:

BUILDING NAME	NAME	LENGTH	HEIGHT	NOS
A (RESIDENTIAL)	W	0.87	1.20	03
A (RESIDENTIAL)	W	0.92	1.20	03
A (RESIDENTIAL)	W	1.20	1.20	21

UnitBUA Table for Building :A (RESIDENTIAL)

FLOOR	Name	UnitBUA Type	UnitBUA Area	Carpet Area	No. of Rooms	No. of Tenement
GROUND FLOOR PLAN	SPLIT A	FLAT	148.33	147.15	5	1
SECOND FLOOR PLAN	SPLIT A	FLAT	0.00	0.00	5	0
FIRST FLOOR PLAN	SPLIT A	FLAT	0.00	0.00	5	0
Total:	-	-	148.33	147.15	15	1

AREA STATEMENT

AREA DETAILS	SQ.MT.
AREA OF PLOT (Minimum)	(A) 128.25
Deduction for NetPlot Area	
Surrender Free of Cost	16.70
Total	16.70
NET AREA OF PLOT (Gross Plot Area - Deduction from Gross Plot area)	(A-Deductions) 111.55
Deduction for Balance Plot Area (from Gross Plot Area)	
Surrender Free of Cost	16.70
Common Plot	23.99
Total	40.69
BALANCE AREA OF PLOT (Net Plot Area - Recreational/Amenity space)	(A-Deductions) 87.56
PLOT AREA FOR COVERAGE (Net Plot Area)	(A-Deductions) 111.55
Plot Area for FAR (Net Plot Area + Road Widening Area)	(A-Deductions) 128.25

COVERAGE CHECK

Permissible Coverage area (70.00 %)	78.08
Proposed Coverage Area (51.89 %)	57.88
Total Prop. Coverage Area (51.89 %)	57.88
Balance coverage area (18.11 %)	20.20

FAR CHECK

Perm. FAR Area (1,500)	192.38
Total Perm. FAR area	192.38
Residential FAR	173.63
Proposed FAR Area	173.63
Total Proposed FAR Area	173.63
Consumed FAR (Factor)	1.35
Balance FAR Area	18.75

BUILT UP AREA CHECK

Total Proposed BuiltUp Area	173.64
-----------------------------	--------

ARCHITECT (Regd) RANJIT KUMAR
ENGINEER (Regd)
SUPERVISOR (Regd)
OWNER (Regd) Pappu Kumar

DEVELOPMENT AUTHORITY LOCAL BODY

COLOR INDEX

PLOT BOUNDARY	Black
ABUTTING ROAD	Green
PROPOSED CONSTRUCTION	Red
COMMON PLOT	Yellow
ROAD WIDENING AREA	Blue
EXISTING (To be retained)	Orange
EXISTING (To be demolished)	White

Buildingwise Floor FAR Details

Floor Name	Building Name A (RESIDENTIAL)		Total	
	Proposed Built Up Area (Sq.mt.)	Proposed FAR Area (Sq.mt.)	Total Proposed Built Up Area (Sq.mt.)	Total FAR Area (Sq.mt.)
Ground Floor	57.88	57.88	57.88	57.88
First Floor	57.88	57.88	57.88	57.88
Second Floor	57.88	57.88	57.88	57.88
Terrace Floor	0.00	0.00	0.00	0.00
Total :	173.64	173.64	173.64	173.64

Building USE/SUBUSE Details

Building Name	Building Use	Building SubUse	Building Structure
A (RESIDENTIAL)	Residential	Bungalow/ Dwelling / Non Apartment	Non-Highrise

LTP NAME AND SIGNATURE	STRUCTURAL ENG'S NAME AND SIGNATURE	BUILDER NAME AND SIGNATURE	DIGITAL SIGNATURE
RANJIT KUMAR MNNP/ENG/0001/2016			