

FAR & Tenement Details (Table 4c-1)

Building	No. of Same Bldg	Total Built Up Area (Sq.mt.)	Proposed FAR Area (Sq.mt.) Resi.	Total FAR Area (Sq.mt.)	Total Consumed Additional FAR Area (Sq.mt.)	Tnmt (No.)
A (RESIDENTIAL)	1	179.80	179.80	179.80	179.80	01
Grand Total :	1	179.80	179.80	179.80	179.80	01

Proposal Basic Information

Proposal File No.	MNNP/BP/0037/W03/2023
Owner Name	Shyam Lal Gupta
Khata No	26
Plot No	12
Village Name	Nimiya
Use	Residential
SubUse	Bungalow/ Dwelling / Non Apartment

AREA STATEMENT

AREA DETAILS	SQ.MT.
AREA OF PLOT (Minimum)	181.60
Deduction for NetPlot Area	
Surrender Free of Cost	15.05
Total	15.05
NET AREA OF PLOT (Gross Plot Area - Deduction from Gross Plot area)	166.55
Deduction for Balance Plot Area (from Gross Plot Area)	
Surrender Free of Cost	15.05
Common Plot	18.35
Total	33.40
BALANCE AREA OF PLOT (Net Plot Area - Recreational/Amenity space)	148.20
PLOT AREA FOR COVERAGE (Net Plot Area)	166.55
Plot Area for FAR (Net Plot Area + Road Widening Area)	181.60

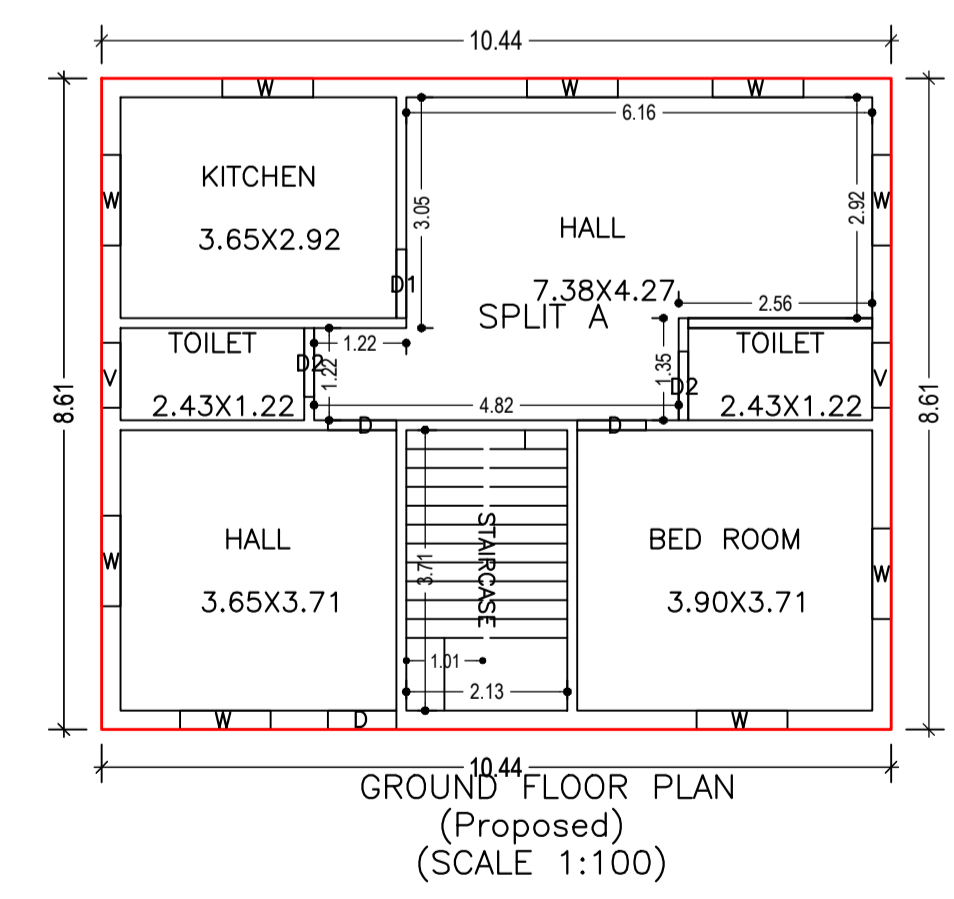
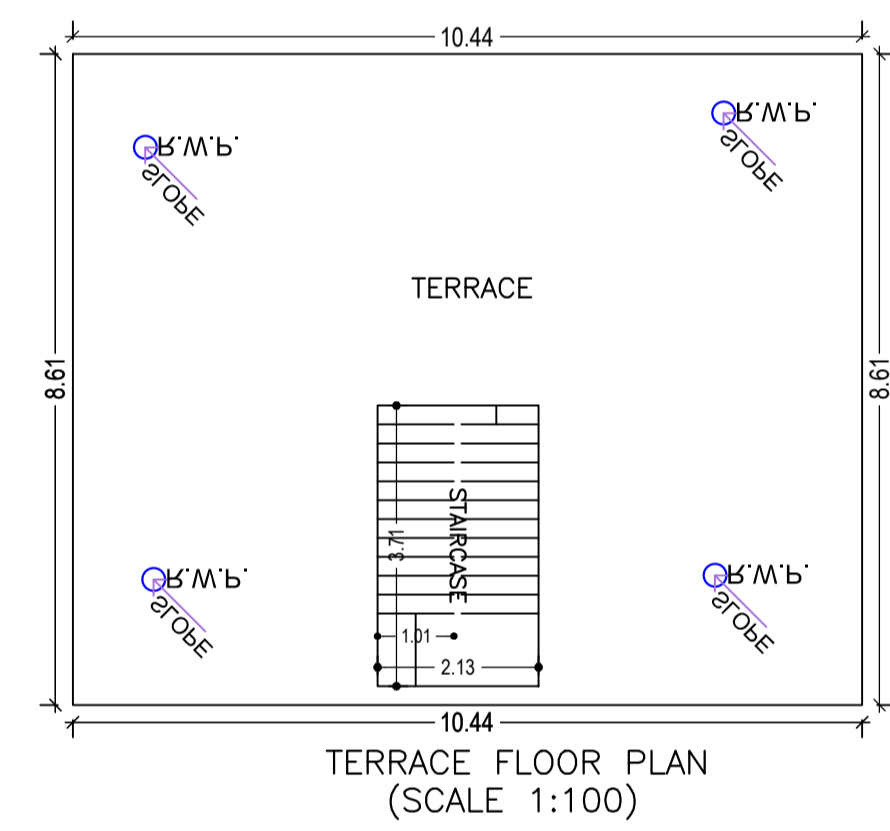
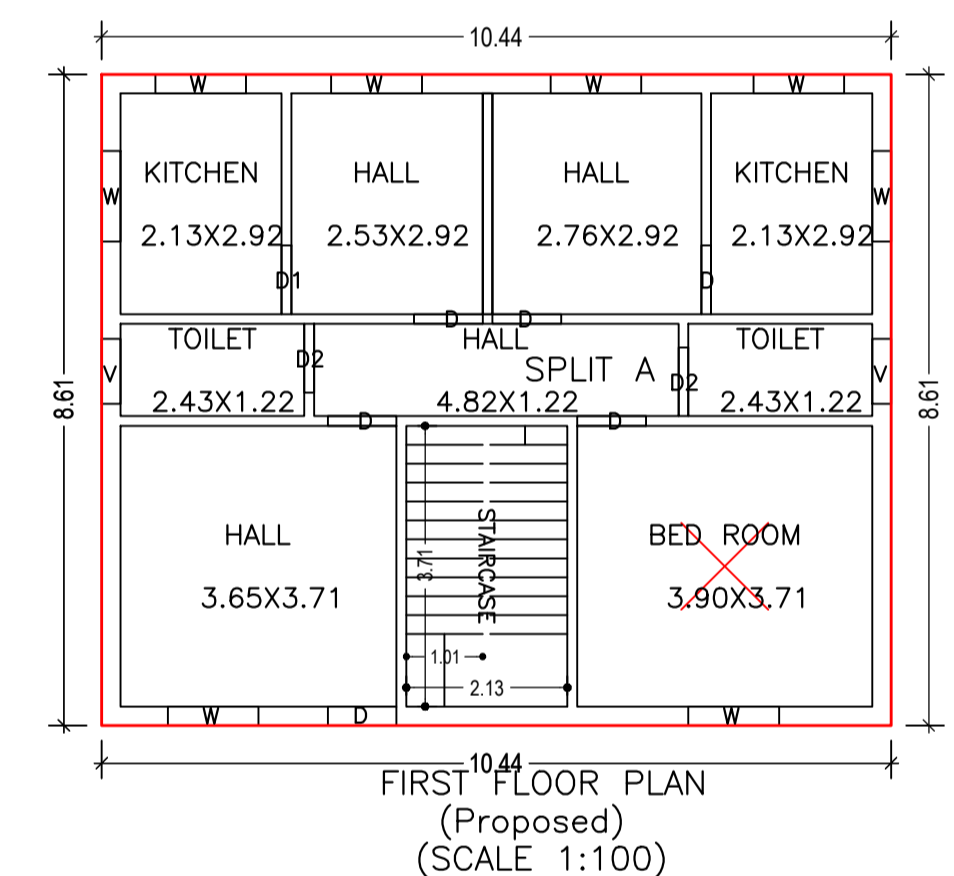

Building :A (RESIDENTIAL)

Floor Name	Total Built Up Area (Sq.mt.)	Proposed FAR Area (Sq.mt.) Resi.	Total FAR Area (Sq.mt.)	Total Consumed Additional FAR Area (Sq.mt.)	Tnmt (No.)
Ground Floor	89.90	89.90	89.90	89.90	01
First Floor	89.90	89.90	89.90	89.90	00
Terrace Floor	0.00	0.00	0.00	0.00	00
Total :	179.80	179.80	179.80	179.80	01
Total Number of Same Buildings	1				
Total :	179.80	179.80	179.80	179.80	01

SCHEDULE OF DOOR:

BUILDING NAME	NAME	LENGTH	HEIGHT	NOS
A (RESIDENTIAL)	D1	0.91	2.10	02
A (RESIDENTIAL)	D	0.91	2.10	09
A (RESIDENTIAL)	D2	0.91	2.10	04

SCHEDULE OF WINDOW/VENTILATION:

BUILDING NAME	NAME	LENGTH	HEIGHT	NOS
A (RESIDENTIAL)	V	0.86	0.90	04
A (RESIDENTIAL)	W	1.20	1.20	17

UnitBUA Table for Building :A (RESIDENTIAL)

FLOOR	Name	UnitBUA Type	UnitBUA Area	Carpet Area	No. of Rooms	No. of Tenement
FIRST FLOOR PLAN	SPLIT A	FLAT	0.00	0.00	9	0
GROUND FLOOR PLAN	SPLIT A	FLAT	162.92	162.23	6	1
Total:	-	-	162.92	162.23	15	1

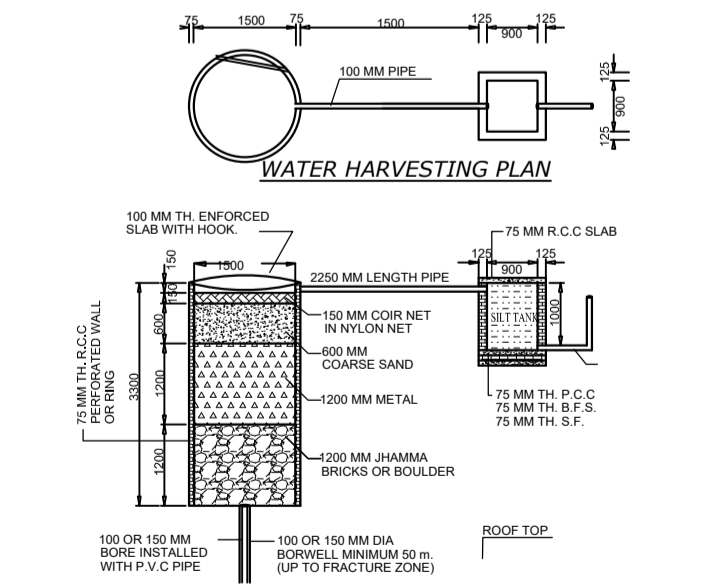
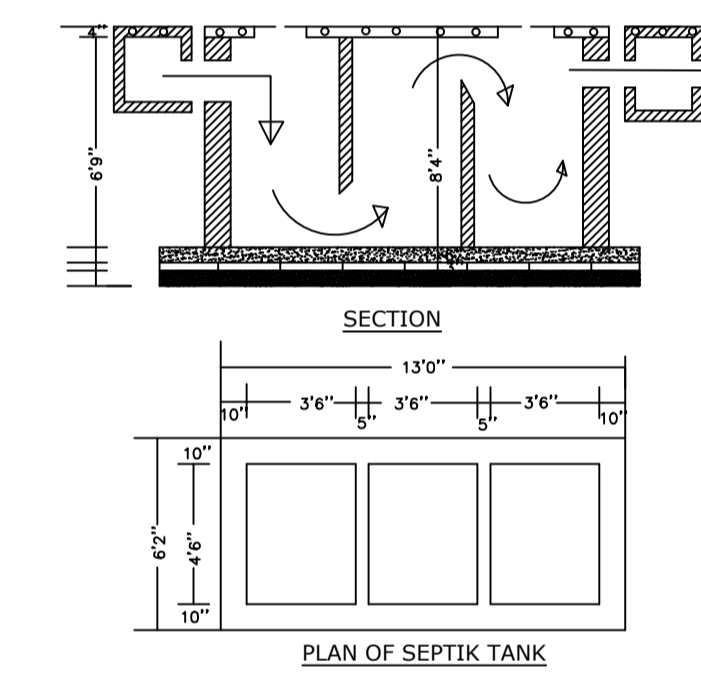
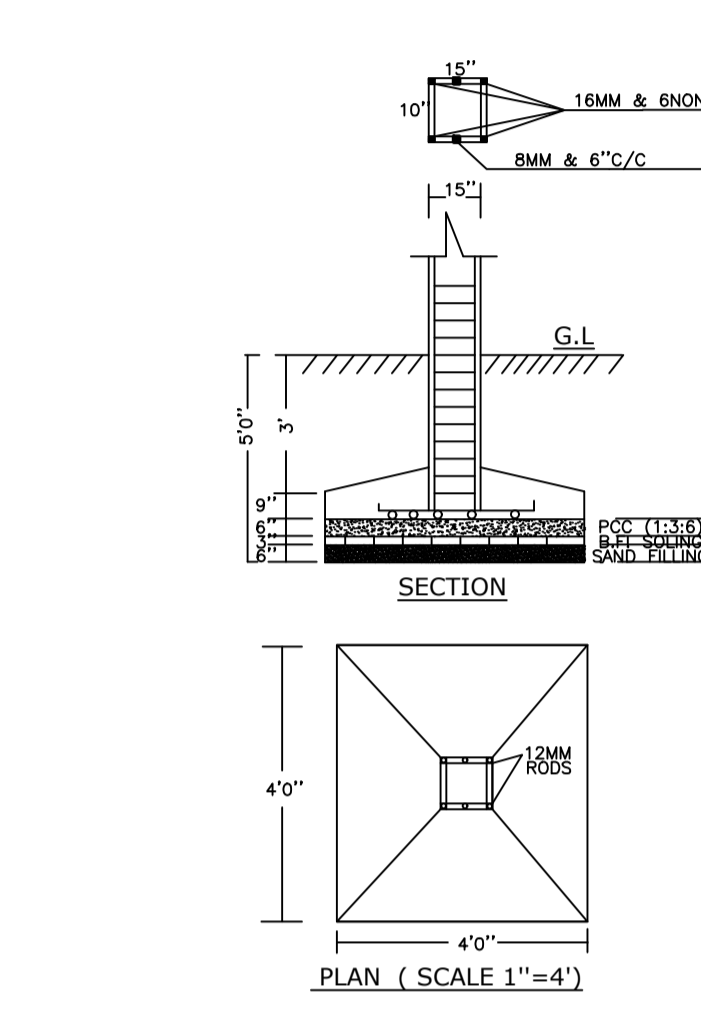

COVERAGES CHECK

COVERAGES CHECK	PERMISSIBLE	PROPOSED	TOTAL PROP.	BALANCE
Permissible Coverage area ( 70.00 % )	116.58			
Proposed Coverage Area ( 53.98 % )		89.90		
Total Prop. Coverage Area ( 53.98 % )			89.90	
Balance coverage area ( 16.02 % )				26.68

FAR CHECK

FAR CHECK	PERM. FAR AREA ( 1.500 )	TOTAL PERM. FAR AREA	RESIDENTIAL FAR	PROPOSED FAR AREA	TOTAL PROPOSED FAR AREA	CONSUMED FAR (FACTOR)	BALANCE FAR AREA
Perm. FAR Area ( 1.500 )	272.40						
Total Perm. FAR area		272.40					
Residential FAR			179.79				
Proposed FAR Area				179.79			
Total Proposed FAR Area					179.79		
Consumed FAR (Factor)						0.99	
Balance FAR Area							92.61

BUILT UP AREA CHECK

BUILT UP AREA CHECK	TOTAL PROPOSED BUILT UP AREA
Total Proposed BuiltUp Area	179.80

ARCHITECT (Regd) RANJIT KUMAR  
ENGINEER (Regd)  
SUPERVISOR (Regd)  
OWNER (Regd) Shyam Lal Gupta

DEVELOPMENT AUTHORITY LOCAL BODY

COLOR INDEX

DESCRIPTION	COLOR
PLOT BOUNDARY	Black
ABUTTING ROAD	Green
PROPOSED CONSTRUCTION	Red
COMMON PLOT	Yellow
ROAD WIDENING AREA	Blue
EXISTING (To be retained)	Orange
EXISTING (To be demolished)	White

Buildingwise Floor FAR Details

Floor Name	Building Name A (RESIDENTIAL)		Total	
	Proposed Built Up Area (Sq.mt.)	Proposed FAR Area (Sq.mt.)	Total Proposed Built Up Area (Sq.mt.)	Total FAR Area (Sq.mt.)
Ground Floor	89.90	89.90	89.90	89.90
First Floor	89.90	89.90	89.90	89.90
Terrace Floor	0.00	0.00	0.00	0.00
Total :	179.80	179.80	179.80	179.80

Building USE/SUBUSE Details

Building Name	Building Use	Building SubUse	Building Structure
A (RESIDENTIAL)	Residential	Bungalow/ Dwelling / Non Apartment	Non-Highrise

LTP NAME AND SIGNATURE	STRUCTURAL ENG'S NAME AND SIGNATURE	BUILDER NAME AND SIGNATURE	DIGITAL SIGNATURE
RANJIT KUMAR MNNP/ENG/0001/2016			