

Proposal Basic Information	
Proposal File No.	MNNP/BP/0044/W04/2023
Owner Name	DHANI SAW
Khata No	00
Plot No	466,469
Village Name	Kundh
Use	Residential
SubUse	Bungalow/ Dwelling / Non Apartment

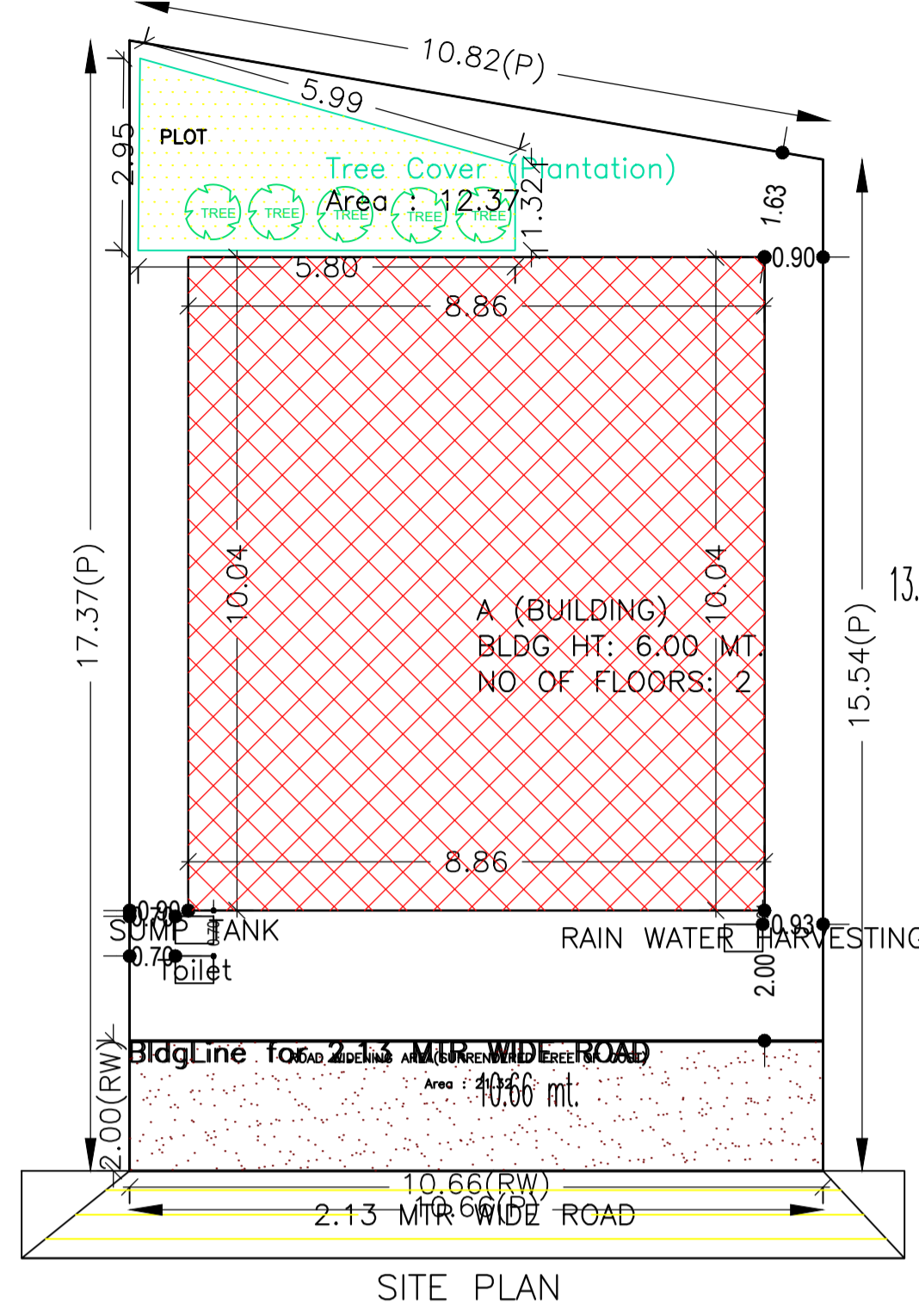

13.54 mt. 7.00 mt. long 1.00 mt. High 3.60 mt. Wide Ramp

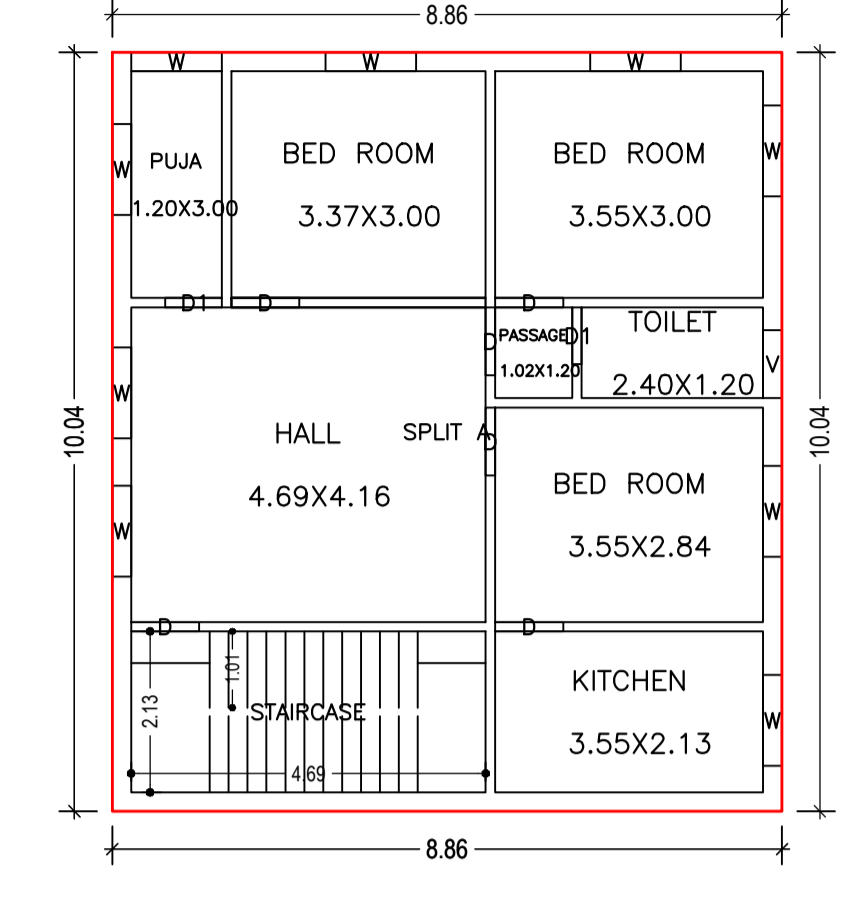
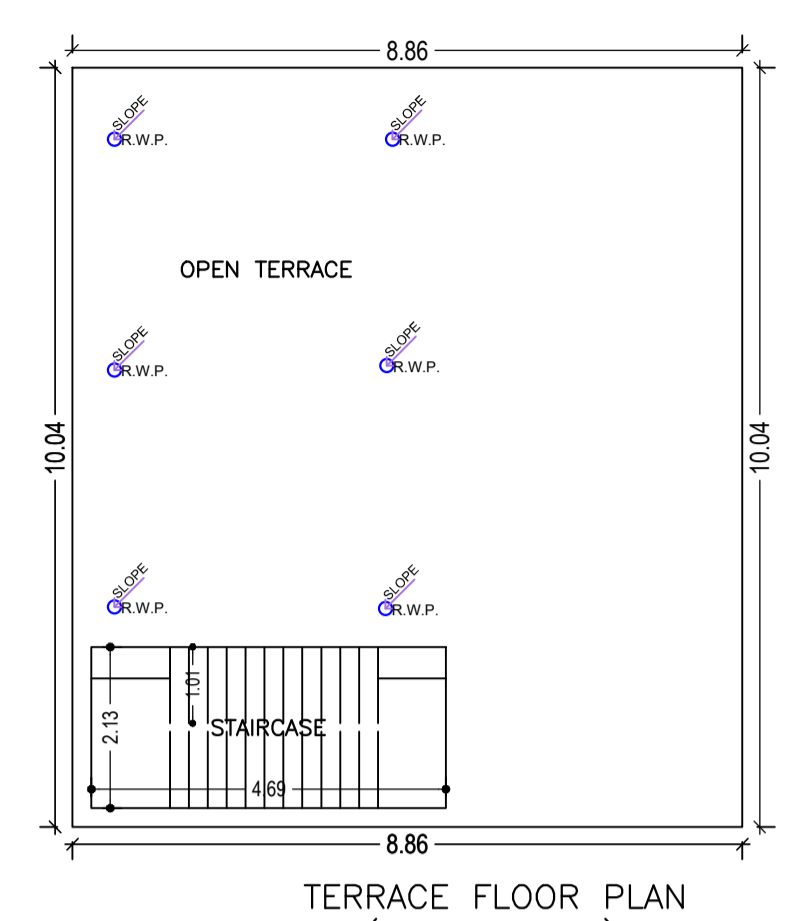
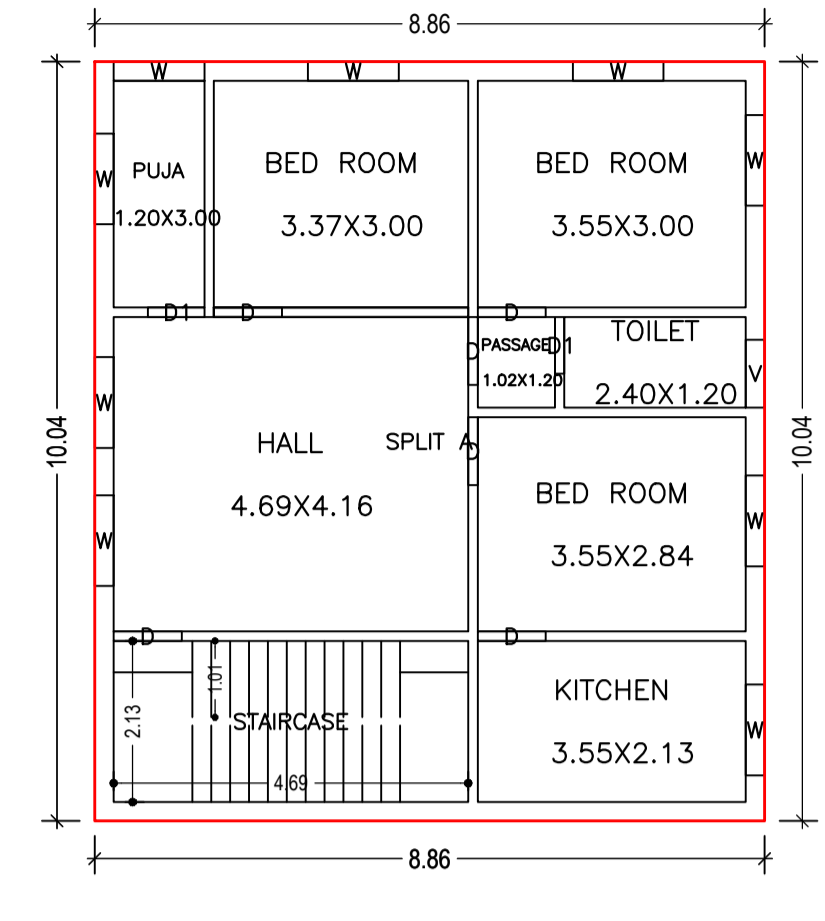
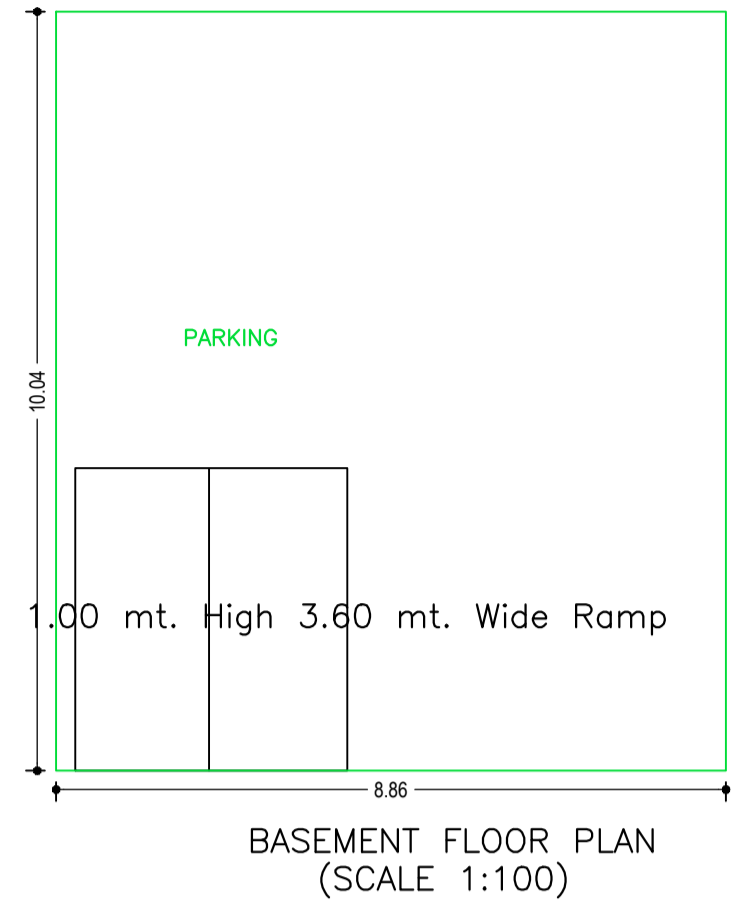

Building :A (BUILDING)

Floor Name	Total Built Up Area (Sq.mt.)	Deductions (Area in Sq.mt.)	Proposed FAR Area (Sq.mt.)	Total FAR Area (Sq.mt.)	Total Consumed Additional FAR Area (Sq.mt.)	Tnmt (No.)
Basement Floor	88.95	74.55	0.00	0.00	0.00	00
Ground Floor	88.95	0.00	88.95	88.95	88.95	01
First Floor	88.95	0.00	88.95	88.95	88.95	00
Terrace Floor	0.00	0.00	0.00	0.00	0.00	00
Total :	266.85	74.55	177.90	177.90	177.90	01
Total Number of Same Buildings	1					
Total :	266.85	74.55	177.90	177.90	177.90	01

SCHEDULE OF DOOR:

BUILDING NAME	NAME	LENGTH	HEIGHT	NOS
A (BUILDING)	D1	0.75	2.10	04
A (BUILDING)	D	0.90	2.10	12

SCHEDULE OF WINDOW/VENTILATION:

BUILDING NAME	NAME	LENGTH	HEIGHT	NOS
A (BUILDING)	V	0.90	0.60	02
A (BUILDING)	W	1.20	1.20	18

UnitBUA Table for Building :A (BUILDING)

FLOOR	Name	UnitBUA Type	UnitBUA Area	Carpet Area	No. of Rooms	No. of Tenement
GROUND FLOOR PLAN	SPLIT A	FLAT	154.39	153.55	8	1
FIRST FLOOR PLAN	SPLIT A	FLAT	0.00	0.00	8	0
Total:			154.39	153.55	16	1

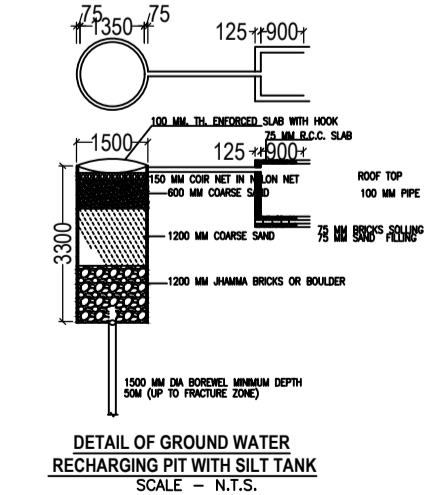
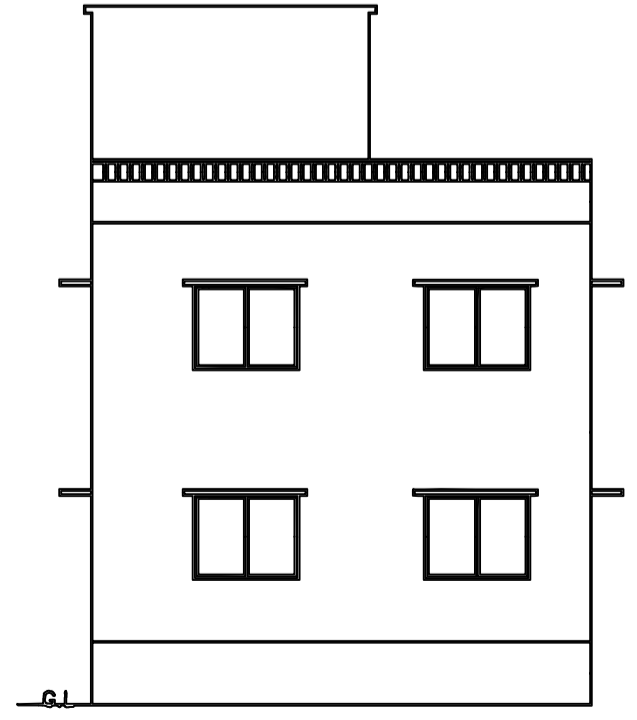
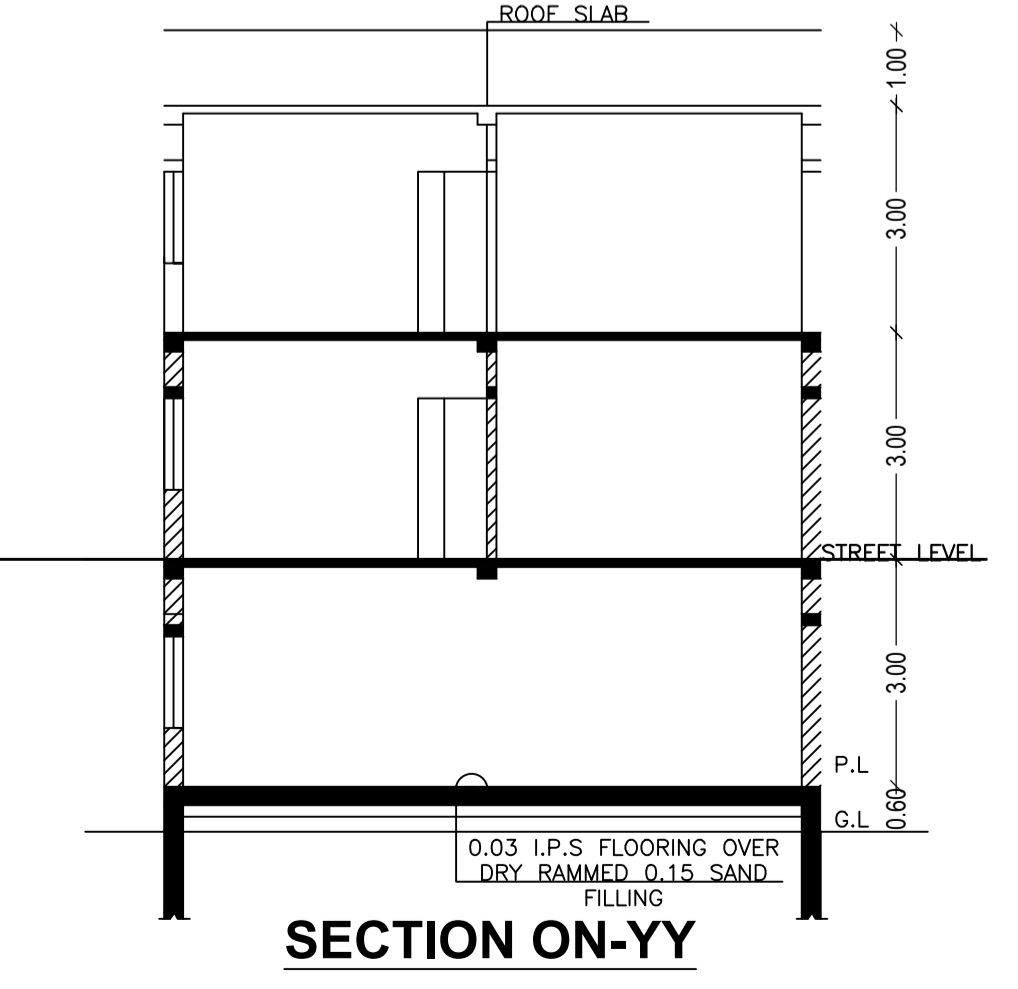
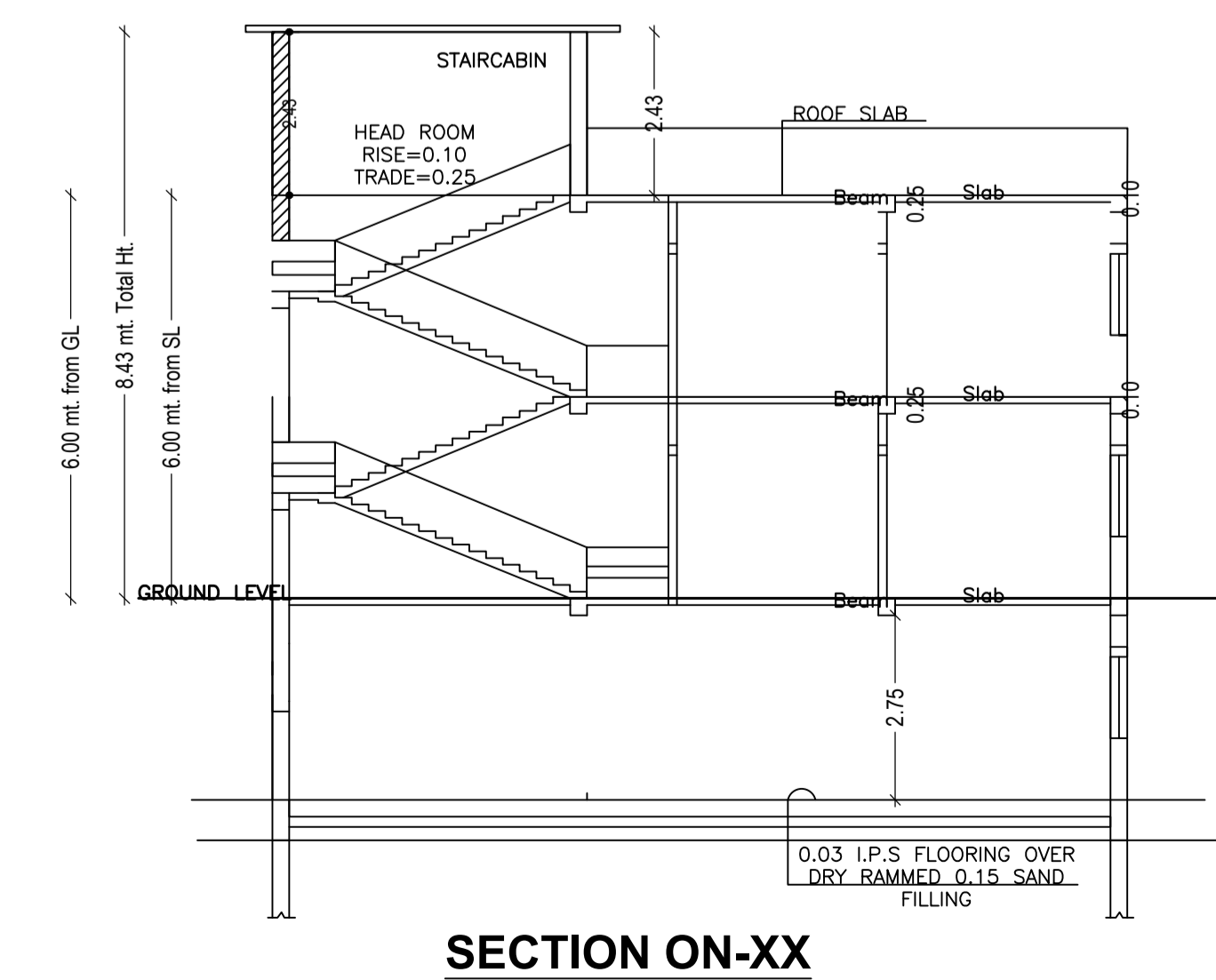
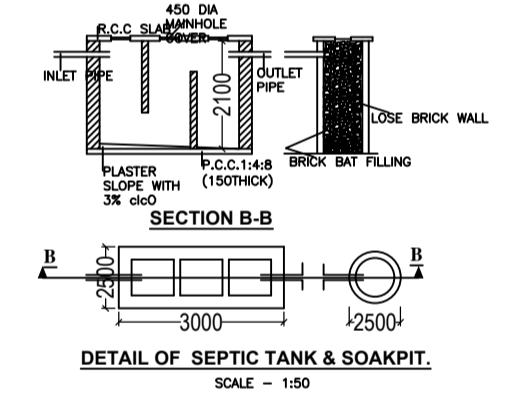
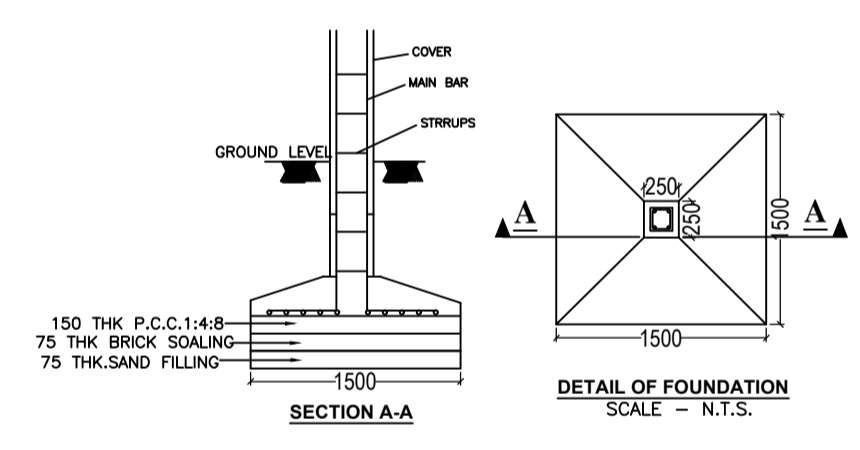
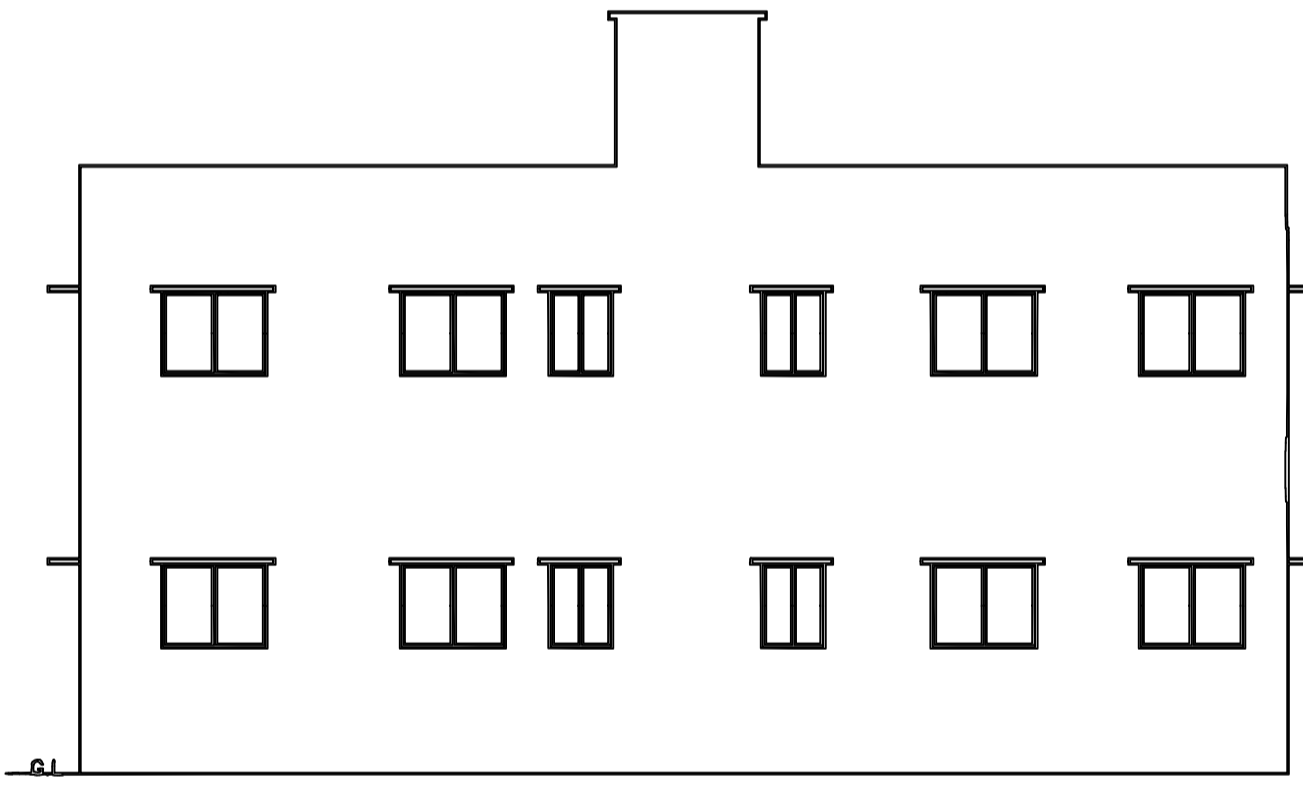

AREA STATEMENT		VERSION NO.:	1.0.66
MEDININAGAR MUNICIPAL CORPORATION		VERSION DATE:	16/10/2020
PROJECT DETAIL:			
Region: JHARKHAND URBAN LOCAL BODIES	Plot Use:	Residential	
District: PALAMU	Plot SubUse:	Bungalow/ Dwelling / Non Apartment	
Authority: MEDININAGAR MUNICIPAL CORPORATION	PlotNearbyReligiousStructure:	NA	
Inward No: MNNP/BP/0044/W04/2023	Plot/SubPlot No:	466,469	
Application Type: General Proposal	North:	-	
Project Type: Building Permission	South:	-	
Nature of Development: New	East:	-	
Location of Development Area: New Area	West:	-	
AREA DETAILS:			
AREA OF PLOT (Minimum)	(A)		SQ.MT. 175.41
Deduction for NetPlot Area			
Surrender Free of Cost			21.32
Total			21.32
NET AREA OF PLOT(Gross Plot Area - Deduction from Gross Plot area)	(A-Deductions)		154.09
Deduction for Balance Plot Area(from Gross Plot Area)			
Surrender Free of Cost			21.32
Common Plot			12.37
Total			33.69
BALANCE AREA OF PLOT(Net Plot Area - Recreational/Amenity space)	(A-Deductions)		141.73
PLOT AREA FOR COVERAGE(Net Plot Area)	(A-Deductions)		154.09
Plot Area for FAR (Net Plot Area + RoadWidening Area)	(A-Deductions)		175.41
COVERAGE CHECK			
Permissible Coverage area (70.00 %)			107.86
Proposed Coverage Area (57.73 %)			88.95
Total Prop. Coverage Area (57.73 %)			88.95
Balance coverage area (12.27 %)			18.91
FAR CHECK			
Perm. FAR Area (1,200)			210.49
Total Perm. FAR area			210.49
Residential FAR			177.91
Proposed FAR Area			177.91
Total Proposed FAR Area			177.91
Consumed FAR (Factor)			1.01
Balance FAR Area			32.58
BUILT UP AREA CHECK			
Total Proposed BuiltUp Area			266.85
ARCHITECT (Regd)	PANKAJ KUMAR SINGH		
ENGINEER (Regd)	DHANI SAW		
SUPERVISOR (Regd)	DHANI SAW		
OWNER (Regd)	DHANI SAW		
DEVELOPMENT AUTHORITY		LOCAL BODY	

COLOR INDEX

PLOT BOUNDARY	Black
ABUTTING ROAD	Green
PROPOSED CONSTRUCTION	Red
COMMON PLOT	Yellow
ROAD WIDENING AREA	Blue
EXISTING (To be retained)	Blue
EXISTING (To be demolished)	Yellow

Buildingwise Floor FAR Details

Floor Name	Building Name A (BUILDING)		Total	
	Proposed Built Up Area (Sq.mt.)	Proposed FAR Area (Sq.mt.)	Total Proposed Built Up Area (Sq.mt.)	Total FAR Area (Sq.mt.)
Basement Floor	88.95	0.00	88.95	0.00
Ground Floor	88.95	88.95	88.95	88.95
First Floor	88.95	88.95	88.95	88.95
Terrace Floor	0.00	0.00	0.00	0.00
Total :	266.85	177.90	266.85	177.90

Building USE/SUBUSE Details

Building Name	Building Use	Building SubUse	Building Structure
A (BUILDING)	Residential	Bungalow/ Dwelling / Non Apartment	Non-Highrise

FAR & Tenement Details (Table 4c-1)

Building	No. of Same Bldg	Total Built Up Area (Sq.mt.)	Deductions (Area in Sq.mt.)	Proposed FAR Area (Sq.mt.)	Total FAR Area (Sq.mt.)	Total Consumed Additional FAR Area (Sq.mt.)	Tnmt (No.)
A (BUILDING)	1	266.85	74.55	177.90	177.90	177.90	01
Grand Total :	1	266.85	74.55	177.90	177.90	177.90	01

LTP NAME AND SIGNATURE	STRUCTURAL ENG'S NAME AND SIGNATURE	BUILDER NAME AND SIGNATURE	DIGITAL SIGNATURE
PANKAJ KUMAR SINGH MNNP/ENG/0006/2019			