

Building :A (BUILDING)

Floor Name	Total Built Up Area (Sq.mt.)	Proposed FAR Area (Sq.mt.)	Total FAR Area (Sq.mt.)	Total Consumed Additional FAR Area (Sq.mt.)	Tnmt (No.)
Ground Floor	72.54	72.54	72.54	72.54	01
Terrace Floor	0.00	0.00	0.00	0.00	00
Total :	72.54	72.54	72.54	72.54	01
Total Number of Same Buildings	1				
Total :	72.54	72.54	72.54	72.54	01

SCHEDULE OF DOOR:

BUILDING NAME	NAME	LENGTH	HEIGHT	NOS
A (BUILDING)	D2	0.75	2.10	01
A (BUILDING)	D	0.90	2.10	03
A (BUILDING)	D1	0.90	2.10	01

SCHEDULE OF WINDOW/VENTILATION:

BUILDING NAME	NAME	LENGTH	HEIGHT	NOS
A (BUILDING)	V	0.90	0.60	01
A (BUILDING)	W	1.20	1.20	07

UnitBUA Table for Building :A (BUILDING)

FLOOR	Name	UnitBUA Type	UnitBUA Area	Carpet Area	No. of Rooms	No. of Tenement
GROUND FLOOR PLAN	SPLIT A	FLAT	63.26	62.86	5	1
Total:	-	-	63.26	62.86	5	1

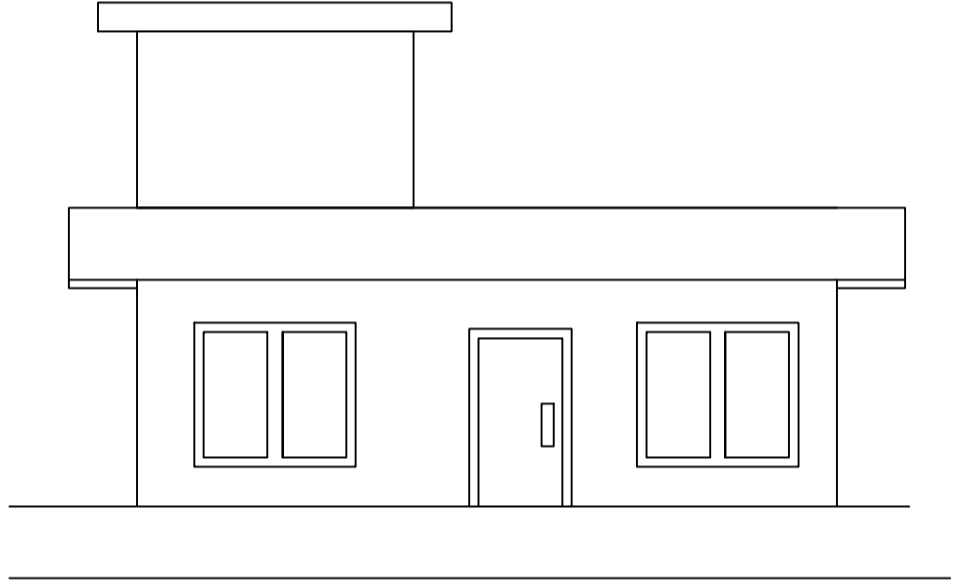
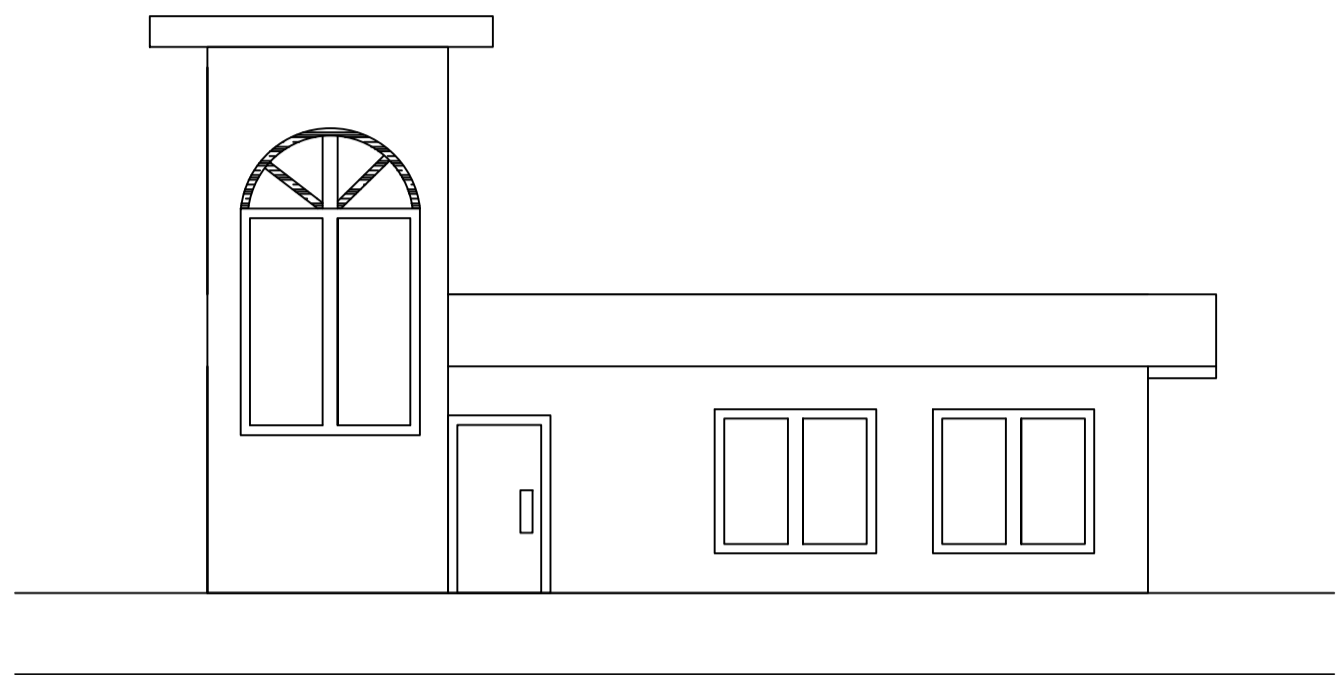
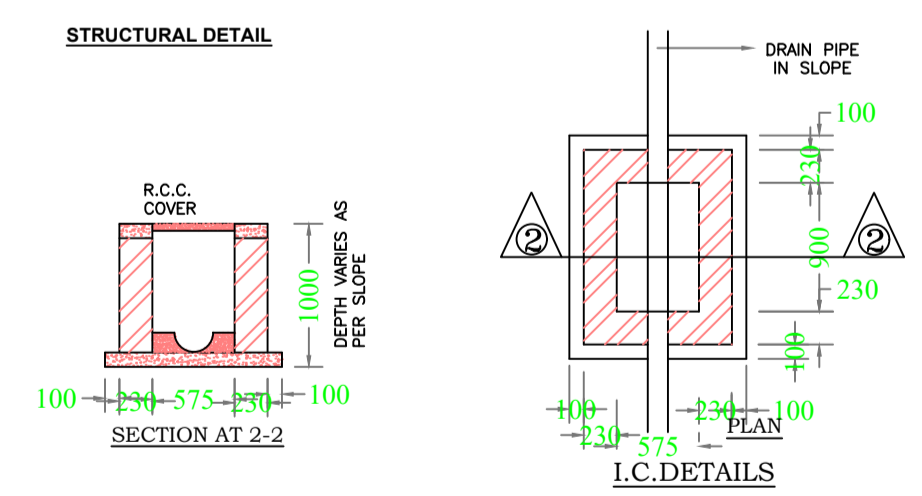
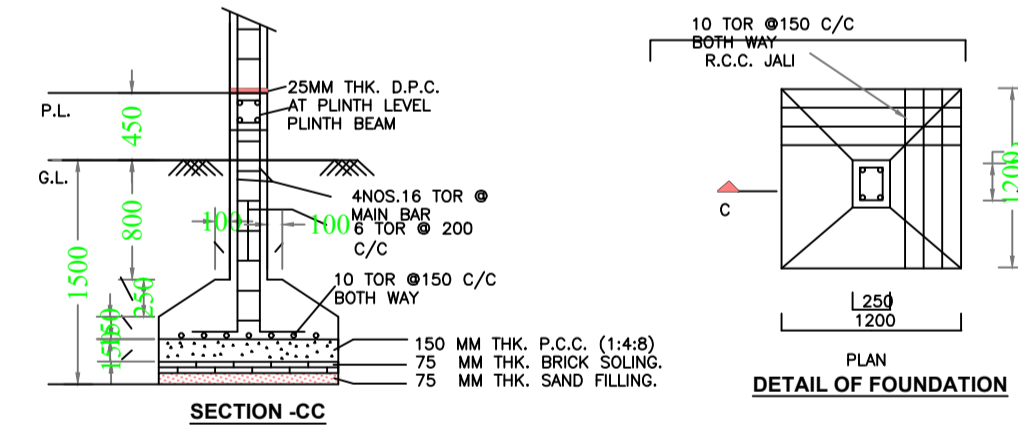
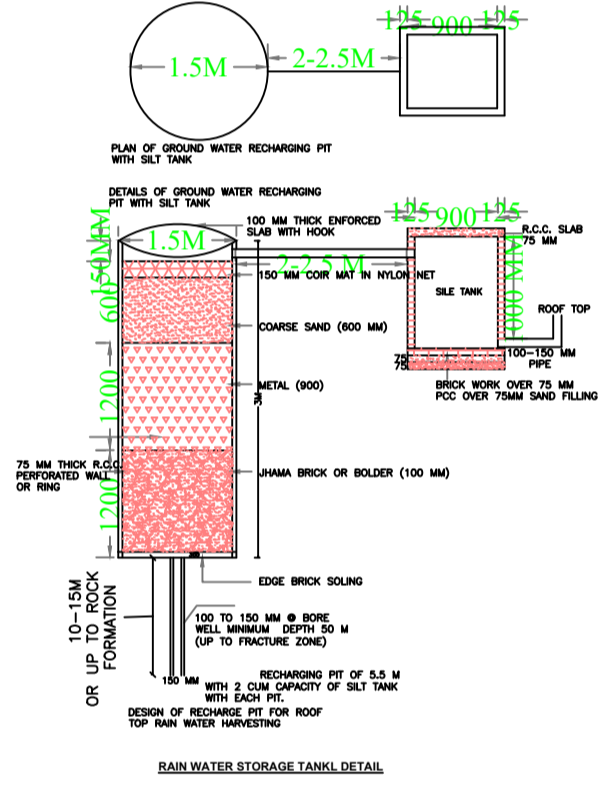
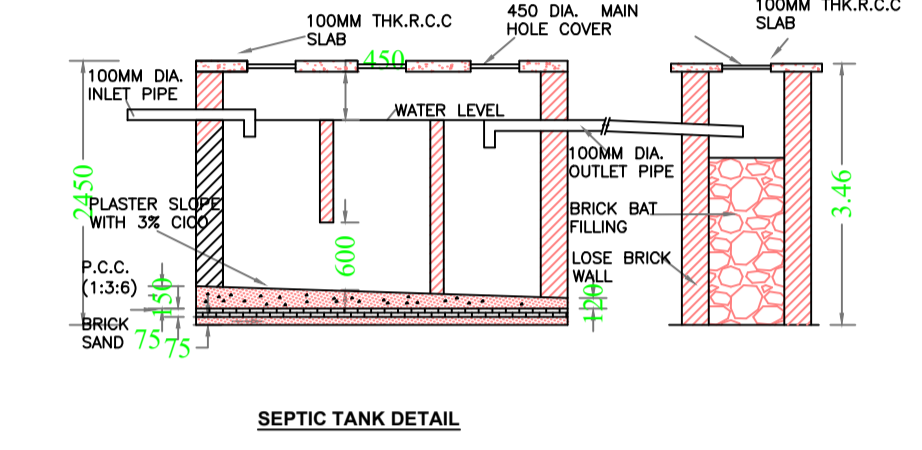
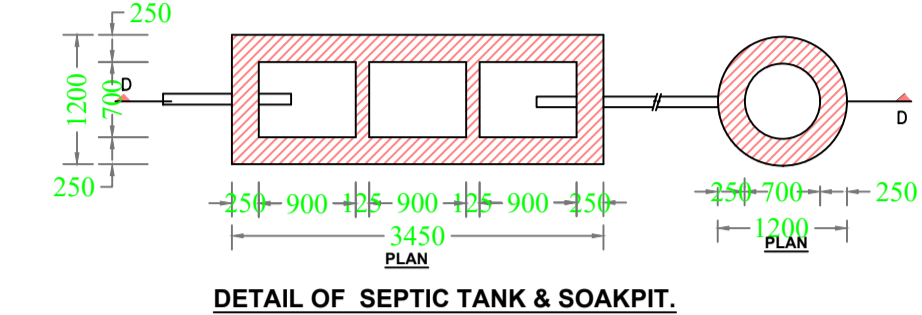

FAR & Tenement Details (Table 4c-1)

Building	No. of Same Bldg	Total Built Up Area (Sq.mt.)	Proposed FAR Area (Sq.mt.)	Total FAR Area (Sq.mt.)	Total Consumed Additional FAR Area (Sq.mt.)	Tnmt (No.)
A (BUILDING)	1	72.54	72.54	72.54	72.54	01
Grand Total :	1	72.54	72.54	72.54	72.54	01

Proposal Basic Information

Proposal File No.	MNNP/BP/0058/W04/2023
Owner Name	Nitu Devi
Khata No	101
Plot No	146
Village Name	Baralota
Use	Residential
SubUse	Bungalow/ Dwelling / Non Apartment

AREA STATEMENT MEDININAGAR MUNICIPAL CORPORATION

PROJECT DETAIL:

Region: JHARKHAND URBAN LOCAL BODIES	Plot Use: Residential
District: PALAMU	Plot SubUse: Bungalow/ Dwelling / Non Apartment
Authority: MEDININAGAR MUNICIPAL CORPORATION	PlotNearbyReligiousStructure: NA
Inward No: MNNP/BP/0058/W04/2023	Plot/SubPlot No: 146
Application Type: General Proposal	North: -
Project Type: Building Permission	South: -
Nature of Development: New	East: -
Location of Development Area: Old Area	West: -

AREA DETAILS:

AREA OF PLOT (Minimum)	(A)	SQ.MT.
AREA OF PLOT (Minimum)	(A)	121.44
Deduction for NetPlot Area		
Surrender Free of Cost		7.01
Total		7.01
NET AREA OF PLOT(Gross Plot Area - Deduction from Gross Plot area)	(A-Deductions)	114.43
Deduction for Balance Plot Area(from Gross Plot Area)		
Surrender Free of Cost		7.01
Common Plot		19.40
Total		26.41
BALANCE AREA OF PLOT(Net Plot Area - Recreational/Amenity space)	(A-Deductions)	95.03
PLOT AREA FOR COVERAGE(Net Plot Area)	(A-Deductions)	114.43
Plot Area for FAR (Net Plot Area + RoadWidening Area)	(A-Deductions)	121.44

COVERAGE CHECK

Permissible Coverage area (70.00 %)	80.10
Proposed Coverage Area (63.39 %)	72.54
Total Prop. Coverage Area (63.39 %)	72.54
Balance coverage area (6.61 %)	7.56

FAR CHECK

Perm. FAR Area (1.500)	182.16
Total Perm. FAR area	182.16
Residential FAR	72.54
Proposed FAR Area	72.54
Total Proposed FAR Area	72.54
Consumed FAR (Factor)	0.60
Balance FAR Area	109.62

BUILT UP AREA CHECK

Total Proposed BuiltUp Area	72.54
-----------------------------	-------

ARCHITECT (Regd) RANJIT KUMAR
ENGINEER (Regd)
SUPERVISOR (Regd)
OWNER (Regd) Nitu Devi

DEVELOPMENT AUTHORITY LOCAL BODY

COLOR INDEX

PLOT BOUNDARY	
ABUTTING ROAD	
PROPOSED CONSTRUCTION	
COMMON PLOT	
ROAD WIDENING AREA	
EXISTING (To be retained)	
EXISTING (To be demolished)	

Buildingwise Floor FAR Details

Floor Name	Building Name A (BUILDING)		Total	
	Proposed Built Up Area (Sq.mt.)	Proposed FAR Area (Sq.mt.)	Total Proposed Built Up Area (Sq.mt.)	Total FAR Area (Sq.mt.)
Ground Floor	72.54	72.54	72.54	72.54
Terrace Floor	0.00	0.00	0.00	0.00
Total :	72.54	72.54	72.54	72.54

Building USE/SUBUSE Details

Building Name	Building Use	Building SubUse	Building Structure
A (BUILDING)	Residential	Bungalow/ Dwelling / Non Apartment	Non-Highrise

LTP NAME AND SIGNATURE	STRUCTURAL ENG'S NAME AND SIGNATURE	BUILDER NAME AND SIGNATURE	DIGITAL SIGNATURE
RANJIT KUMAR MNNP/ENG/0001/2016			