

SITE PLAN

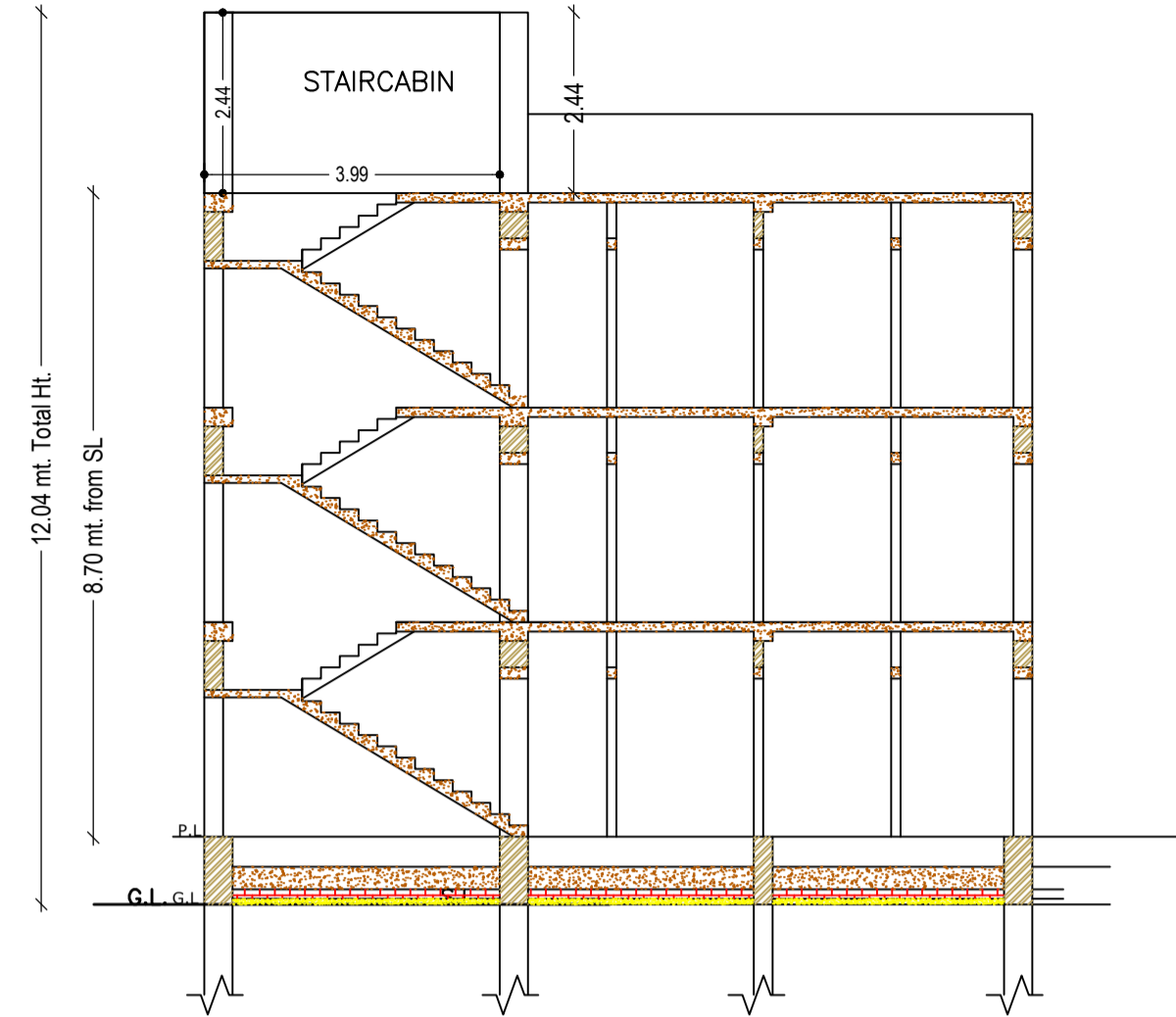

CROSS SECTION (A)

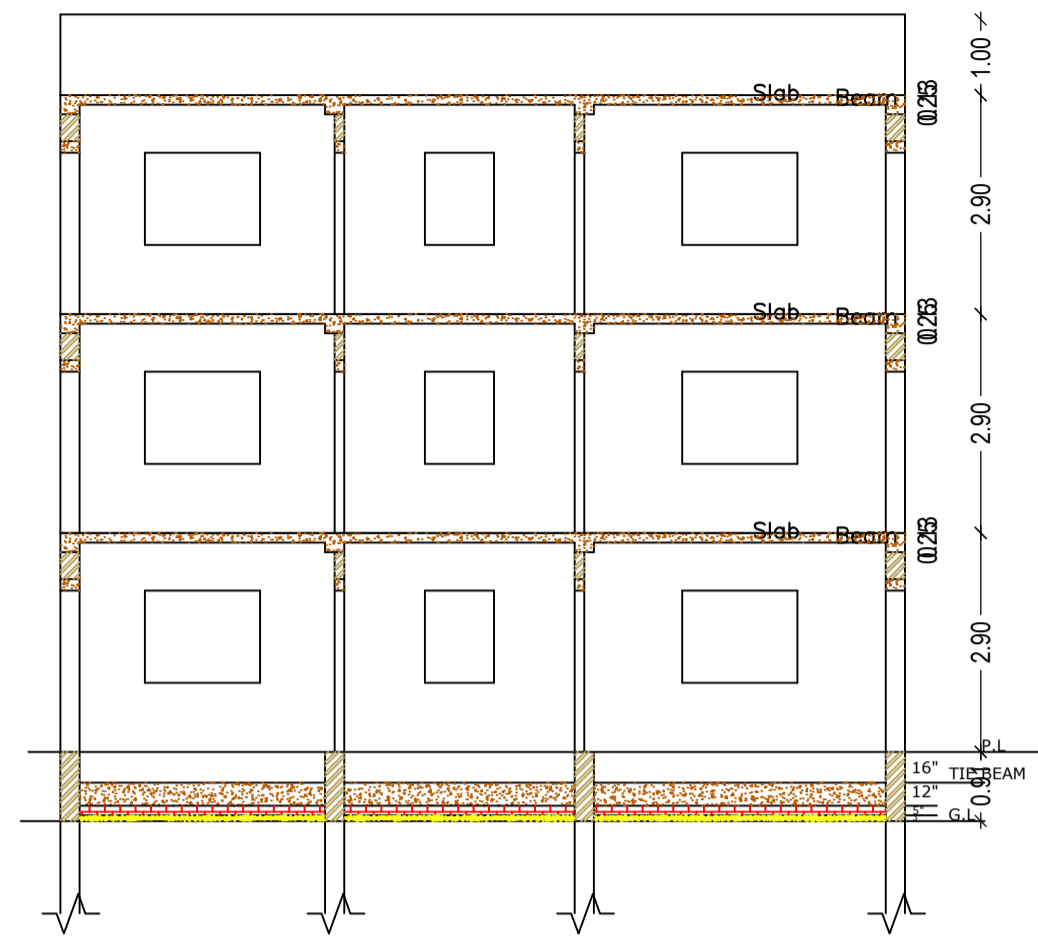

CROSS SECTION (B)

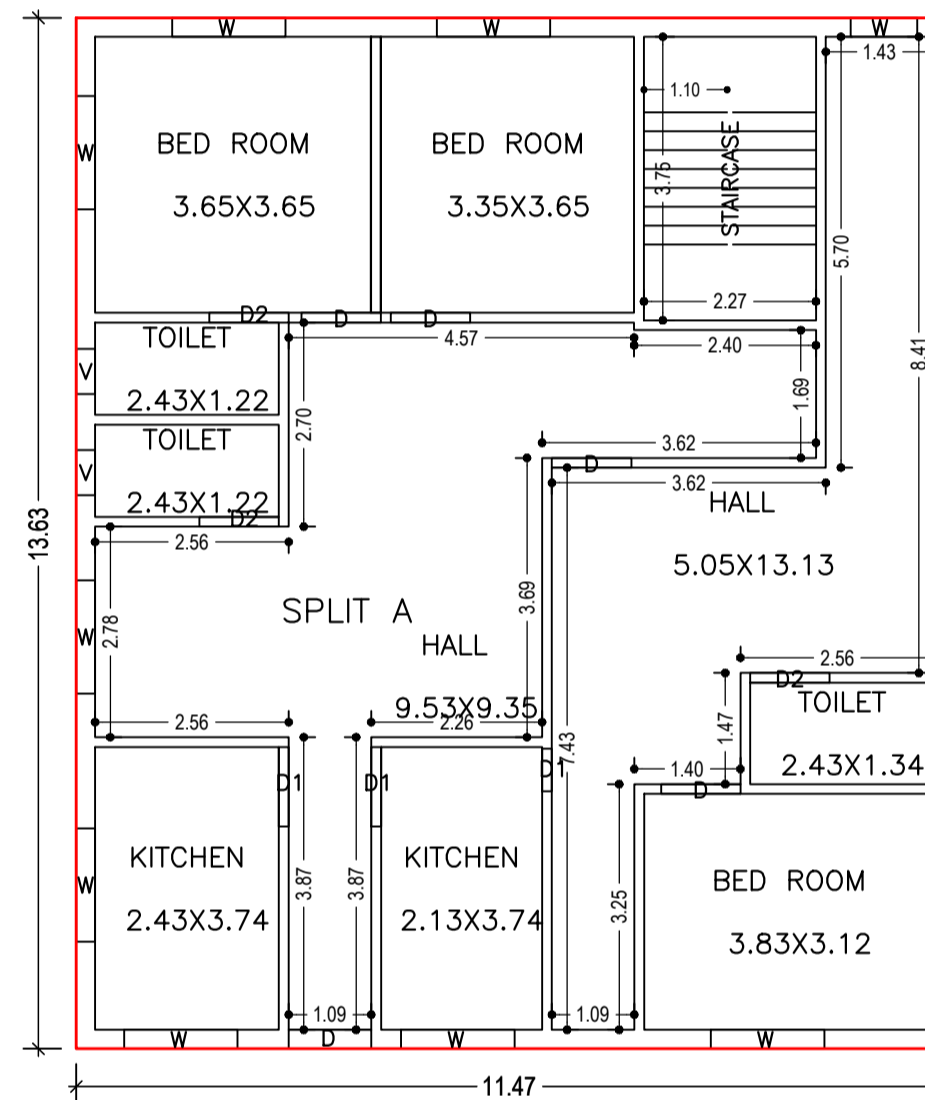

SECOND FLOOR PLAN (Proposed) (SCALE 1:100)

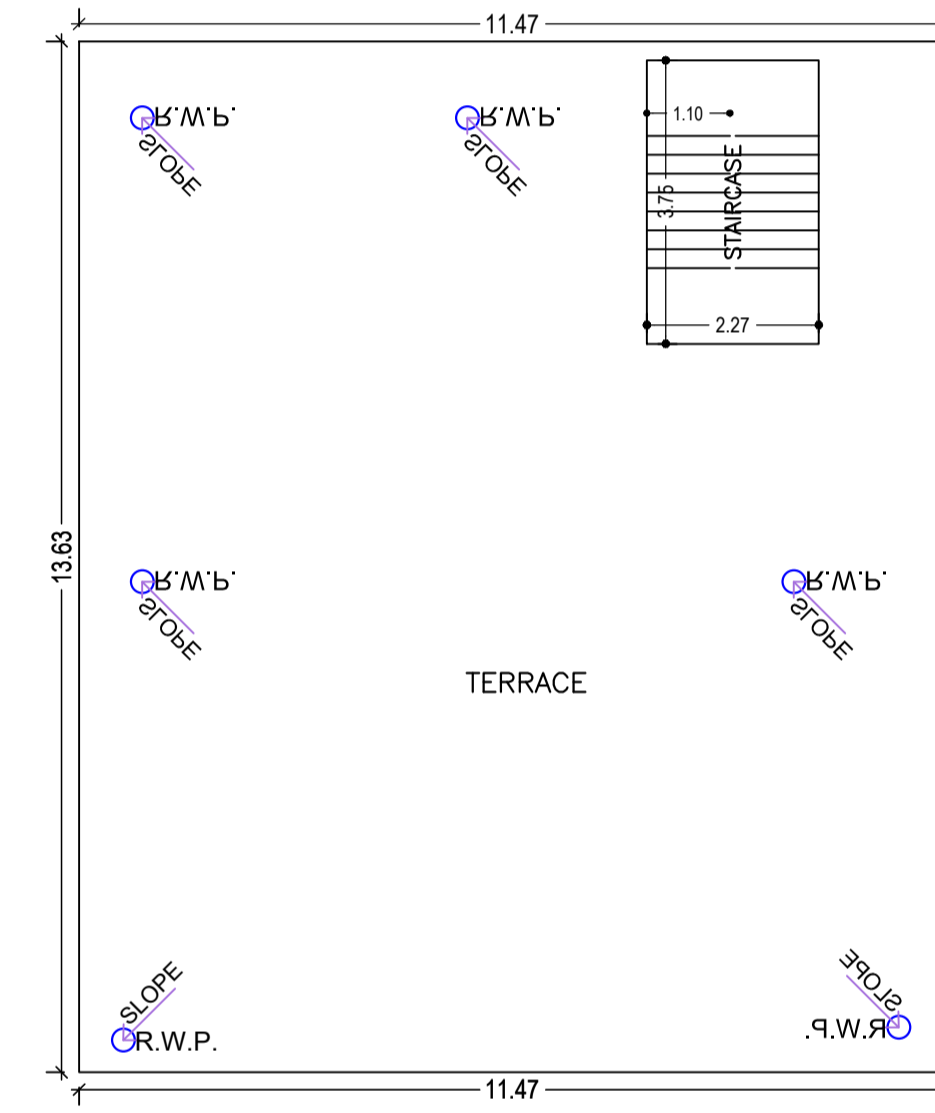

TERRACE FLOOR PLAN (SCALE 1:100)

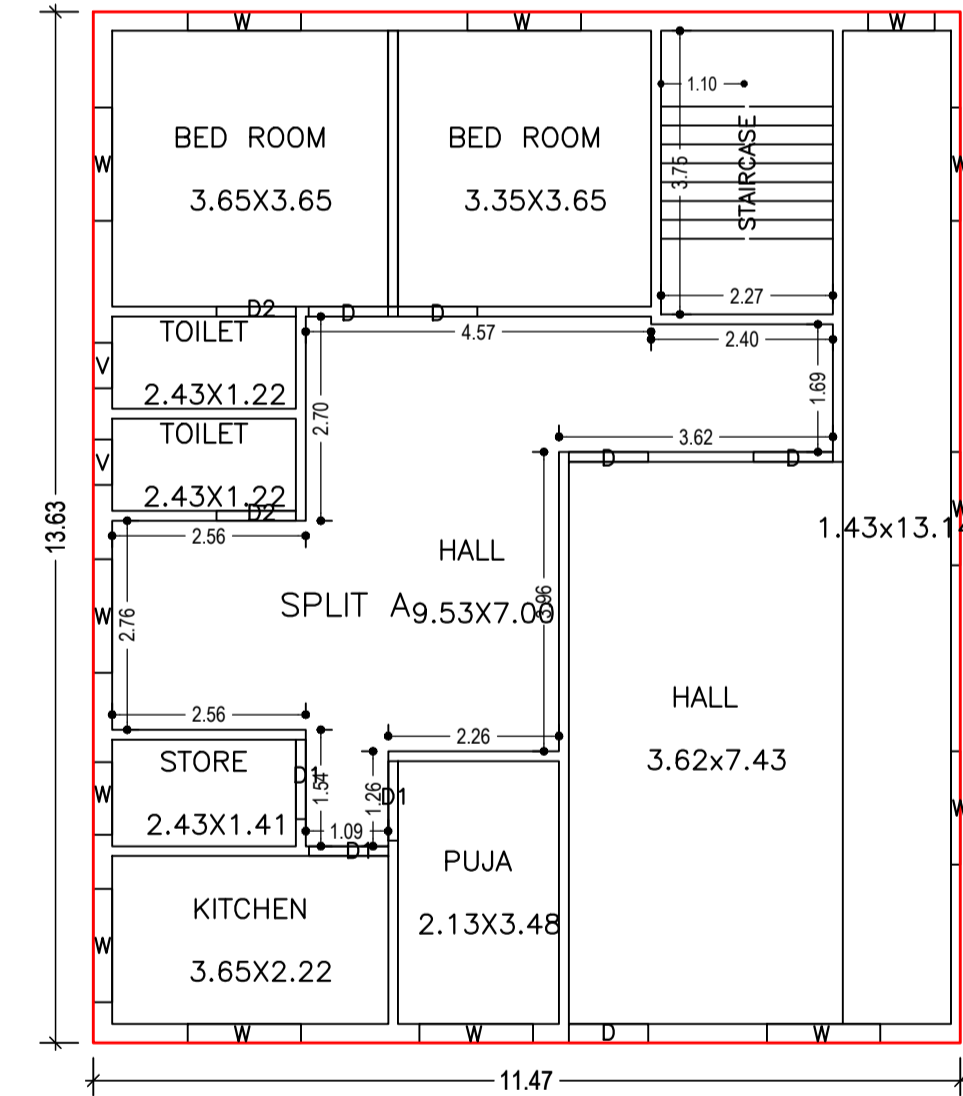

GROUND FLOOR PLAN (Proposed) (SCALE 1:100)

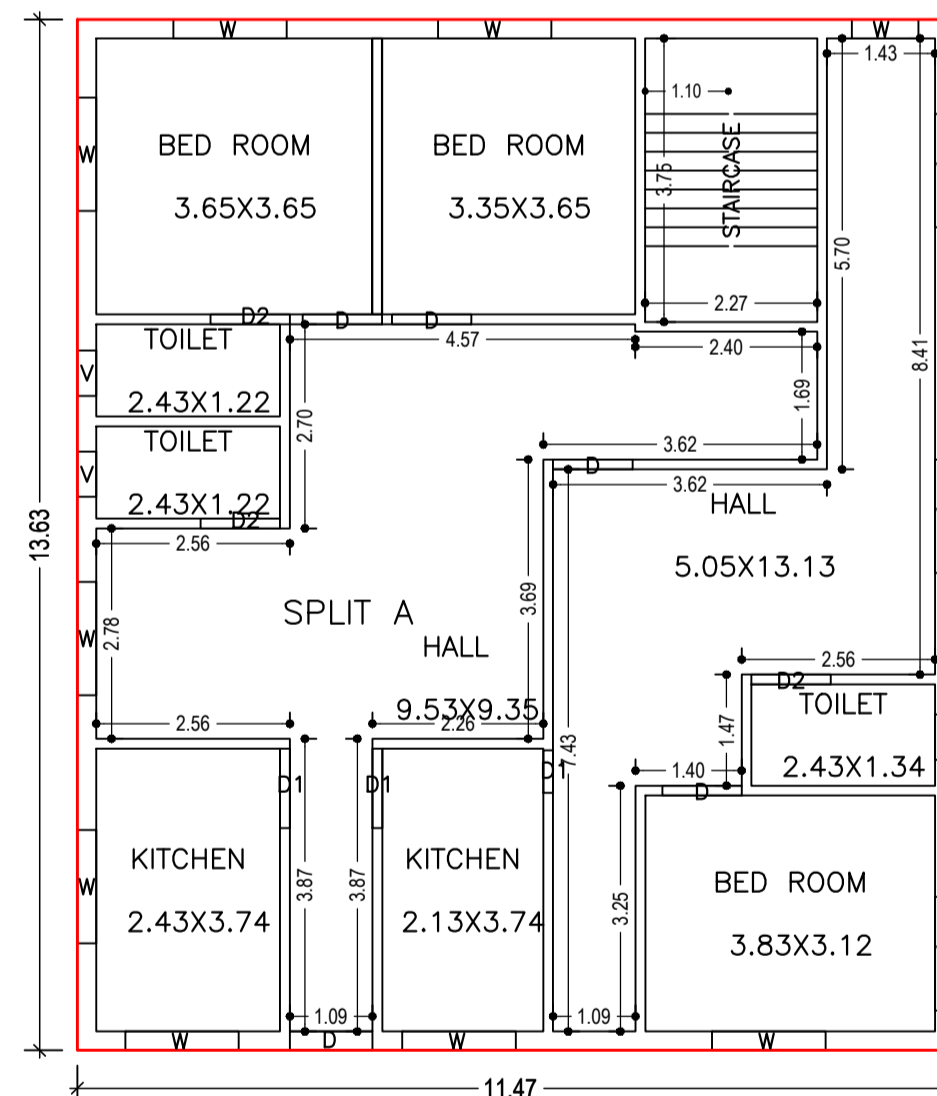

FIRST FLOOR PLAN (Proposed) (SCALE 1:100)

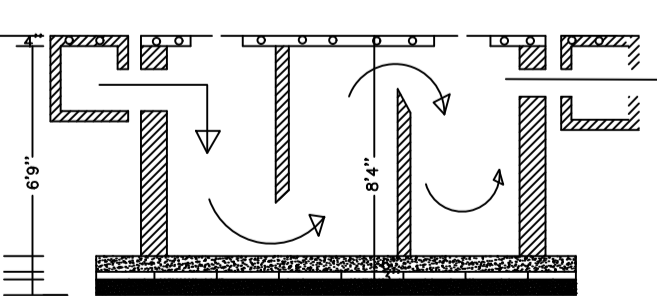

SECTION

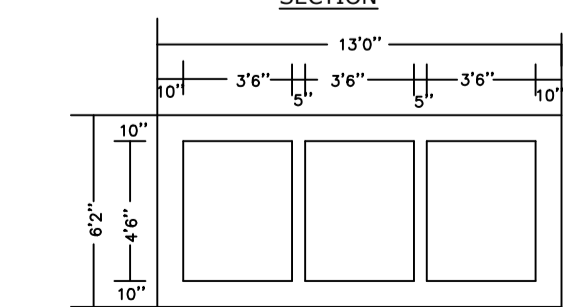

PLAN OF SEPTIC TANK

| Floor Name | Total Built Up Area (Sq.mt.) | Proposed FAR Area (Sq.mt.) | Total FAR Area (Sq.mt.) | Total Consumed Additional FAR Area (Sq.mt.) | Tnmt (No.) |
|----------------------------------|------------------------------|----------------------------|-------------------------|---|------------|
| Ground Floor | 156.40 | 156.40 | 156.40 | 156.40 | 01 |
| First Floor | 156.40 | 156.40 | 156.40 | 156.40 | 00 |
| Second Floor | 156.40 | 156.40 | 156.40 | 156.40 | 00 |
| Terrace Floor | 0.00 | 0.00 | 0.00 | 0.00 | 00 |
| Total : | 469.20 | 469.20 | 469.20 | 469.20 | 01 |
| Total Number of Same Buildings : | 1 | | | | |
| Total : | 469.20 | 469.20 | 469.20 | 469.20 | 01 |

UnitBUA Table for Building :A (RESIDENTIAL)

| FLOOR | Name | UnitBUA Type | UnitBUA Area | Carpet Area | No. of Rooms | No. of Tenement |
|-------------------|---------|--------------|--------------|-------------|--------------|-----------------|
| GROUND FLOOR PLAN | SPLIT A | FLAT | 441.90 | 440.47 | 9 | 1 |
| FIRST FLOOR PLAN | SPLIT A | FLAT | 0.00 | 0.00 | 10 | 0 |
| SECOND FLOOR PLAN | SPLIT A | FLAT | 0.00 | 0.00 | 10 | 0 |
| Total : | - | - | 441.90 | 440.47 | 29 | 1 |

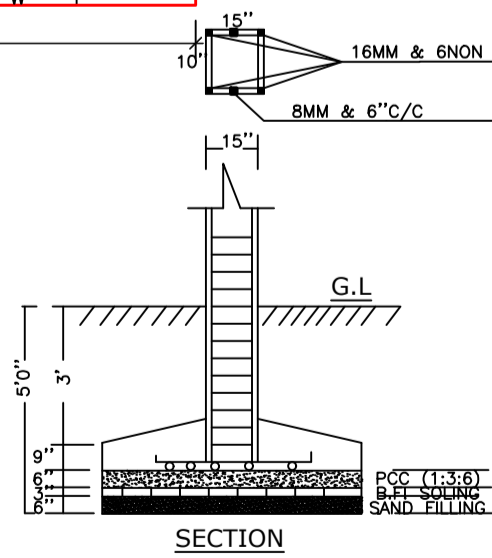

SECTION

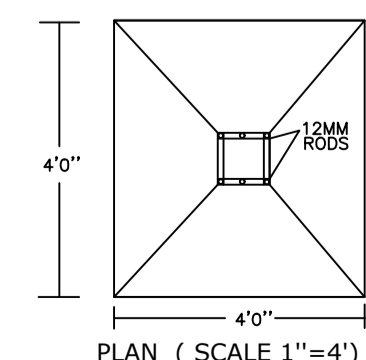

PLAN (SCALE 1"=4')

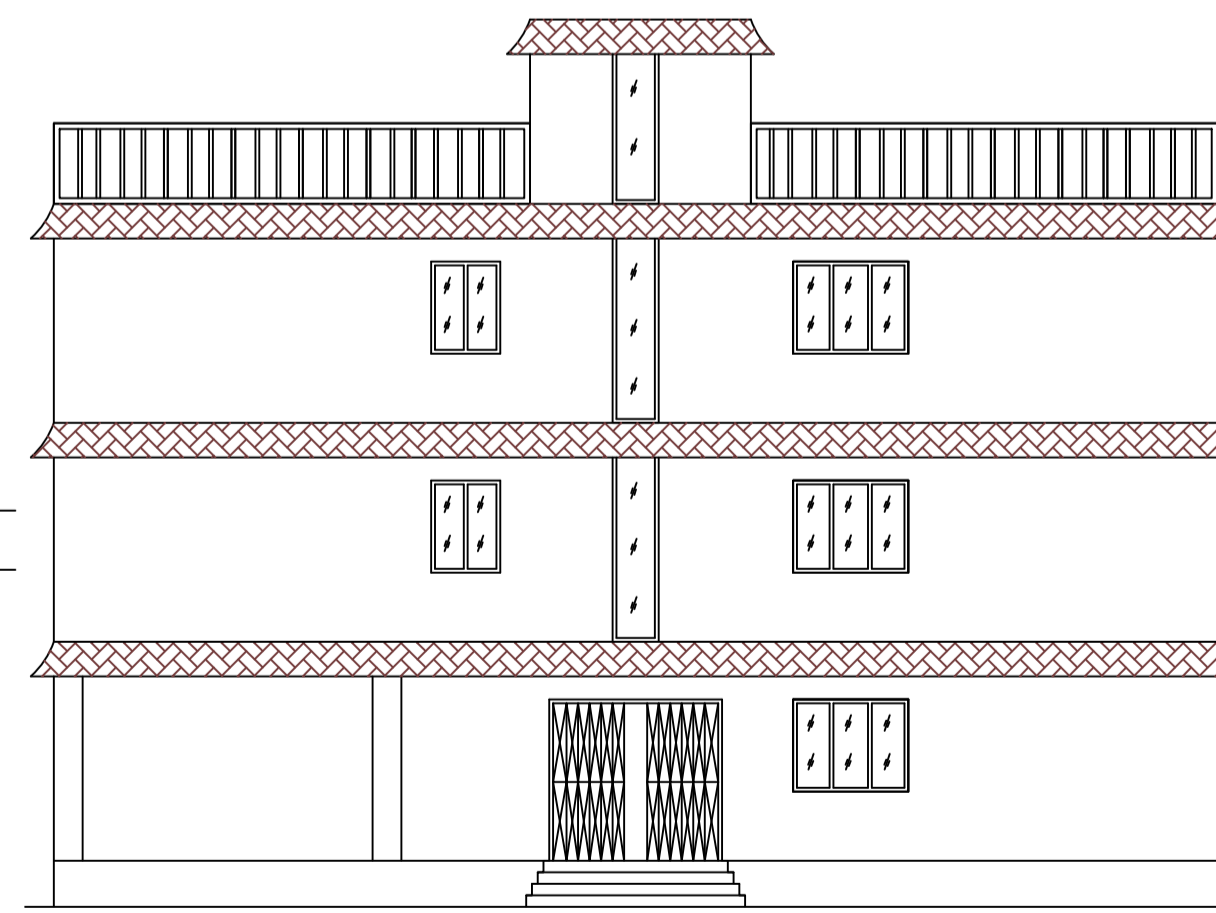

CROSS ELEVATION

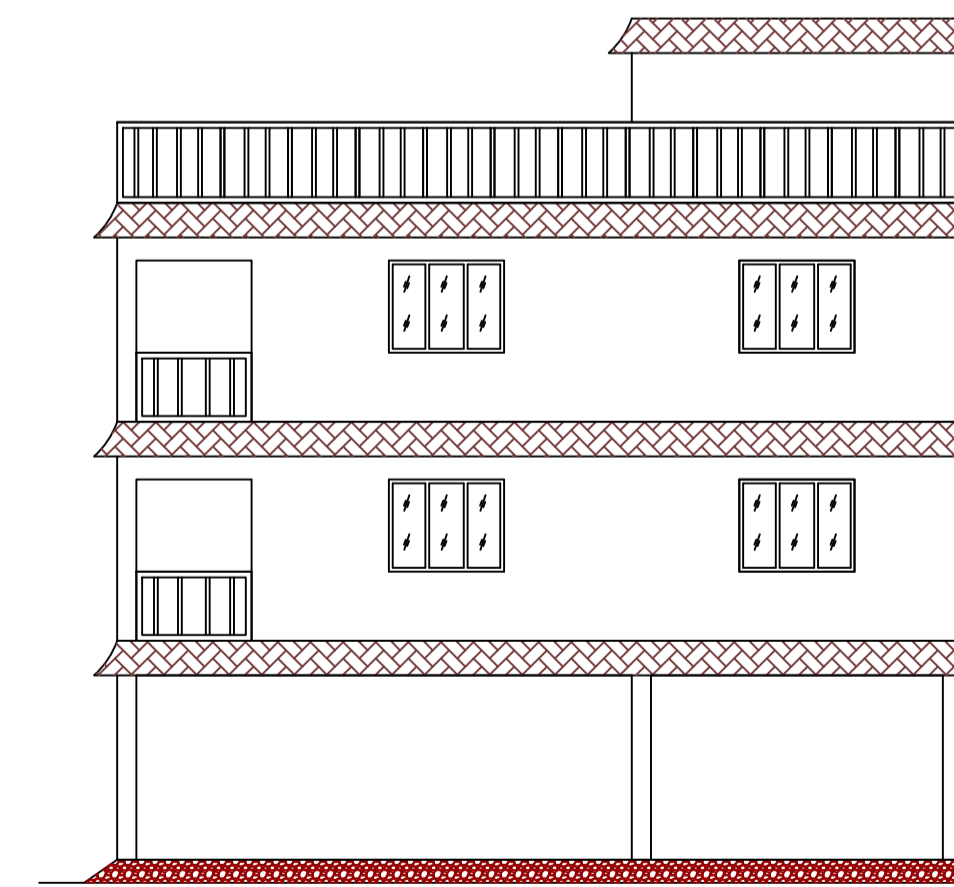

FRONT ELEVATION

FAR & Tenement Details (Table 4c-1)

| Building | No. of Same Bldg | Total Built Up Area (Sq.mt.) | Proposed FAR Area (Sq.mt.) | Total FAR Area (Sq.mt.) | Total Consumed Additional FAR Area (Sq.mt.) | Tnmt (No.) |
|-----------------|------------------|------------------------------|----------------------------|-------------------------|---|------------|
| A (RESIDENTIAL) | 1 | 469.20 | 469.20 | 469.20 | 469.20 | 01 |
| Grand Total | 1 | 469.20 | 469.20 | 469.20 | 469.20 | 01 |

SCHEDULE OF DOOR:

| BUILDING NAME | NAME | LENGTH | HEIGHT | NOS |
|-----------------|------|--------|--------|-----|
| A (RESIDENTIAL) | D1 | 0.56 | 2.10 | 02 |
| A (RESIDENTIAL) | D | 1.05 | 2.10 | 13 |
| A (RESIDENTIAL) | D2 | 1.05 | 2.10 | 08 |
| A (RESIDENTIAL) | D1 | 1.05 | 2.10 | 07 |
| A (RESIDENTIAL) | D | 1.09 | 2.10 | 02 |

SCHEDULE OF WINDOW/VENTILATION:

| BUILDING NAME | NAME | LENGTH | HEIGHT | NOS |
|-----------------|------|--------|--------|-----|
| A (RESIDENTIAL) | V | 0.60 | 0.90 | 08 |
| A (RESIDENTIAL) | W | 0.88 | 1.20 | 03 |
| A (RESIDENTIAL) | W | 0.96 | 1.20 | 01 |
| A (RESIDENTIAL) | W | 1.50 | 1.20 | 33 |

Proposal Basic Information

| | |
|-------------------|------------------------------------|
| Proposal File No. | MNNP/BI/0057/W08/2023 |
| Owner Name | BASANT KUMAR GUPTA |
| Khata No. | 49 |
| Plot No. | 1441 |
| Village Name | Sudna |
| Use | Residential |
| SubUse | Bungalow/ Dwelling / Non Apartment |

| AREA STATEMENT | | VERSION NO. : 1.0.66 |
|--|---|--------------------------|
| MEDININAGAR MUNICIPAL CORPORATION | | VERSION DATE: 16/10/2020 |
| PROJECT DETAIL: | | |
| Region: JHARKHAND URBAN LOCAL BODIES | Plot Use: Residential | |
| District: PALAMU | Plot SubUse: Bungalow/ Dwelling / Non Apartment | |
| Authority: MEDININAGAR MUNICIPAL CORPORATION | PlotNearbyReligiousStructure: NA | |
| Inward No: MNNP/BI/0057/W08/2023 | Plot/SubPlot No: 1441 | |
| Application Type: General Proposal | North: - | |
| Project Type: Building Permission | South: - | |
| Nature of Development: New | East: - | |
| Location of Development Area: Old Area | West: - | |
| AREA DETAILS: | | SQ.MT. |
| AREA OF PLOT (Minimum) | (A) | 272.70 |
| Deduction for NetPlot Area | | |
| Surrender Free of Cost | | 10.77 |
| Total | | 10.77 |
| NET AREA OF PLOT(Gross Plot Area - Deduction from Gross Plot area) | (A-Deductions) | 261.93 |
| Deduction for Balance Plot Area(from Gross Plot Area) | | |
| Surrender Free of Cost | | 10.77 |
| Common Plot | | 44.29 |
| Total | | 55.06 |
| BALANCE AREA OF PLOT(Net Plot Area - Recreational/Amenity space) | (A-Deductions) | 217.64 |
| PLOT AREA FOR COVERAGE(Net Plot Area - Road/Widening Area) | (A-Deductions) | 261.93 |
| Plot Area for FAR (Net Plot Area - Road/Widening Area) | (A-Deductions) | 272.70 |
| COVERAGE CHECK | | |
| Permissible Coverage area (60.00 %) | | 157.16 |
| Proposed Coverage Area (59.71 %) | | 156.40 |
| Total Prop. Coverage Area (59.71 %) | | 156.40 |
| Balance coverage area (0.29 %) | | 0.76 |
| FAR CHECK | | |
| Perm. FAR Area (2.500) | | 681.75 |
| Total Perm. FAR area | | 681.75 |
| Residential FAR | | 469.20 |
| Proposed FAR Area | | 469.20 |
| Total Proposed FAR Area | | 469.20 |
| Consumed FAR (Factor) | | 1.72 |
| Balance FAR Area | | 212.55 |
| BUILT UP AREA CHECK | | |
| Total Proposed BuiltUp Area | | 469.20 |
| ARCHITECT (Regd) | | RANJIT KUMAR |
| ENGINEER (Regd) | | |
| SUPERVISOR (Regd) | | |
| OWNER (Regd) | | BASANT KUMAR GUPTA |
| DEVELOPMENT AUTHORITY | | LOCAL BODY |

COLOR INDEX

| | |
|-----------------------------|--------|
| PLOT BOUNDARY | Black |
| ABUTTING ROAD | Red |
| PROPOSED CONSTRUCTION | Green |
| COMMON PLOT | Yellow |
| ROAD WIDENING AREA | Blue |
| EXISTING (To be retained) | Orange |
| EXISTING (To be demolished) | Pink |

Buildingwise Floor FAR Details

| Floor Name | Building Name A (RESIDENTIAL) | | Total | |
|---------------|---------------------------------|----------------------------|---------------------------------------|-------------------------|
| | Proposed Built Up Area (Sq.mt.) | Proposed FAR Area (Sq.mt.) | Total Proposed Built Up Area (Sq.mt.) | Total FAR Area (Sq.mt.) |
| Ground Floor | 156.40 | 156.40 | 156.40 | 156.40 |
| First Floor | 156.40 | 156.40 | 156.40 | 156.40 |
| Second Floor | 156.40 | 156.40 | 156.40 | 156.40 |
| Terrace Floor | 0.00 | 0.00 | 0.00 | 0.00 |
| Total : | 469.20 | 469.20 | 469.20 | 469.20 |

Building USE/SUBUSE Details

| Building Name | Building Use | Building SubUse | Building Structure |
|-----------------|--------------|------------------------------------|--------------------|
| A (RESIDENTIAL) | Residential | Bungalow/ Dwelling / Non Apartment | Non-Highrise |

| LTP NAME AND SIGNATURE | STRUCTURAL ENG'S NAME AND SIGNATURE | BUILDER NAME AND SIGNATURE | DIGITAL SIGNATURE |
|------------------------------------|-------------------------------------|----------------------------|-------------------|
| RANJIT KUMAR MNNP/ENG/0001/2016 | | | |