

SITE PLAN

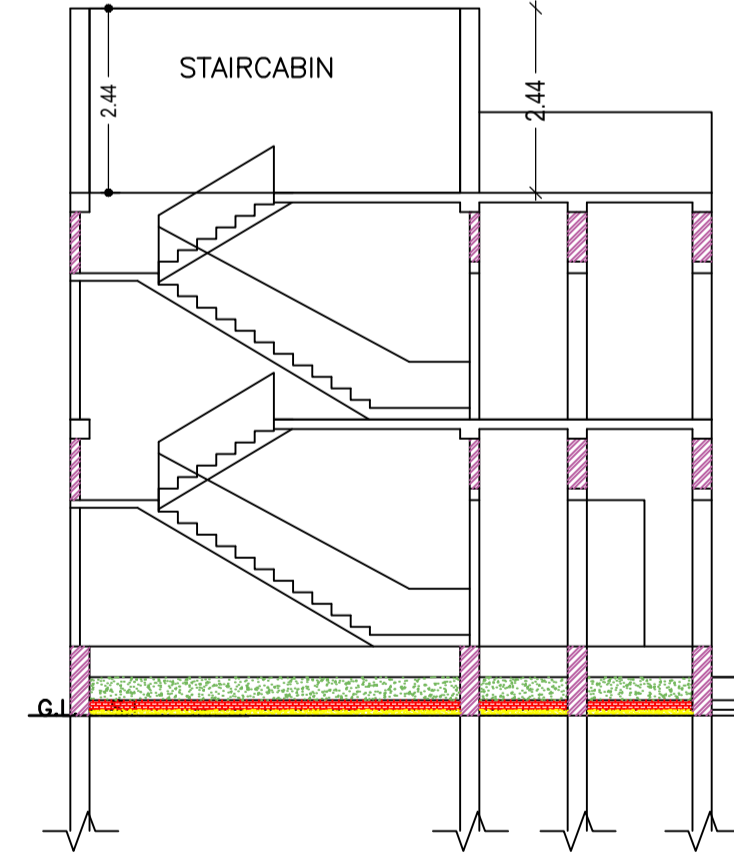

CROSS SECTION (A)

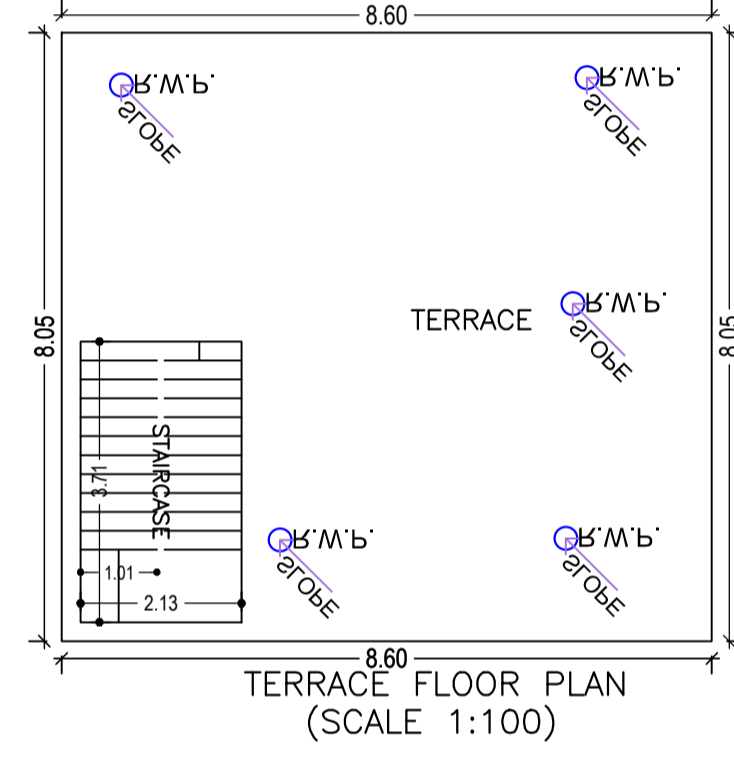
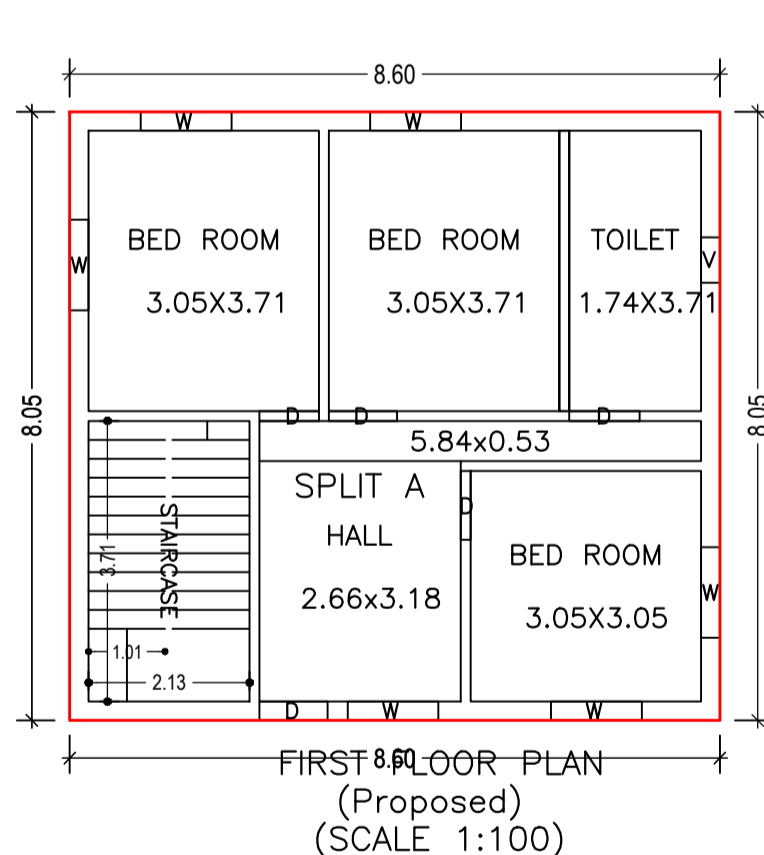
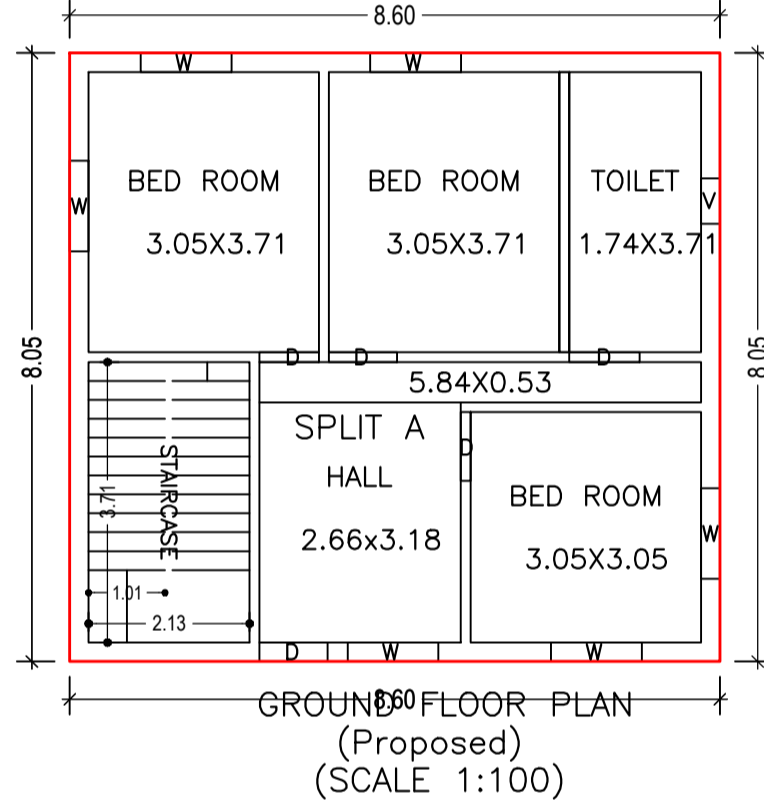
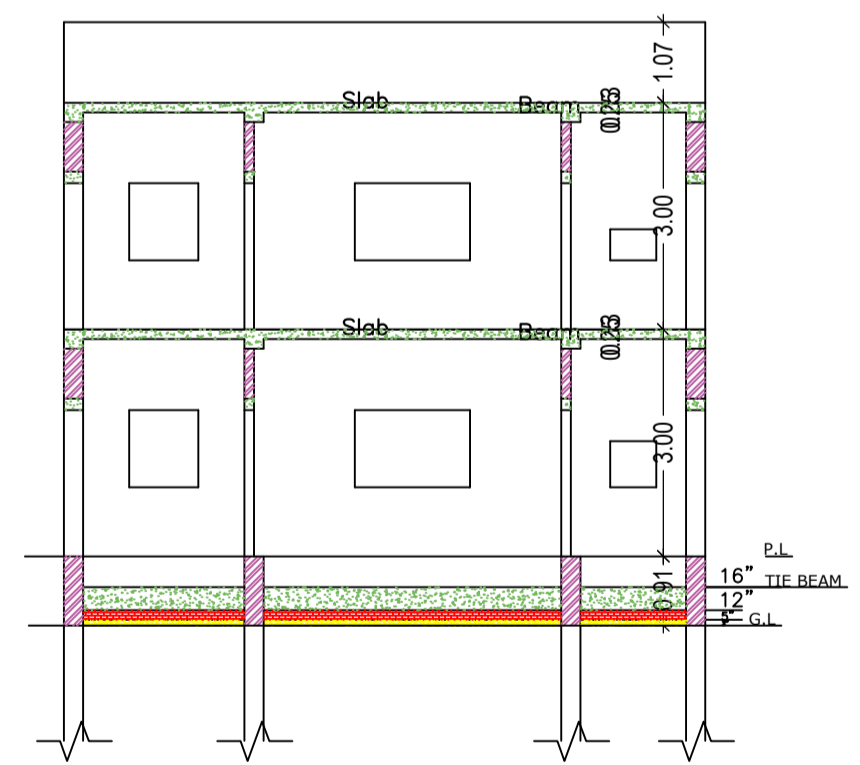

CROSS SECTION (B)

Building :A (RESIDENTIAL)

Floor Name	Total Built Up Area (Sq.mt.)	Proposed FAR Area (Sq.mt.) Resi.	Total FAR Area (Sq.mt.)	Total Consumed Additional FAR Area (Sq.mt.)	Tnmt (No.)
Ground Floor	69.21	69.21	69.21	69.21	01
First Floor	69.21	69.21	69.21	69.21	00
Terrace Floor	0.00	0.00	0.00	0.00	00
Total :	138.42	138.42	138.42	138.42	01
Total Number of Same Buildings	1				
Total :	138.42	138.42	138.42	138.42	01

SCHEDULE OF DOOR:

BUILDING NAME	NAME	LENGTH	HEIGHT	NOS
A (RESIDENTIAL)	D	0.79	2.10	02
A (RESIDENTIAL)	D	0.90	2.10	04
A (RESIDENTIAL)	D	0.91	2.10	02
A (RESIDENTIAL)	D	0.93	2.10	02

SCHEDULE OF WINDOW/VENTILATION:

BUILDING NAME	NAME	LENGTH	HEIGHT	NOS
A (RESIDENTIAL)	V	0.60	0.90	02
A (RESIDENTIAL)	W	1.20	1.20	12

UnitBUA Table for Building :A (RESIDENTIAL)

FLOOR	Name	UnitBUA Type	UnitBUA Area	Carpet Area	No. of Rooms	No. of Tenement
FIRST FLOOR PLAN	SPLIT A	FLAT	0.00	0.00	5	0
GROUND FLOOR PLAN	SPLIT A	FLAT	119.57	118.61	5	1
Total:	-	-	119.57	118.61	10	1

FAR & Tenement Details (Table 4c-1)

Building	No. of Same Bldg	Total Built Up Area (Sq.mt.)	Proposed FAR Area (Sq.mt.) Resi.	Total FAR Area (Sq.mt.)	Total Consumed Additional FAR Area (Sq.mt.)	Tnmt (No.)
A (RESIDENTIAL)	1	138.42	138.42	138.42	138.42	01
Grand Total :	1	138.42	138.42	138.42	138.42	01

Proposal Basic Information

Proposal File No.	MNNP/BJP/0113/W18/2023
Owner Name	Rima Devi
Khata No	62
Plot No	1755
Village Name	Redma
Use	Residential
SubUse	Bungalow/ Dwelling / Non Apartment

AREA STATEMENT

AREA DETAILS:		SQ.MT.
AREA OF PLOT (Minimum)	(A)	121.44
Deduction for NetPlot Area		
Surrender Free of Cost		10.17
Total		10.17
NET AREA OF PLOT(Gross Plot Area - Deduction from Gross Plot area)	(A-Deductions)	111.28
Deduction for Balance Plot Area(from Gross Plot Area)		
Surrender Free of Cost		10.17
Common Plot		15.83
Total		25.99
BALANCE AREA OF PLOT(Net Plot Area - Recreational/Amenity space)	(A-Deductions)	95.45
PLOT AREA FOR COVERAGE(Net Plot Area)	(A-Deductions)	111.28
Plot Area for FAR (Net Plot Area + Road/Widening Area)	(A-Deductions)	121.44
COVERAGE CHECK		
Permissible Coverage area (70.00 %)		77.90
Proposed Coverage Area (62.20 %)		69.21
Total Prop. Coverage Area (62.2 %)		69.21
Balance coverage area (7.81 %)		8.69
FAR CHECK		
Perm. FAR Area (1.500)		182.16
Total Perm. FAR area		182.16
Residential FAR		138.42
Proposed FAR Area		138.42
Total Proposed FAR Area		138.42
Consumed FAR (Factor)		1.14
Balance FAR Area		43.74
BUILT UP AREA CHECK		
Total Proposed BuiltUp Area		138.42
ARCHITECT (Regd)	RANJIT KUMAR	
ENGINEER (Regd)		
SUPERVISOR (Regd)		
OWNER (Regd)	Rima Devi	
DEVELOPMENT AUTHORITY	LOCAL BODY	

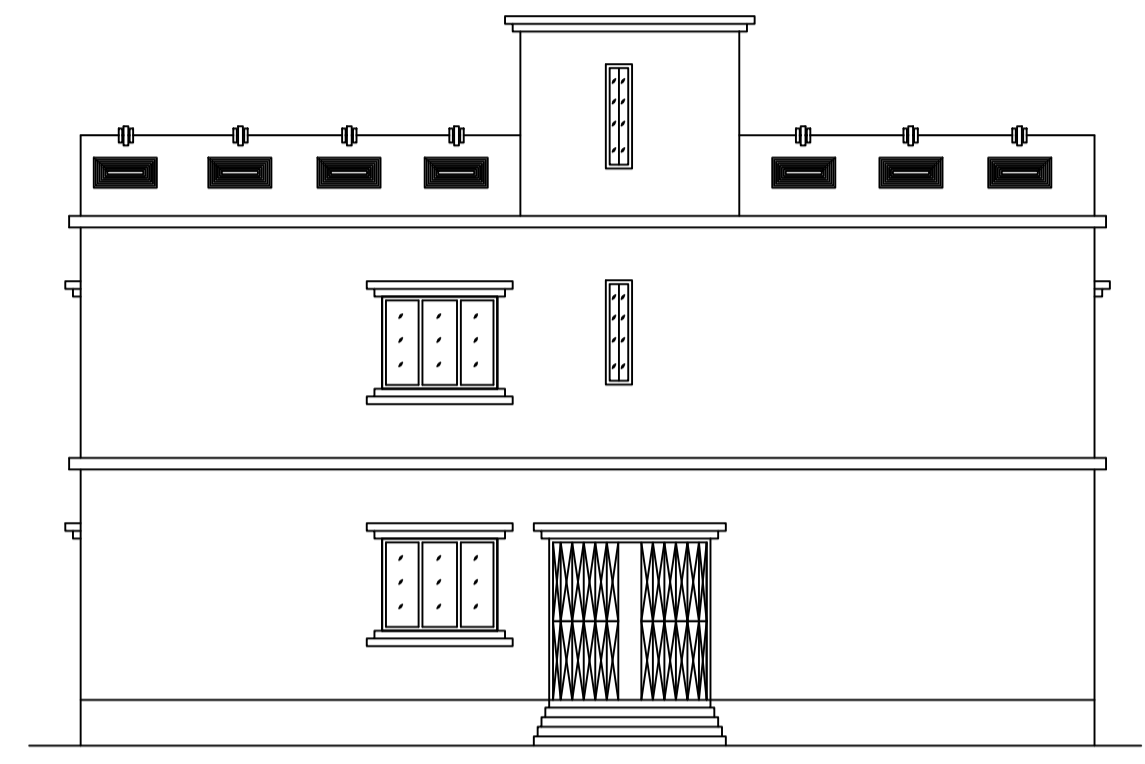

CROSS ELEVATION

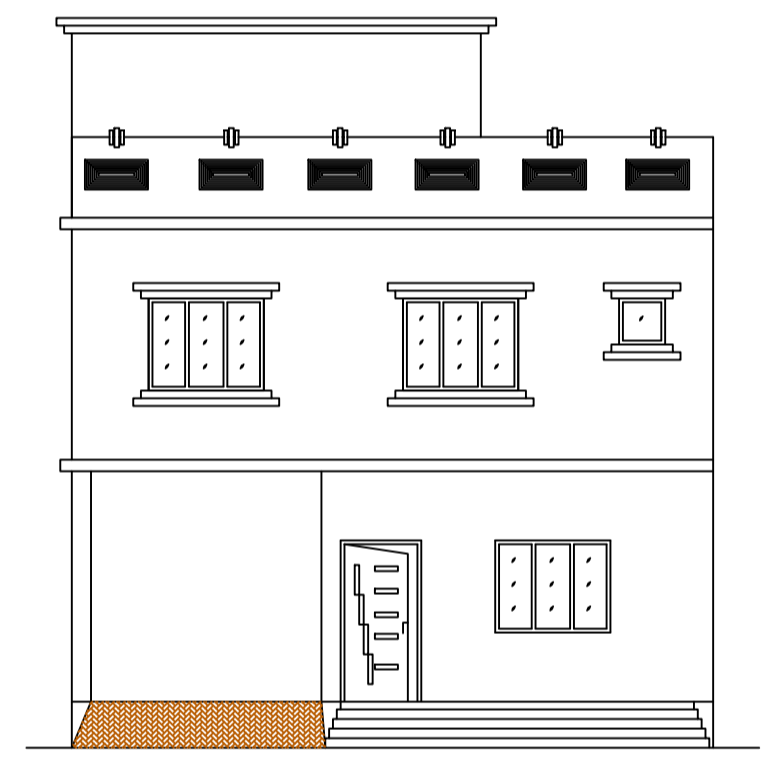

FRONT ELEVATION

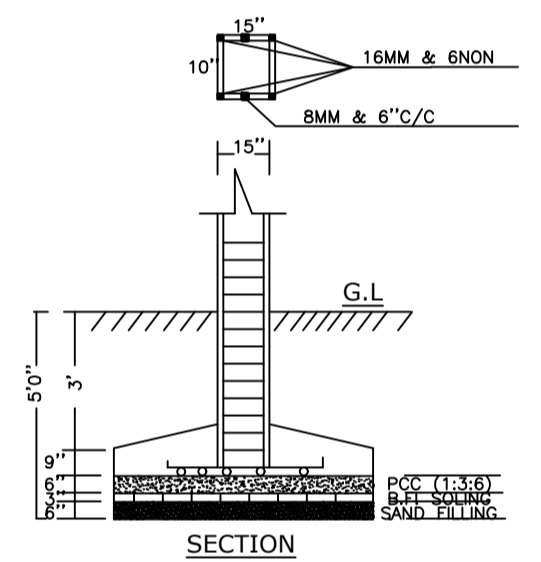

SECTION

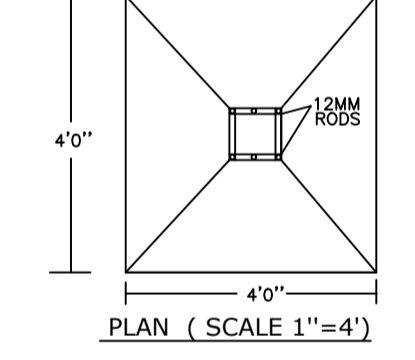

PLAN (SCALE 1''=4')

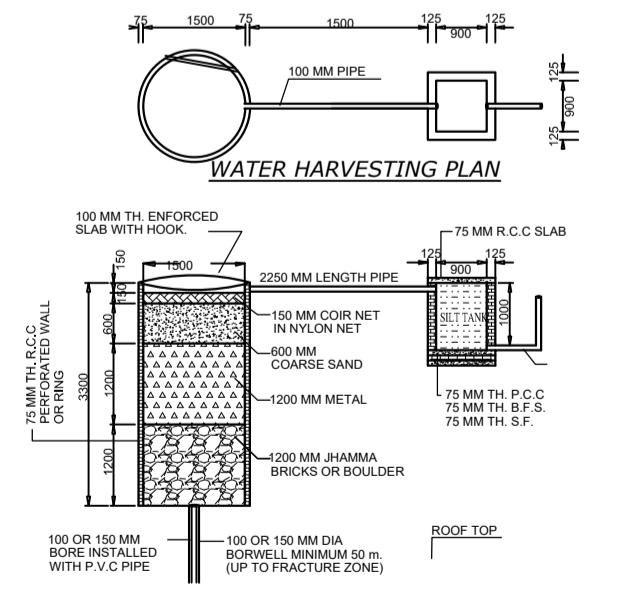

WATER HARVESTING PLAN

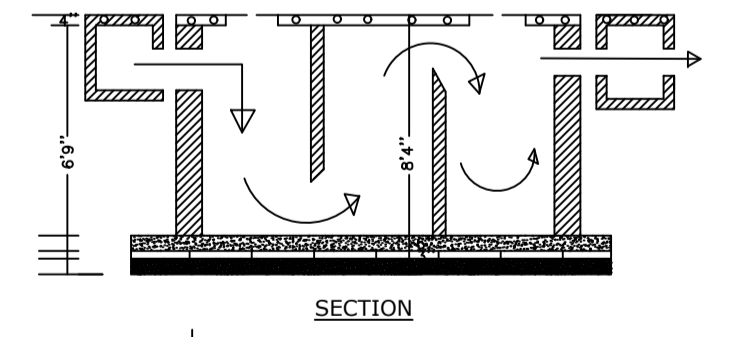

SECTION

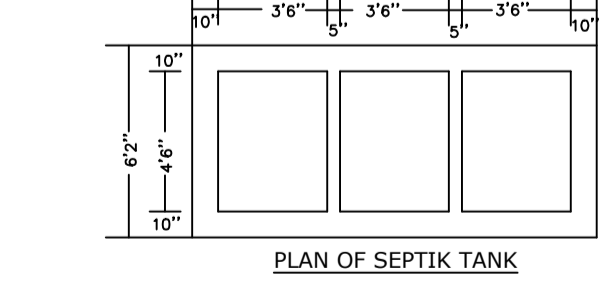

PLAN OF SEPTIC TANK

COLOR INDEX

PLOT BOUNDARY	Black
ABUTTING ROAD	Green
PROPOSED CONSTRUCTION	Red
COMMON PLOT	Yellow
ROAD WIDENING AREA	Blue
EXISTING (To be retained)	Orange
EXISTING (To be demolished)	White

Buildingwise Floor FAR Details

Floor Name	Building Name A (RESIDENTIAL)		Total	
	Proposed Built Up Area (Sq.mt.)	Proposed FAR Area (Sq.mt.)	Total Proposed Built Up Area (Sq.mt.)	Total FAR Area (Sq.mt.)
Ground Floor	69.21	69.21	69.21	69.21
First Floor	69.21	69.21	69.21	69.21
Terrace Floor	0.00	0.00	0.00	0.00
Total :	138.42	138.42	138.42	138.42

Building USE/SUBUSE Details

Building Name	Building Use	Building SubUse	Building Structure
A (RESIDENTIAL)	Residential	Bungalow/ Dwelling / Non Apartment	Non-Highrise

LTP NAME AND SIGNATURE	STRUCTURAL ENG'S NAME AND SIGNATURE	BUILDER NAME AND SIGNATURE	DIGITAL SIGNATURE
RANJIT KUMAR MNNP/ENG/0001/2016			