

Proposal Basic Information

Proposal File No.	MNNP/BP/0237/W23/2023
Owner Name	Kumari Pushpa
Khata No	106
Plot No	2380
Village Name	Belbatkar Redma
Use	Residential
SubUse	Bungalow Dwelling / Non Apartment

FAR & Tenement Details (Table 4c-1)

Building	No. of Same Bldg	Total Built Up Area (Sq.mt.)	Proposed FAR Area (Sq.mt.) Resi.	Total FAR Area (Sq.mt.)	Total Consumed Additional FAR Area (Sq.mt.)	Tnmt (No.)
A (BUILDING)	1	107.60	107.60	107.60	107.60	01
Grand Total :	1	107.60	107.60	107.60	107.60	01

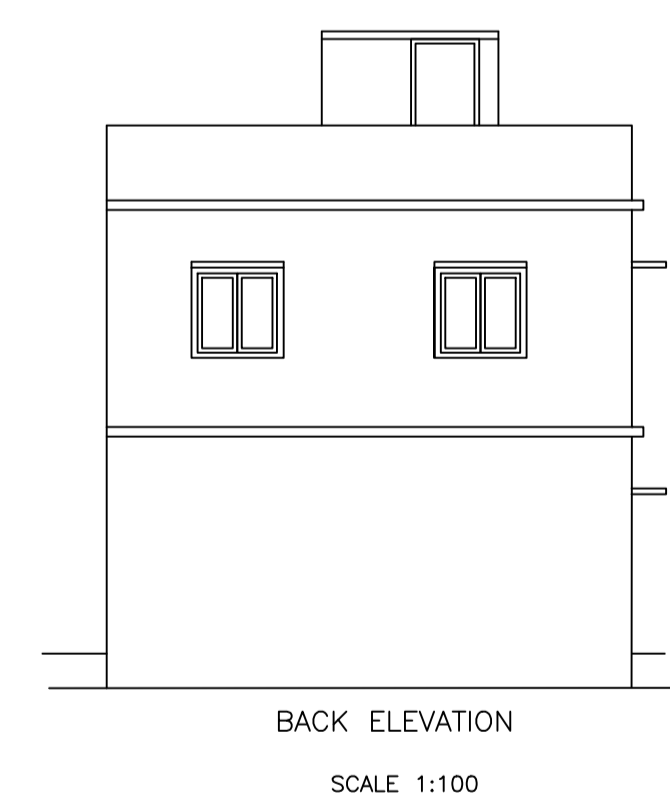
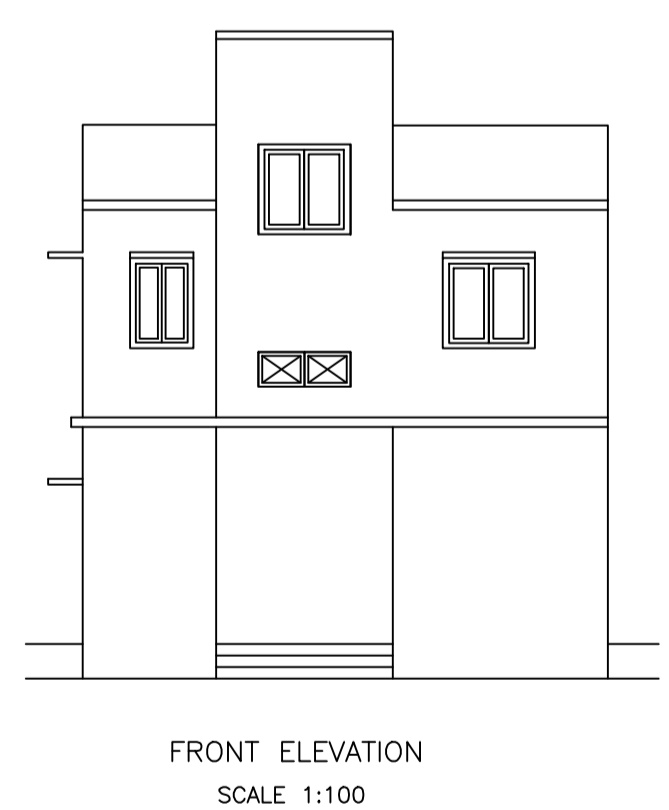
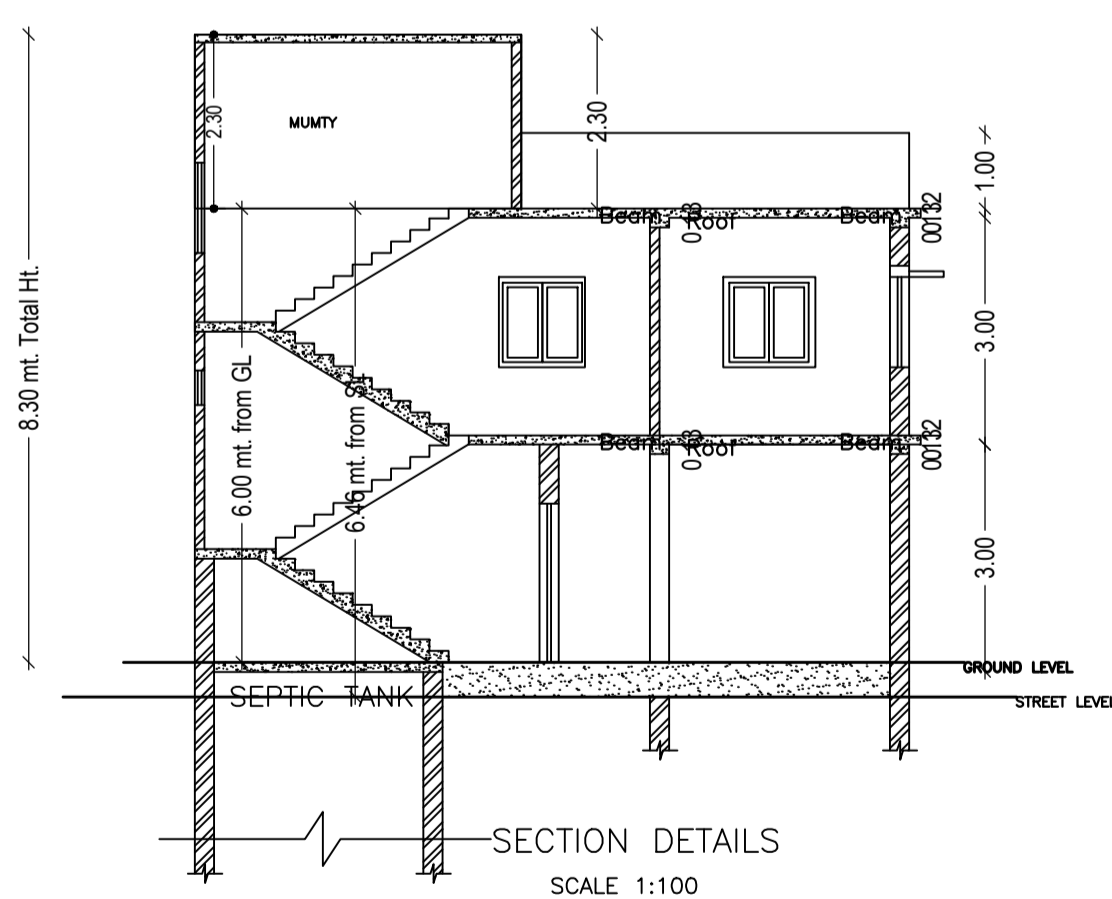
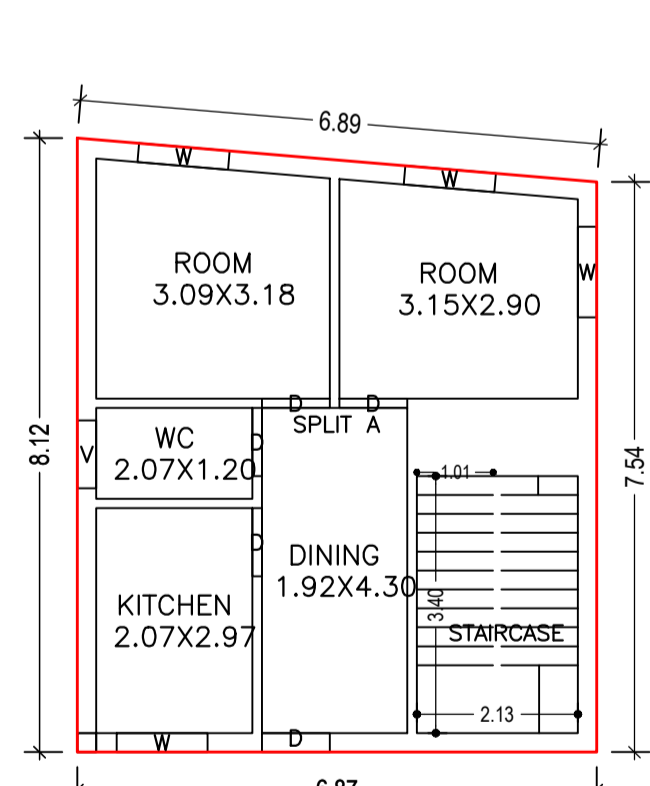
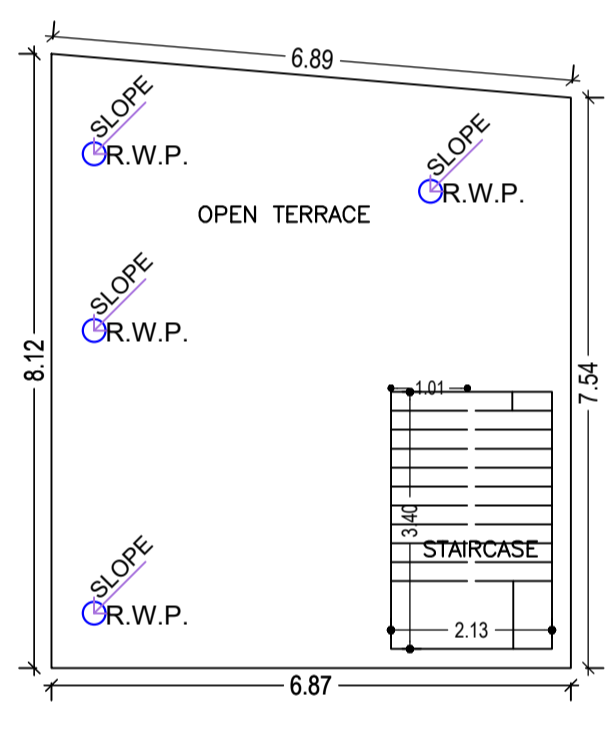
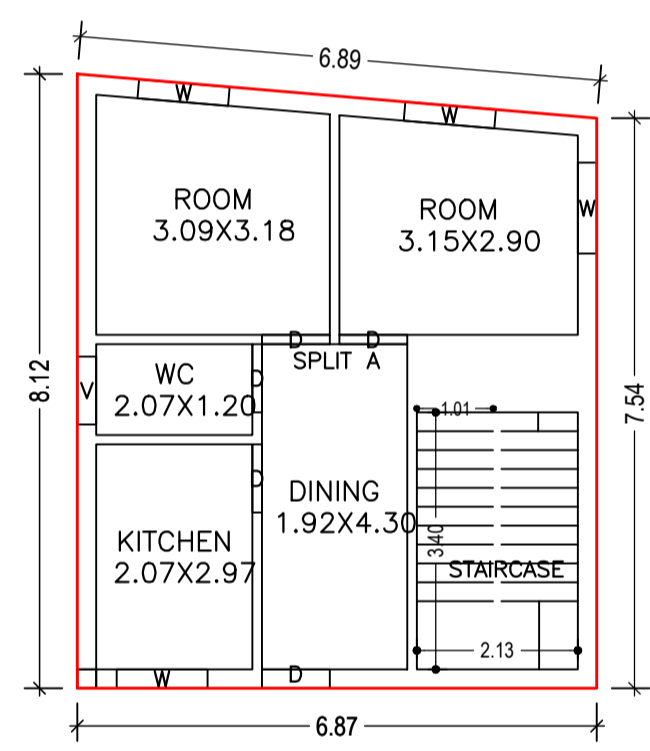
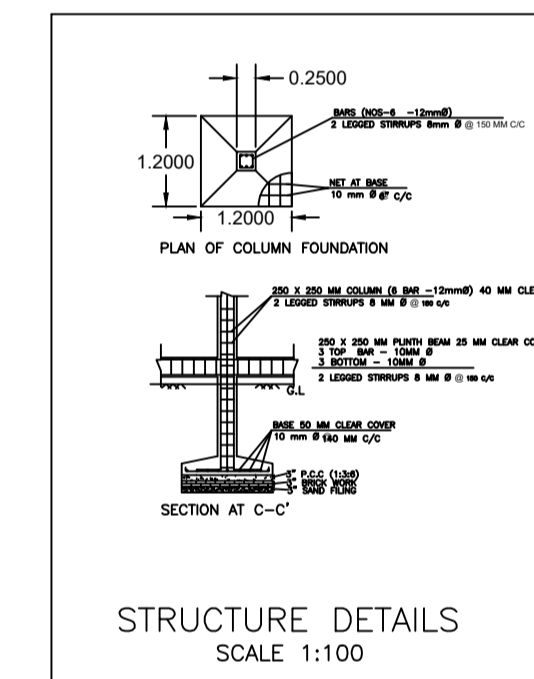
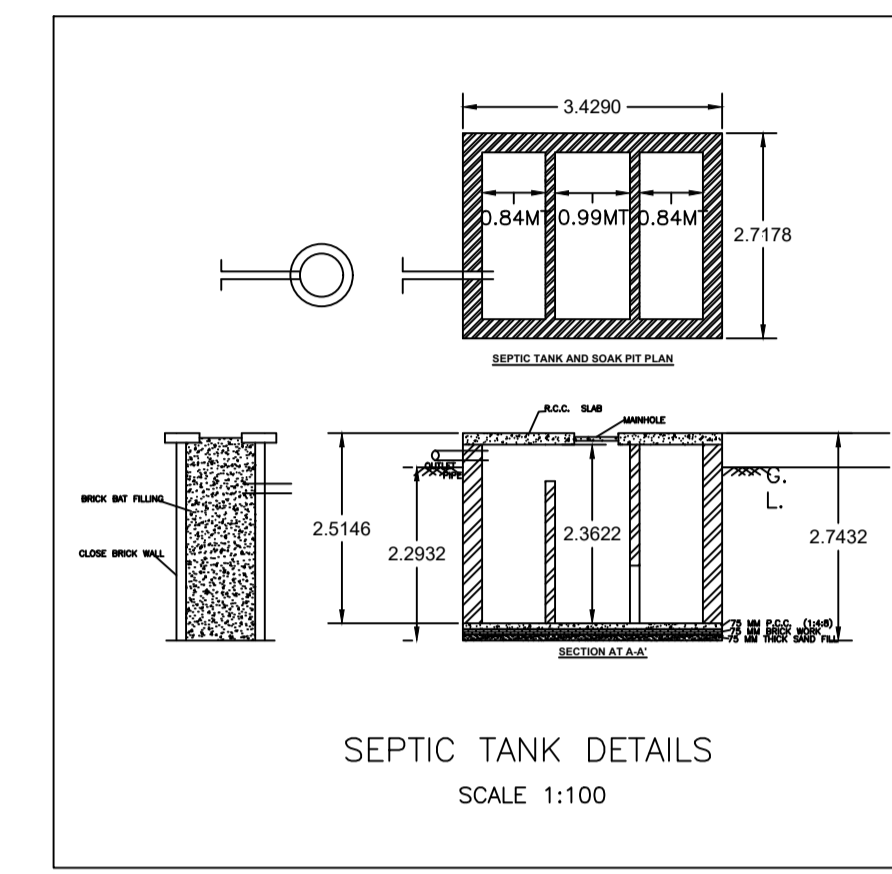
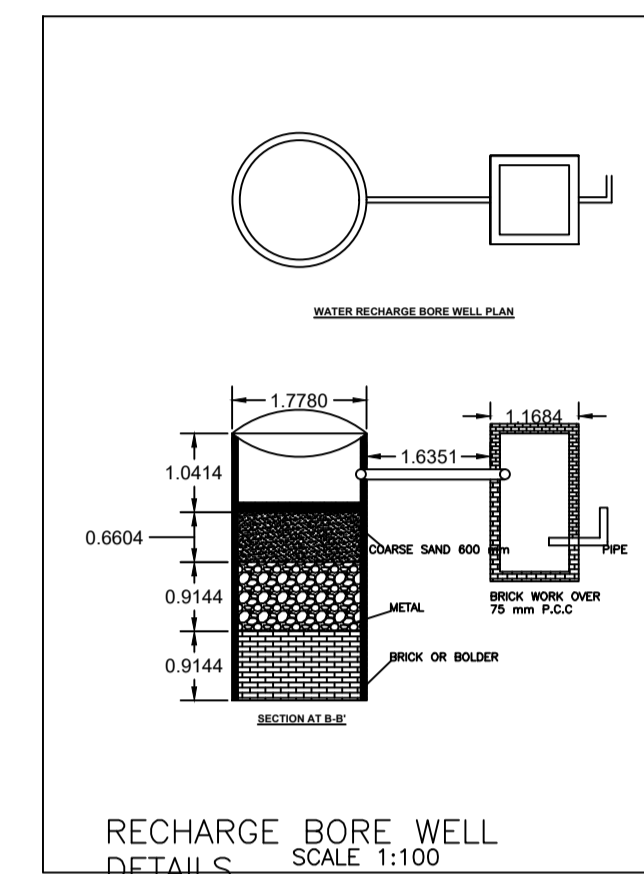
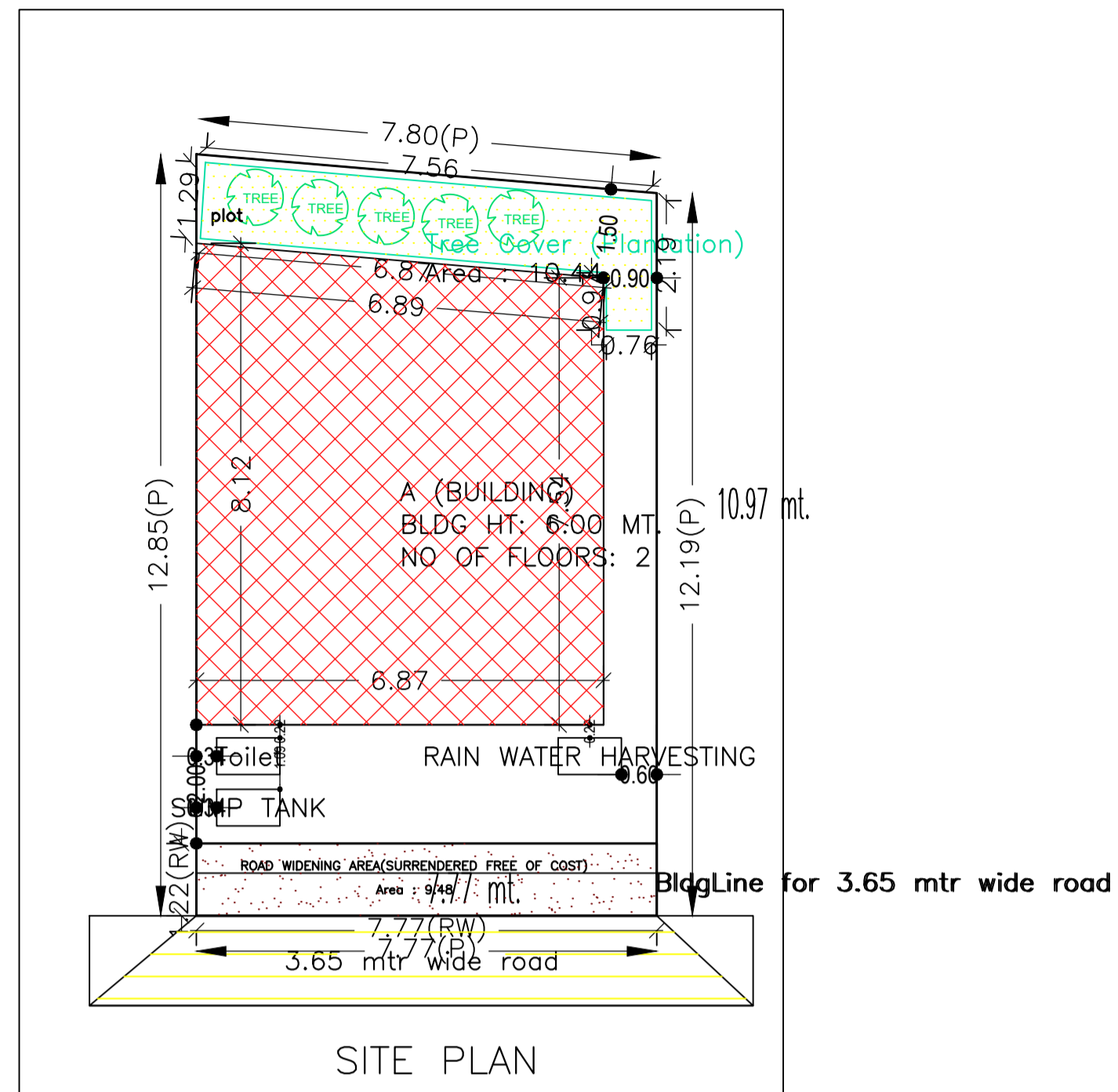

AREA STATEMENT	VERSION NO. : 1.0/68
MEDINAGAR MUNICIPAL CORPORATION	VERSION DATE: 16/10/2020
PROJECT DETAIL:	
Region : JHARKHAND URBAN	Plot Use: Residential
LOCAL BODIES	Plot SubUse: Bungalow Dwelling / Non Apartment
District : PALAMU	Plot/Nearby/Religious Structure: NA
Authority: MEDINAGAR MUNICIPAL CORPORATION	Plot/SubPlot No: 2380
Inward No: MNNP/BP/0237/W23/2023	North: -
Application Type: General Proposal	South: -
Project Type: Building Permission	East: -
Nature of Development: New	West: -
Location of Development Area: Old	
Area	SQ.MT.
AREA OF PLOT (Minimum)	(A) 97.27
Deduction for NetPlot Area	
Surrender Free of Cost	9.48
Total	9.48
NET AREA OF PLOT(Gross Plot Area - Deduction from Gross Plot area)	(A-Deductions) 87.79
Deduction for Balance Plot Area(from Gross Plot Area)	
Surrender Free of Cost	9.48
Common Plot	10.44
Total	19.92
BALANCE AREA OF PLOT(Net Plot Area - Recreational/Amenity space)	(A-Deductions) 77.35
PLOT AREA FOR COVERAGE(Net Plot Area)	(A-Deductions) 87.79
Plot Area for FAR (Net Plot Area + RoadWidening Area)	(A-Deductions) 97.27
COVERAGE CHECK	
Permissible Coverage area ( 70.00 % )	61.45
Proposed Coverage Area ( 61.28 % )	53.80
Total Prop. Coverage Area ( 61.28 % )	53.80
Balance coverage area ( 8.71 % )	7.65
FAR CHECK	
Perm. FAR Area ( 1.500 )	145.90
Total Perm. FAR area	145.90
Residential FAR	107.61
Proposed FAR Area	107.61
Total Proposed FAR Area	107.61
Consumed FAR (Factor)	1.11
Balance FAR Area	38.29
BUILT UP AREA CHECK	
Total Proposed BuiltUp Area	107.60
ARCHITECT (Regd)	PANKAJ KUMAR SINGH
ENGINEER (Regd)	
SUPERVISOR (Regd)	
OWNER (Regd)	Kumari Pushpa
DEVELOPMENT AUTHORITY LOCAL BODY	

COLOR INDEX	
PLOT BOUNDARY	Black
ABUTTING ROAD	Red
PROPOSED CONSTRUCTION	Green
COMMON PLOT	Yellow
ROAD WIDENING AREA	Blue
EXISTING (To be retained)	Orange
EXISTING (To be demolished)	Grey

Buildingwise Floor FAR Details

Floor Name	Building Name A (BUILDING)		Total	
	Proposed Built Up Area (Sq.mt.)	Proposed FAR Area (Sq.mt.)	Total Proposed Built Up Area (Sq.mt.)	Total FAR Area (Sq.mt.)
Ground Floor	53.80	53.80	53.80	53.80
First Floor	53.80	53.80	53.80	53.80
Terrace Floor	0.00	0.00	0.00	0.00
Total :	107.60	107.60	107.60	107.60

Building USE/SUBUSE Details

Building Name	Building Use	Building SubUse	Building Structure
A (BUILDING)	Residential	Bungalow Dwelling / Non Apartment	Non-Highrise

Floor Name	Total Built Up Area (Sq.mt.)	Proposed FAR Area (Sq.mt.) Resi.	Total FAR Area (Sq.mt.)	Total Consumed Additional FAR Area (Sq.mt.)	Tnmt (No.)
Ground Floor	53.80	53.80	53.80	53.80	01
First Floor	53.80	53.80	53.80	53.80	00
Terrace Floor	0.00	0.00	0.00	0.00	00
Total :	107.60	107.60	107.60	107.60	01
Total Number of Same Buildings :	1				
Total :	107.60	107.60	107.60	107.60	01

SCHEDULE OF DOOR:

BUILDING NAME	NAME	LENGTH	HEIGHT	NOS
A (BUILDING)	D	0.90	2.10	10

SCHEDULE OF WINDOW/VENTILATION:

BUILDING NAME	NAME	LENGTH	HEIGHT	NOS
A (BUILDING)	V	0.90	0.60	02
A (BUILDING)	W	1.20	1.20	08

UnitBUA Table for Building :A (BUILDING)

FLOOR	Name	UnitBUA Type	UnitBUA Area	Carpet Area	No. of Rooms	No. of Tenement
GROUND FLOOR PLAN	SPLIT A	FLAT	84.81	84.69	5	1
FIRST FLOOR PLAN	SPLIT A	FLAT	0.00	0.00	5	0
Total:	-	-	84.81	84.69	10	1

LTP NAME AND SIGNATURE	STRUCTURAL ENG'S NAME AND SIGNATURE	BUILDER NAME AND SIGNATURE	DIGITAL SIGNATURE
PANKAJ KUMAR SINGH MNNP/ENG/006/2019			