

SITE PLAN

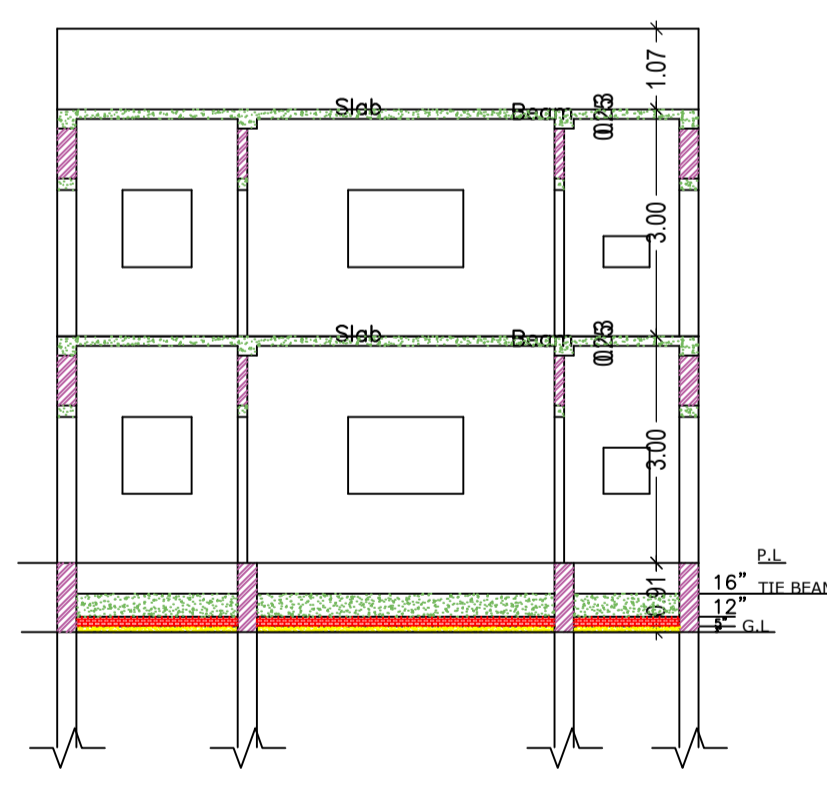
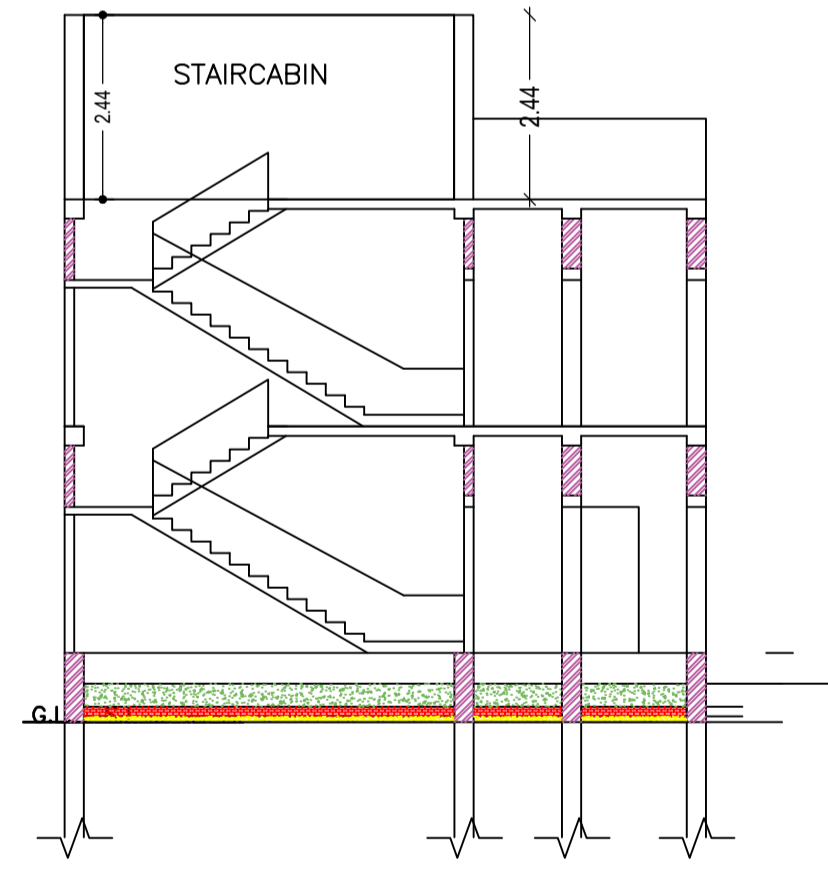
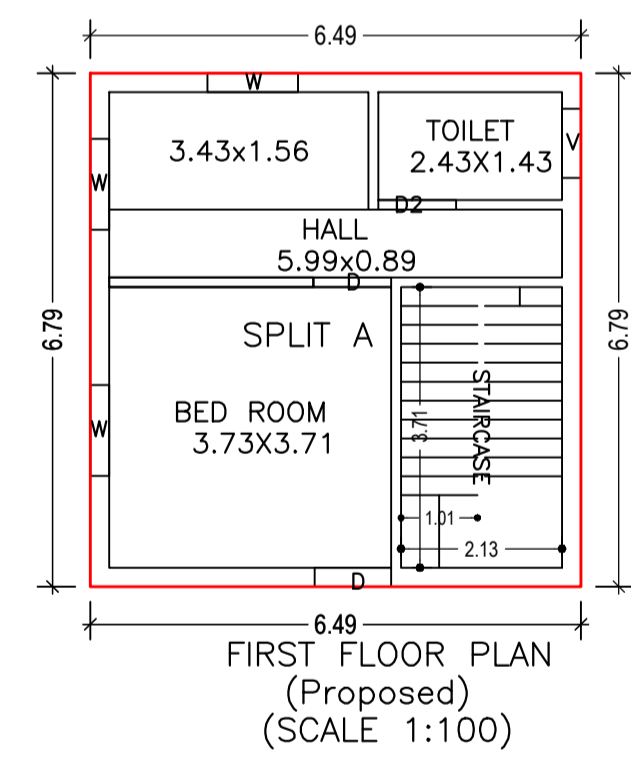
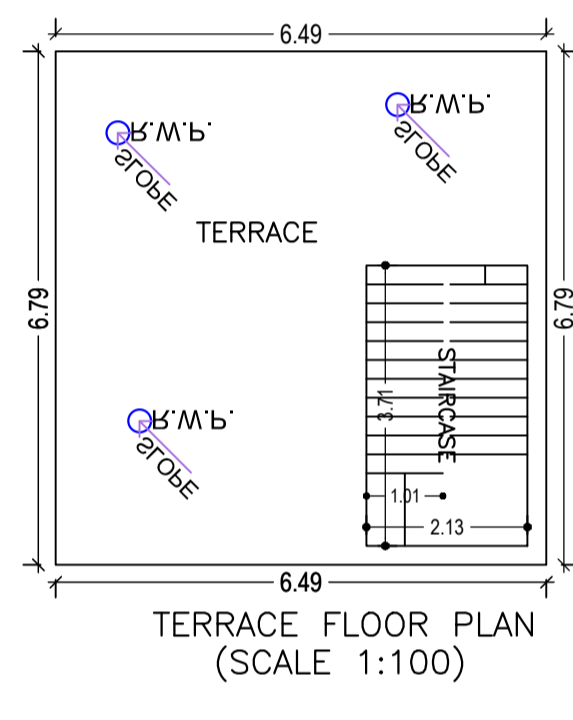
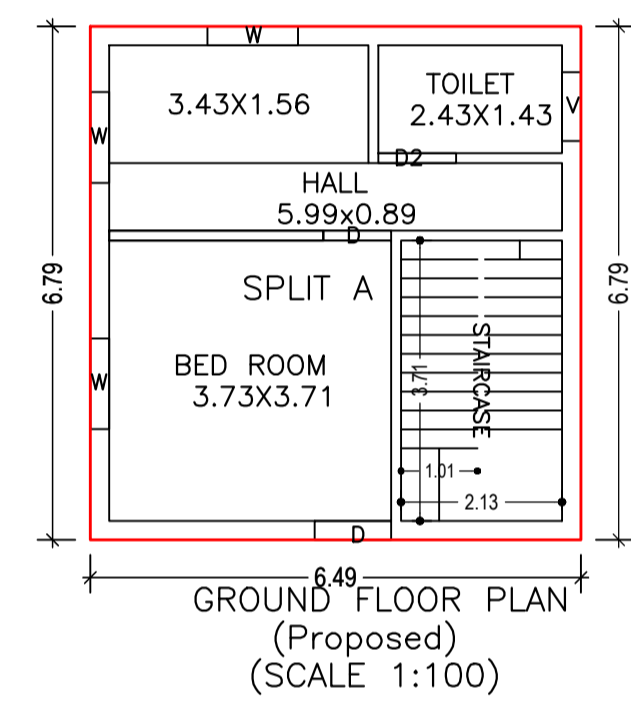

Building :A (RESIDENTIAL)

Floor Name	Total Built Up Area (Sq.mt.)	Proposed FAR Area (Sq.mt.)	Total FAR Area (Sq.mt.)	Total Consumed Additional FAR Area (Sq.mt.)	Tnmt (No.)
Ground Floor	44.07	44.07	44.07	44.07	01
First Floor	44.07	44.07	44.07	44.07	00
Terrace Floor	0.00	0.00	0.00	0.00	00
<b>Total :</b>	<b>88.14</b>	<b>88.14</b>	<b>88.14</b>	<b>88.14</b>	<b>01</b>
Total Number of Same Buildings :	1				
<b>Total :</b>	<b>88.14</b>	<b>88.14</b>	<b>88.14</b>	<b>88.14</b>	<b>01</b>

SCHEDULE OF DOOR:

BUILDING NAME	NAME	LENGTH	HEIGHT	NOS
A (RESIDENTIAL)	D	0.90	2.10	01
A (RESIDENTIAL)	D	1.01	2.10	02
A (RESIDENTIAL)	D	1.03	2.10	01
A (RESIDENTIAL)	D2	1.03	2.10	02

SCHEDULE OF WINDOW/VENTILATION:

BUILDING NAME	NAME	LENGTH	HEIGHT	NOS
A (RESIDENTIAL)	V	0.91	0.90	02
A (RESIDENTIAL)	W	1.20	1.20	06

UnitBUA Table for Building :A (RESIDENTIAL)

FLOOR	Name	UnitBUA Type	UnitBUA Area	Carpet Area	No. of Rooms	No. of Tenement
FIRST FLOOR PLAN	SPLIT A	FLAT	0.00	0.00	3	0
GROUND FLOOR PLAN	SPLIT A	FLAT	68.67	67.95	3	1
<b>Total:</b>	-	-	<b>68.67</b>	<b>67.95</b>	<b>6</b>	<b>1</b>

FAR & Tenement Details (Table 4c-1)

Building	No. of Same Bldg	Total Built Up Area (Sq.mt.)	Proposed FAR Area (Sq.mt.) Resi.	Total FAR Area (Sq.mt.)	Total Consumed Additional FAR Area (Sq.mt.)	Tnmt (No.)
A (RESIDENTIAL)	1	88.14	88.14	88.14	88.14	01
<b>Grand Total :</b>	<b>1</b>	<b>88.14</b>	<b>88.14</b>	<b>88.14</b>	<b>88.14</b>	<b>01</b>

Proposal Basic Information

Proposal File No.	MNNP/BP/0221/W06/2023
Owner Name	PRITI KUMARI
Khata No	98
Plot No	700
Village Name	Baralota
Use	Residential
SubUse	Bungalow/ Dwelling / Non Apartment

AREA STATEMENT		VERSION NO. : 1.0.68
MEDINAGAR MUNICIPAL CORPORATION		VERSION DATE: 16/10/2020
PROJECT DETAIL:		
Region : JHARKHAND URBAN LOCAL BODIES	Plot Use: Residential	
District: PALAMU	Plot SubUse: Bungalow/ Dwelling / Non Apartment	
Authority: MEDINAGAR MUNICIPAL CORPORATION	PlotNearbyReligiousStructure: NA	
Inward No: MNNP/BP/0221/W06/2023	Plot/SubPlot No: 700	
Application Type: General Proposal	North: -	
Project Type: Building Permission	South: -	
Nature of Development: New	East: -	
Location of Development Area: Old Area	West: -	
AREA DETAILS:		
AREA OF PLOT (Minimum)	(A)	SQ.MT. 91.08
Deduction for NetPlot Area		
Surrender Free of Cost		8.01
Total		8.01
NET AREA OF PLOT(Gross Plot Area - Deduction from Gross Plot area)	(A-Deductions)	83.07
Deduction for Balance Plot Area(from Gross Plot Area)		
Surrender Free of Cost		8.01
Common Plot		13.49
Total		21.50
BALANCE AREA OF PLOT(Net Plot Area - Recreational/Amenity space)	(A-Deductions)	69.58
PLOT AREA FOR COVERAGE(Net Plot Area)	(A-Deductions)	83.07
Plot Area for FAR (Net Plot Area + RoadWidening Area)	(A-Deductions)	91.08
COVERAGE CHECK		
Permissible Coverage area ( 70.00 % )		58.15
Proposed Coverage Area ( 53.05 % )		44.07
Total Prop. Coverage Area ( 53.05 % )		44.07
Balance coverage area ( 16.95 % )		14.08
FAR CHECK		
Perm. FAR Area ( 1.500 )		136.62
Total Perm. FAR area		136.62
Residential FAR		88.13
Proposed FAR Area		88.13
Total Proposed FAR Area		88.13
Consumed FAR (Factor)		0.97
Balance FAR Area		48.49
BUILT UP AREA CHECK		
Total Proposed BuiltUp Area		88.14
ARCHITECT (Regd)		RANJIT KUMAR
ENGINEER (Regd)		
SUPERVISOR (Regd)		
OWNER (Regd)		PRITI KUMARI
DEVELOPMENT AUTHORITY		LOCAL BODY

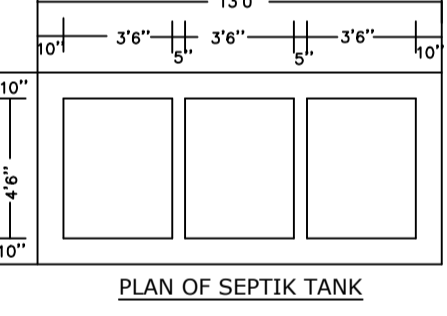
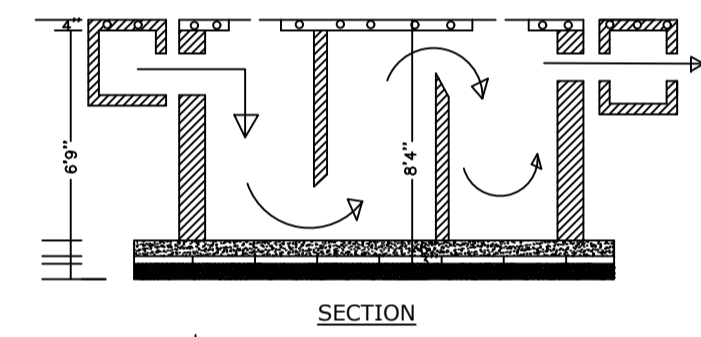
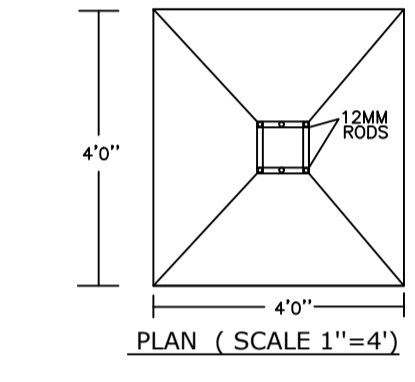
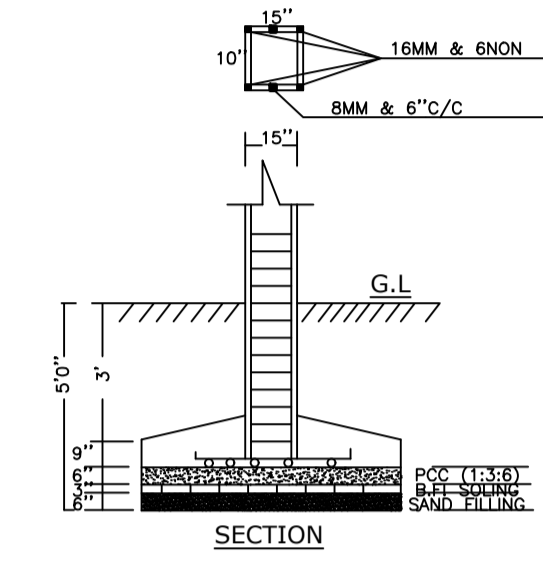

COLOR INDEX	
PLOT BOUNDARY	[Red Line]
ABUTTING ROAD	[Green Line]
PROPOSED CONSTRUCTION	[Yellow Line]
COMMON PLOT	[Blue Line]
ROAD WIDENING AREA	[Orange Line]
EXISTING (To be retained)	[Grey Line]
EXISTING (To be demolished)	[Black Line]

Buildingwise Floor FAR Details

Floor Name	Building Name A (RESIDENTIAL)		Total	
	Proposed Built Up Area (Sq.mt.)	Proposed FAR Area (Sq.mt.)	Total Proposed Built Up Area (Sq.mt.)	Total FAR Area (Sq.mt.)
Ground Floor	44.07	44.07	44.07	44.07
First Floor	44.07	44.07	44.07	44.07
Terrace Floor	0.00	0.00	0.00	0.00
<b>Total :</b>	<b>88.14</b>	<b>88.14</b>	<b>88.14</b>	<b>88.14</b>

Building USE/SUBUSE Details

Building Name	Building Use	Building SubUse	Building Structure
A (RESIDENTIAL)	Residential	Bungalow/ Dwelling / Non Apartment	Non-Highrise

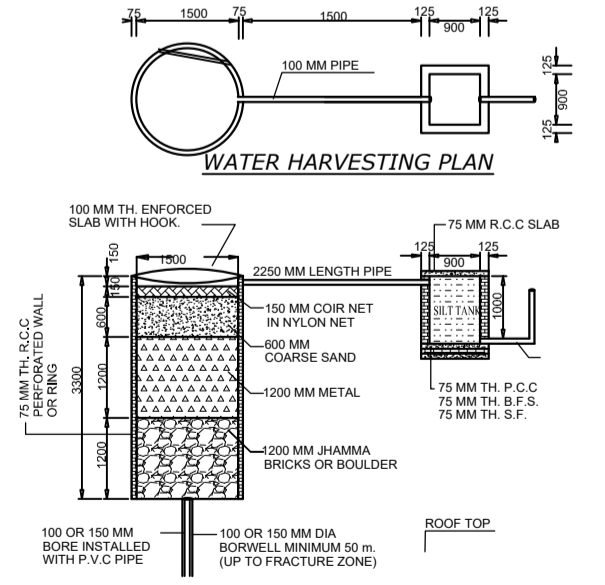

LTP NAME AND SIGNATURE	STRUCTURAL ENG'S NAME AND SIGNATURE	BUILDER NAME AND SIGNATURE	DIGITAL SIGNATURE
RANJIT KUMAR MNNP/ENG/0001/2016			