

GROUND FLOOR PLAN (Proposed) (SCALE 1:100)

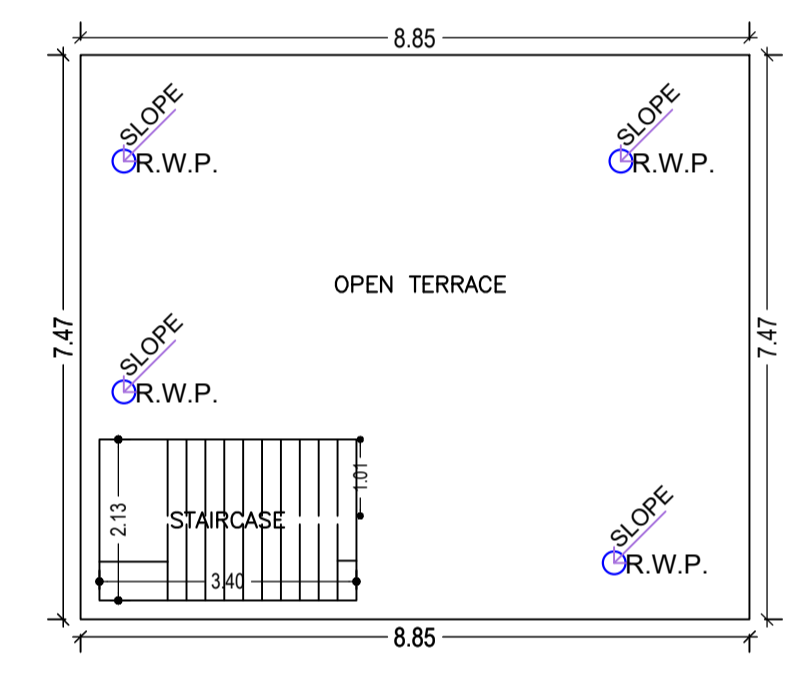

TERRACE FLOOR PLAN (SCALE 1:100)

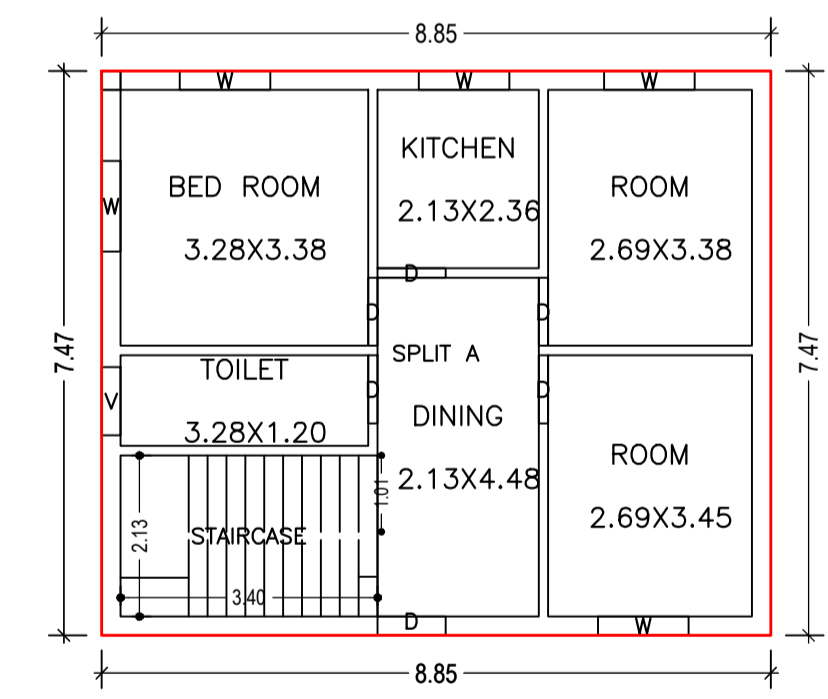

FIRST FLOOR PLAN (Proposed) (SCALE 1:100)

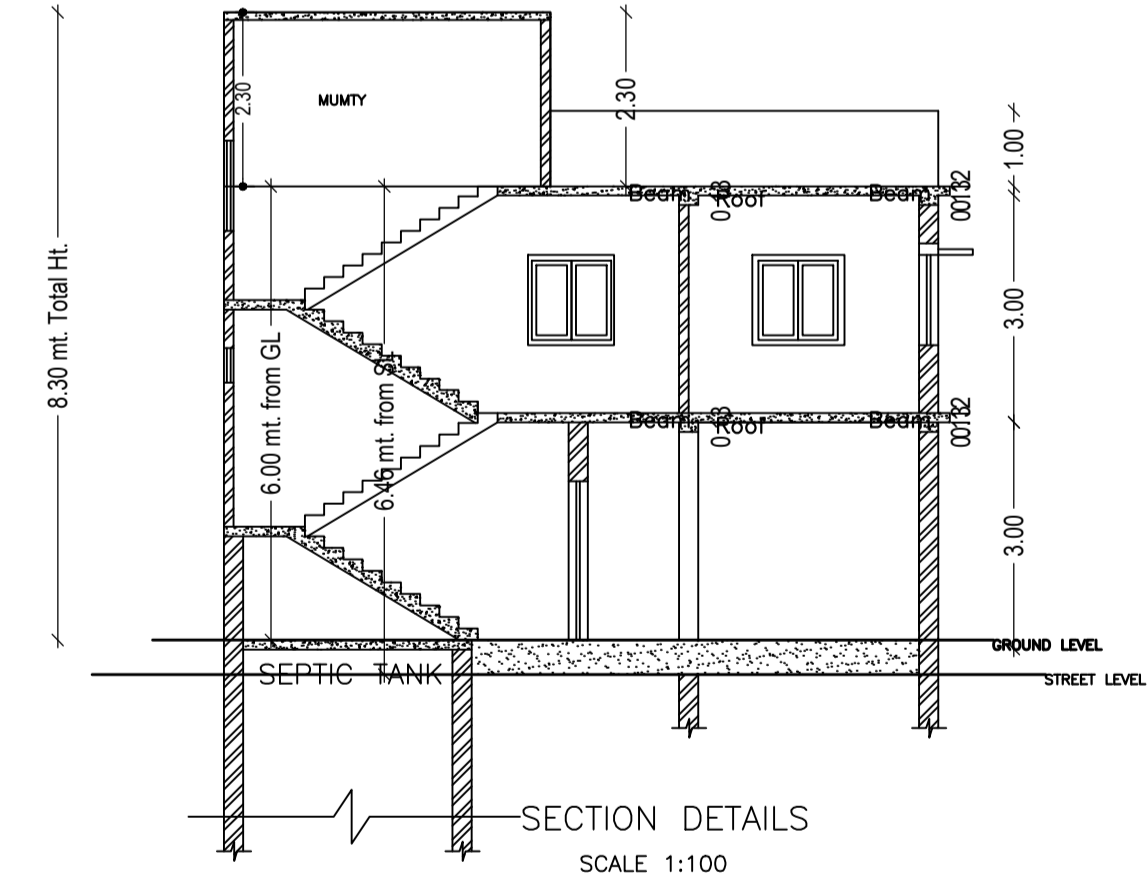

SECTION DETAILS (SCALE 1:100)

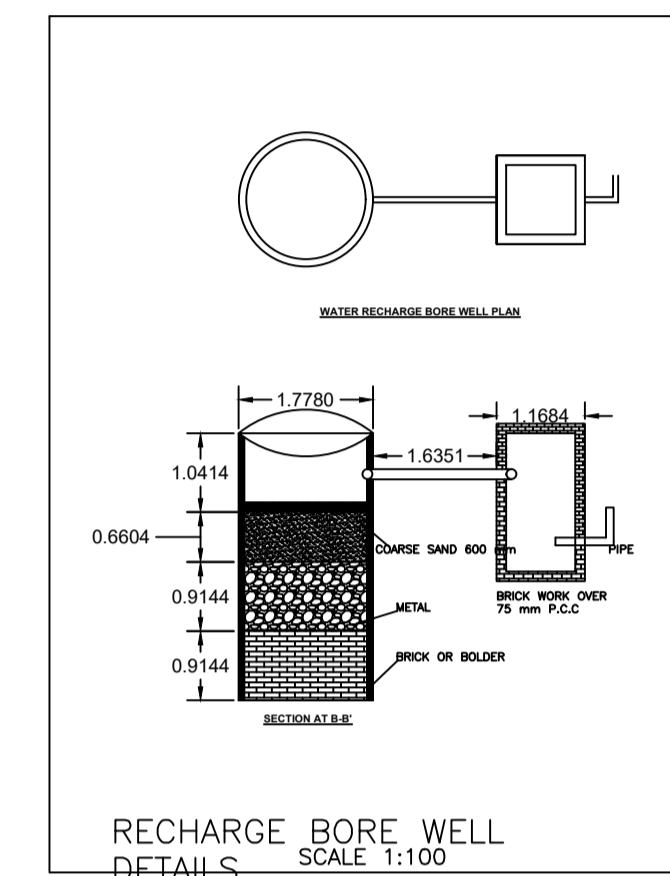

RECHARGE BORE WELL DETAILS (SCALE 1:100)

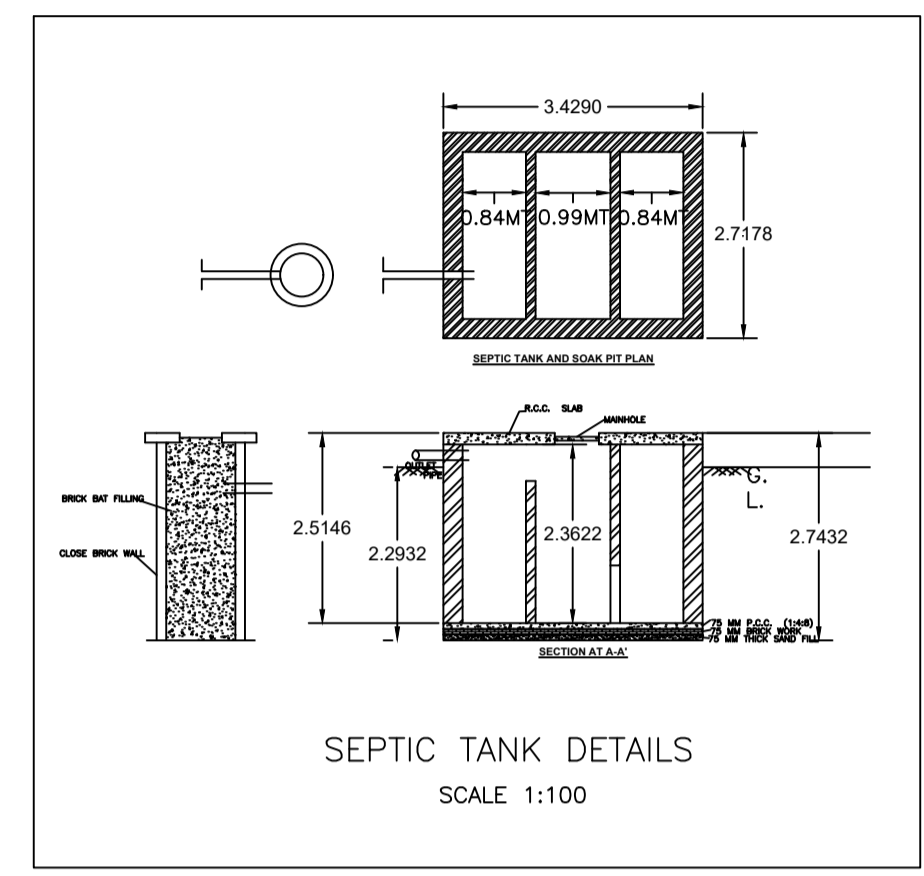

SEPTIC TANK DETAILS (SCALE 1:100)

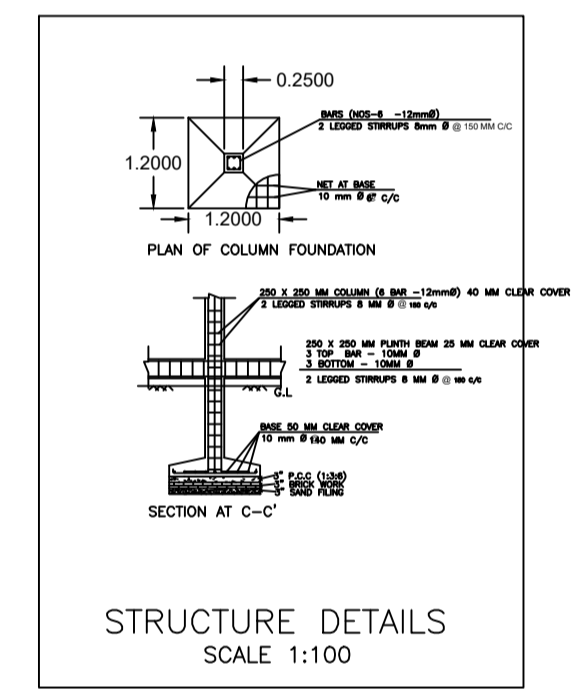

STRUCTURE DETAILS (SCALE 1:100)

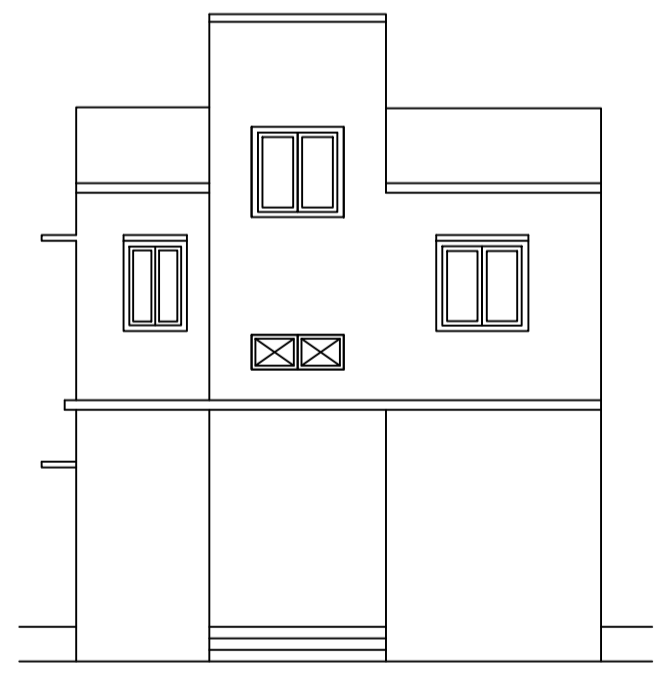

FRONT ELEVATION (SCALE 1:100)

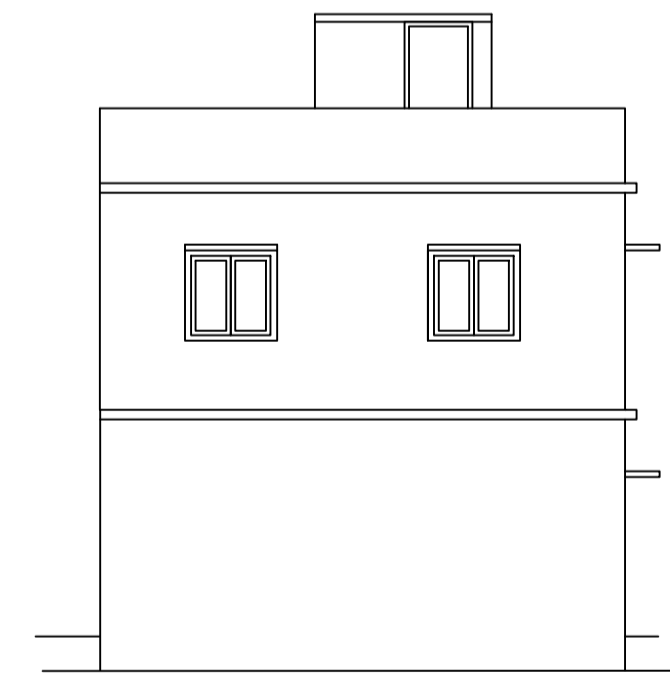

BACK ELEVATION (SCALE 1:100)

FAR & Tenement Details (Table 4c-1)

Building	No. of Same Bldg	Total Built Up Area (Sq.mt.)	Proposed FAR Area (Sq.mt.) Resi.	Total FAR Area (Sq.mt.)	Total Consumed Additional FAR Area (Sq.mt.)	Tnmt (No.)
A (BUILDING)	1	132.14	132.14	132.14	132.14	01
Grand Total :	1	132.14	132.14	132.14	132.14	01

Proposal Basic Information

Proposal File No.	MNNP/BP/0179/W17/2023
Owner Name	MAHENDRA MAHTO
Khata No	252
Plot No	1585
Village Name	Redma
Use	Residential
SubUse	Bungalow/ Dwelling / Non Apartment

AREA STATEMENT MEDININAGAR MUNICIPAL CORPORATION	VERSION NO. : 1.0.66 VERSION DATE: 16/10/2020
PROJECT DETAIL:	
Region: JHARKHAND URBAN LOCAL BODIES	Plot Use: Residential
District: PALAMU	Plot SubUse: Bungalow/ Dwelling / Non Apartment
Authority: MEDININAGAR MUNICIPAL CORPORATION	PlotNearby/Religious/Structure: NA
Inward No: MNNP/BP/0179/W17/2023	Plot/SubPlot No: 1585
Application Type: General Proposal	North: -
Project Type: Building Permission	South: -
Nature of Development: New	East: -
Location of Development Area: Old Area	West: -
AREA DETAILS:	SQ.MT.
AREA OF PLOT (Minimum)	(A) 118.85
Deduction for NetPlot Area	
Surrender Free of Cost	11.94
Total	11.94
NET AREA OF PLOT(Gross Plot Area - Deduction from Gross Plot area)	(A-Deductions) 106.91
Deduction for Balance Plot Area(from Gross Plot Area)	
Surrender Free of Cost	11.94
Common Plot	14.03
Total	25.97
BALANCE AREA OF PLOT(Net Plot Area - Recreational/Amenity space)	(A-Deductions) 92.88
PLOT AREA FOR COVERAGE(Net Plot Area)	(A-Deductions) 106.91
Plot Area for FAR (Net Plot Area + Road/Widening Area)	(A-Deductions) 118.85
COVERAGE CHECK	
Permissible Coverage area (70.00 %)	74.84
Proposed Coverage Area (61.80 %)	66.07
Total Prop. Coverage Area (61.8 %)	66.07
Balance coverage area (8.20 %)	8.77
FAR CHECK	
Perm. FAR Area (1.500)	178.27
Total Perm. FAR area	178.27
Residential FAR	132.13
Proposed FAR Area	132.13
Total Proposed FAR Area	132.13
Consumed FAR (Factor)	1.111
Balance FAR Area	46.14
BUILT UP AREA CHECK	
Total Proposed BuiltUp Area	132.14
ARCHITECT (Regd)	PANKAJ KUMAR SINGH
ENGINEER (Regd)	
SUPERVISOR (Regd)	
OWNER (Regd)	MAHENDRA MAHTO
DEVELOPMENT AUTHORITY	LOCAL BODY

COLOR INDEX	
PLOT BOUNDARY	Black
ABUTTING ROAD	Green
PROPOSED CONSTRUCTION	Red
COMMON PLOT	Yellow
ROAD WIDENING AREA	Blue
EXISTING (To be retained)	Grey
EXISTING (To be demolished)	White

Buildingwise Floor FAR Details

Floor Name	Building Name A (BUILDING)		Total	
	Proposed Built Up Area (Sq.mt.)	Proposed FAR Area (Sq.mt.)	Total Proposed Built Up Area (Sq.mt.)	Total FAR Area (Sq.mt.)
Ground Floor	66.07	66.07	66.07	66.07
First Floor	66.07	66.07	66.07	66.07
Terrace Floor	0.00	0.00	0.00	0.00
Total :	132.14	132.14	132.14	132.14

Building USE/SUBUSE Details

Building Name	Building Use	Building SubUse	Building Structure
A (BUILDING)	Residential	Bungalow/ Dwelling / Non Apartment	Non-Highrise

Building :A (BUILDING)

Floor Name	Total Built Up Area (Sq.mt.)	Proposed FAR Area (Sq.mt.) Resi.	Total FAR Area (Sq.mt.)	Total Consumed Additional FAR Area (Sq.mt.)	Tnmt (No.)
Ground Floor	66.07	66.07	66.07	66.07	01
First Floor	66.07	66.07	66.07	66.07	00
Terrace Floor	0.00	0.00	0.00	0.00	00
Total :	132.14	132.14	132.14	132.14	01
Total Number of Same Buildings	1				
Total :	132.14	132.14	132.14	132.14	01

SCHEDULE OF DOOR:

BUILDING NAME	NAME	LENGTH	HEIGHT	NOS
A (BUILDING)	D	0.90	2.10	12

SCHEDULE OF WINDOW/VENTILATION:

BUILDING NAME	NAME	LENGTH	HEIGHT	NOS
A (BUILDING)	V	0.90	0.60	02
A (BUILDING)	W	1.20	1.20	10

UnitBUA Table for Building :A (BUILDING)

FLOOR	Name	UnitBUA Type	UnitBUA Area	Carpet Area	No. of Rooms	No. of Tenement
GROUND FLOOR PLAN	SPLIT A	FLAT	114.76	114.63	6	1
FIRST FLOOR PLAN	SPLIT A	FLAT	0.00	0.00	6	0
Total:	-	-	114.76	114.63	12	1

LTP NAME AND SIGNATURE	STRUCTURAL ENG'S NAME AND SIGNATURE	BUILDER NAME AND SIGNATURE	DIGITAL SIGNATURE
PANKAJ KUMAR SINGH MNNP/ENG/0006/2019			