

SITE PLAN

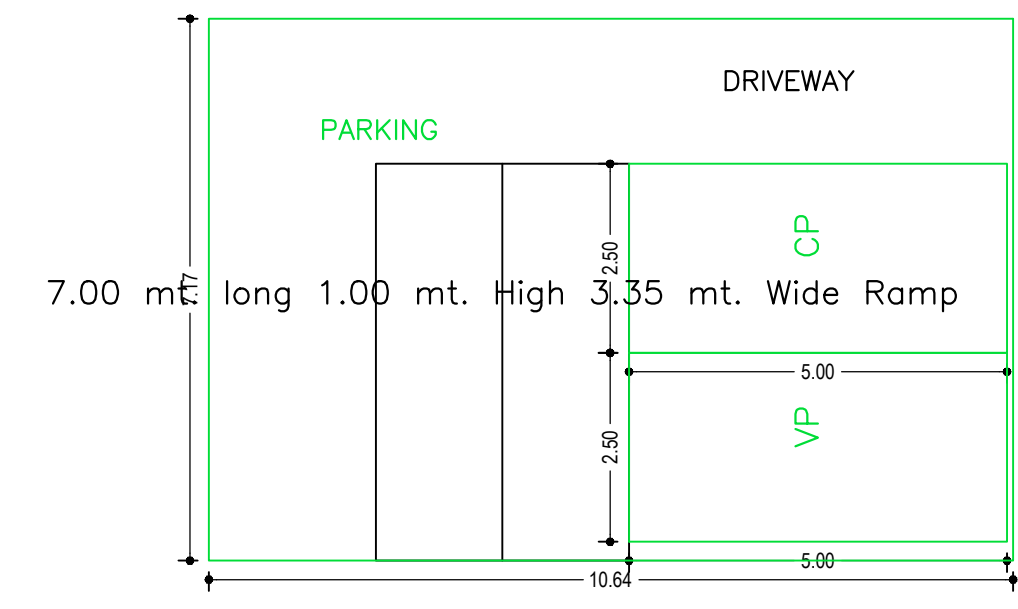

BASEMENT FLOOR PLAN (SCALE 1:100)

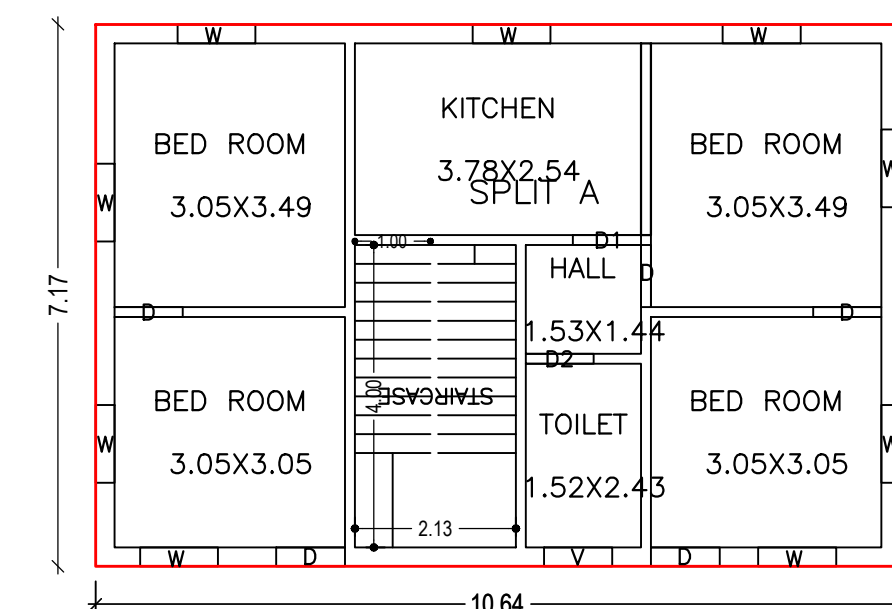

FIRST FLOOR PLAN (Proposed) (SCALE 1:100)

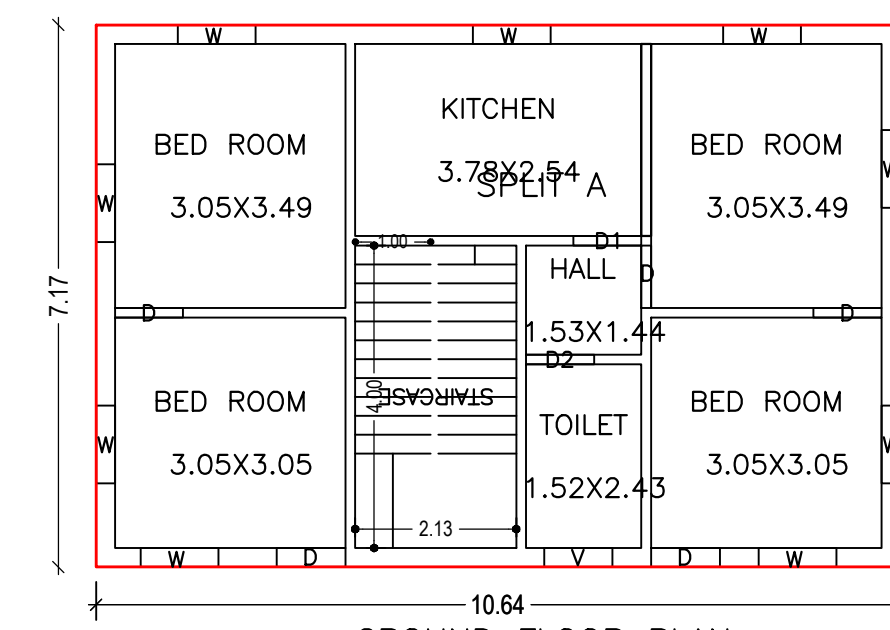

GROUND FLOOR PLAN (Proposed) (SCALE 1:100)

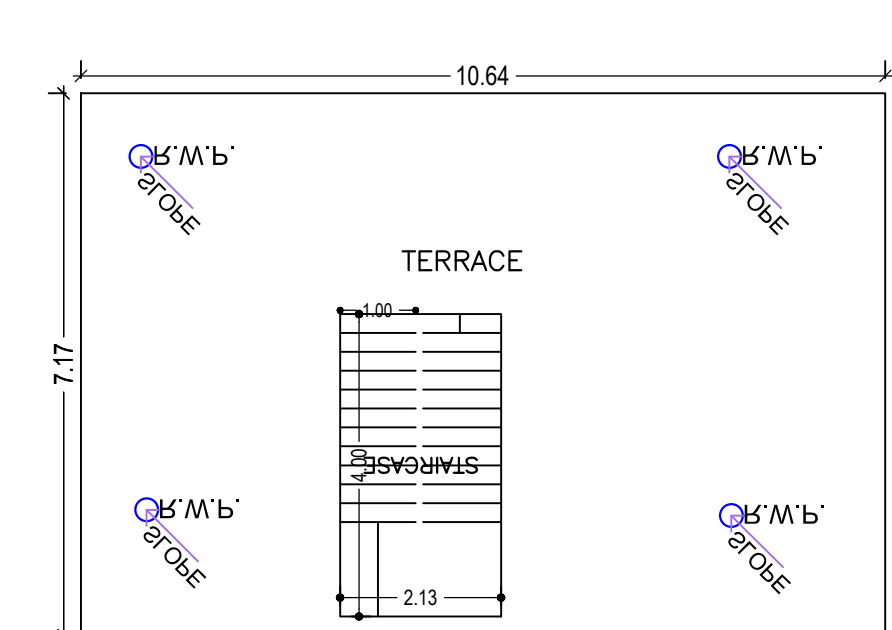

TERRACE FLOOR PLAN (SCALE 1:100)

Building :A (RESICOMM)

Floor Name	Total Built Up Area (Sq.mt.)	Deductions (Area in Sq.mt.)		Proposed FAR Area (Sq.mt.)	Total FAR Area (Sq.mt.)	Total Consumed Additional FAR Area (Sq.mt.)	Trmnt (No.)
		Parking	Resi.				
Basement Floor	76.29	58.70	0.00	0.00	0.00	0.00	00
Ground Floor	76.29	0.00	76.29	76.29	76.29	76.29	01
First Floor	76.29	0.00	76.29	76.29	76.29	76.29	00
Terrace Floor	0.00	0.00	0.00	0.00	0.00	0.00	00
<b>Total :</b>	<b>228.87</b>	<b>58.70</b>	<b>152.58</b>	<b>152.58</b>	<b>152.58</b>	<b>152.58</b>	<b>01</b>
Total Number of Same Buildings	1						
<b>Total :</b>	<b>228.87</b>	<b>58.70</b>	<b>152.58</b>	<b>152.58</b>	<b>152.58</b>	<b>152.58</b>	<b>01</b>

SCHEDULE OF DOOR:

BUILDING NAME	NAME	LENGTH	HEIGHT	NOS
A (RESICOMM)	D	0.82	2.10	02
A (RESICOMM)	D	0.90	2.10	04
A (RESICOMM)	D1	0.90	2.10	02
A (RESICOMM)	D2	0.90	2.10	02
A (RESICOMM)	D	0.91	2.10	04

SCHEDULE OF WINDOW/VENTILATION:

BUILDING NAME	NAME	LENGTH	HEIGHT	NOS
A (RESICOMM)	V	0.90	0.60	02
A (RESICOMM)	W	1.03	1.20	18

UnitBUA Table for Building :A (RESICOMM)

FLOOR	Name	UnitBUA Type	UnitBUA Area	Carpet Area	No. of Rooms	No. of Tenement
GROUND FLOOR PLAN	SPLIT A	FLAT	134.47	133.81	7	1
FIRST FLOOR PLAN	SPLIT A	FLAT	0.00	0.00	7	0
<b>Total:</b>	-	-	<b>134.47</b>	<b>133.81</b>	<b>14</b>	<b>1</b>

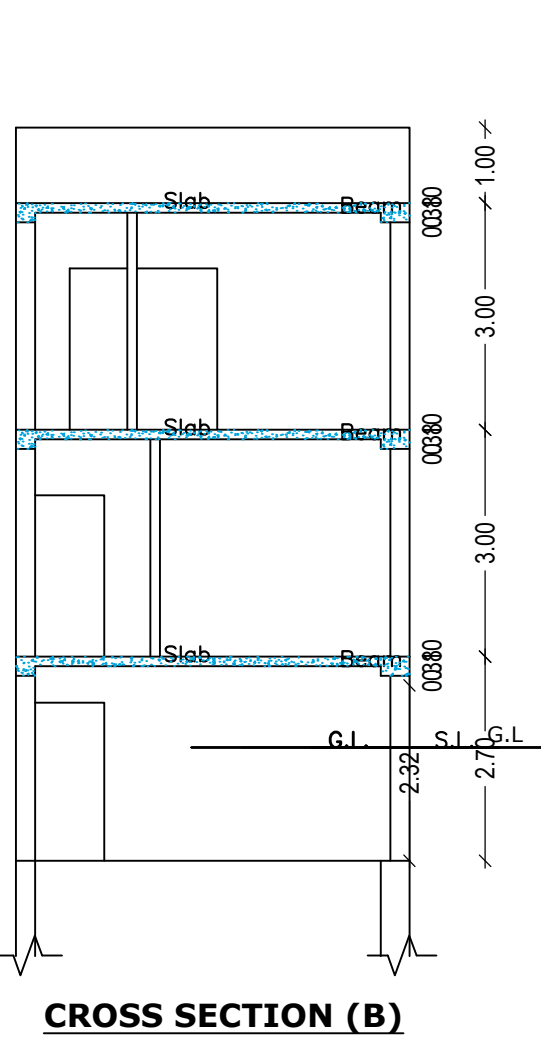
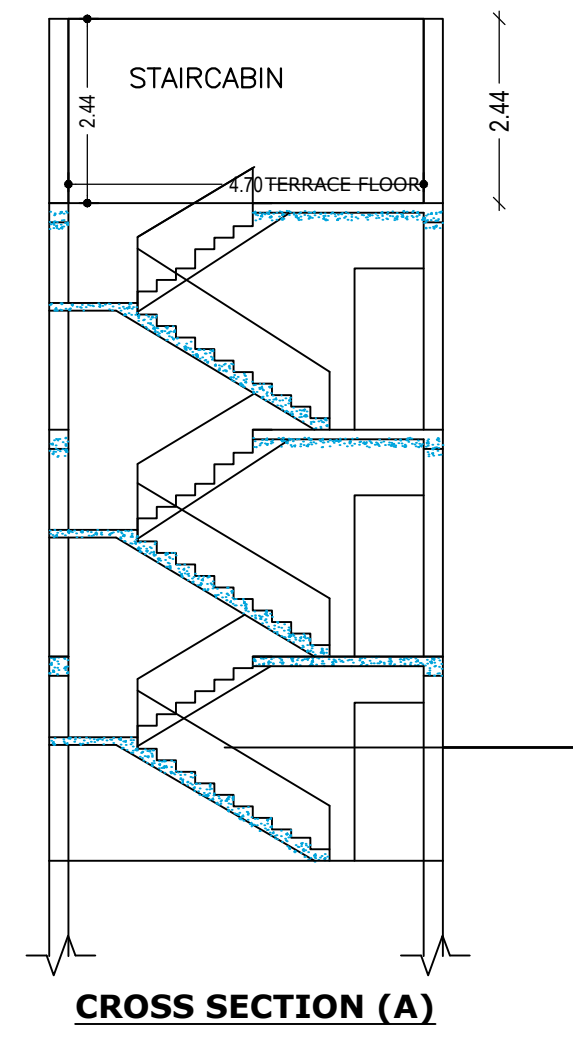

CROSS SECTION (A)

CROSS SECTION (B)

FAR & Tenement Details (Table 4c-1)

Building	No. of Same Bldg	Total Built Up Area (Sq.mt.)	Deductions (Area in Sq.mt.)		Proposed FAR Area (Sq.mt.)	Total FAR Area (Sq.mt.)	Total Consumed Additional FAR Area (Sq.mt.)	Trmnt (No.)
			Parking	Resi.				
A (RESICOMM)	1	228.87	58.70	0.00	152.58	152.58	152.58	01
<b>Grand Total :</b>	<b>1</b>	<b>228.87</b>	<b>58.70</b>	<b>0.00</b>	<b>152.58</b>	<b>152.58</b>	<b>152.58</b>	<b>01</b>

Proposal Basic Information

Proposal File No.	MNNP/EP/0177/W/17/2023
Owner Name	Shobha Ojha
Khata No	491
Plot No	1598
Village Name	Redma
Use	Residential
SubUse	Bungalow/ Dwelling / Non Apartment

AREA STATEMENT	VERSION NO. : 1.0.66
MEDININAGAR MUNICIPAL CORPORATION	VERSION DATE: 16/10/2020

Region: JHARKHAND URBAN LOCAL BODIES	Plot Use: Residential
District: PALAMU	Plot SubUse: Bungalow/ Dwelling / Non Apartment
Authority: MEDININAGAR MUNICIPAL CORPORATION	PlotNearbyReligiousStructure: NA
Inward No: MNNP/EP/0177/W/17/2023	Plot/SubPlot No: 1598
Application Type: General Proposal	North: -
Project Type: Building Permission	South: -
Nature of Development: New	East: -
Location of Development Area: Old Area	West: -

AREA DETAILS:		SQ.MT.
AREA OF PLOT (Minimum)	(A)	151.81
Deduction for NetPlot Area		
Surrender Free of Cost		18.91
Total		18.91
NET AREA OF PLOT(Gross Plot Area - Deduction from Gross Plot area)	(A-Deductions)	132.90
Deduction for Balance Plot Area(from Gross Plot Area)		
Surrender Free of Cost		18.91
Common Plot		18.83
Total		37.74
BALANCE AREA OF PLOT(Net Plot Area - Recreational/Amenity space)	(A-Deductions)	114.07
PLOT AREA FOR COVERAGE(Net Plot Area)	(A-Deductions)	132.90
Plot Area for FAR (Net Plot Area + Road/Widening Area)	(A-Deductions)	151.81

COVERAGE CHECK	
Permissible Coverage area ( 70.00 % )	93.03
Proposed Coverage Area ( 57.40 % )	76.29
Total Prop. Coverage Area ( 57.4 % )	76.29
Balance coverage area ( 12.60 % )	16.74

FAR CHECK	
Perm. FAR Area ( 1.200 )	182.17
Total Perm. FAR area	182.17
Residential FAR	152.58
Proposed FAR Area	152.58
Total Proposed FAR Area	152.58
Consumed FAR (Factor)	1.01
Balance FAR Area	29.59

BUILT UP AREA CHECK		228.87
ARCHITECT (Regd)	RANJIT KUMAR	
ENGINEER (Regd)		
SUPERVISOR (Regd)		
OWNER (Regd)	Shobha Ojha	
DEVELOPMENT AUTHORITY	LOCAL BODY	

COLOR INDEX	
PLOT BOUNDARY	[Red Line]
ABUTTING ROAD	[Green Line]
PROPOSED CONSTRUCTION	[Yellow Line]
COMMON PLOT	[Blue Line]
ROAD WIDENING AREA	[Orange Line]
EXISTING (To be retained)	[Grey Line]
EXISTING (To be demolished)	[Black Line]

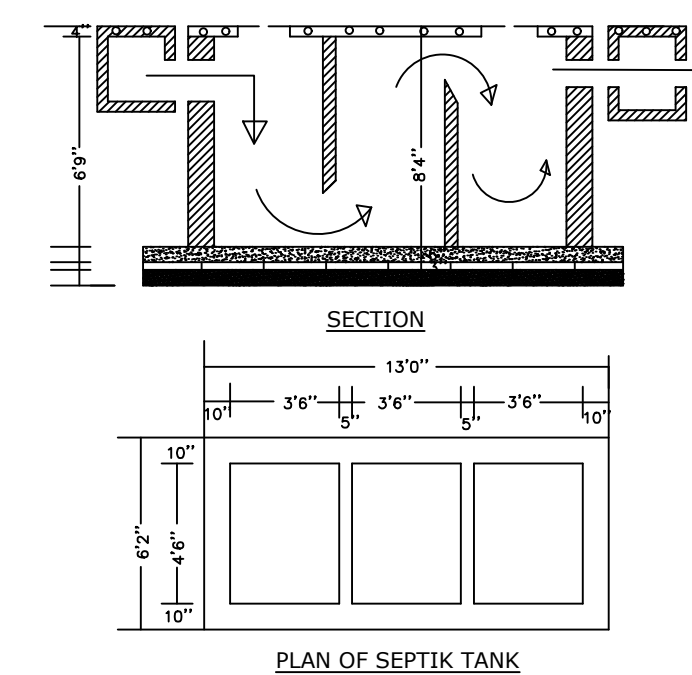
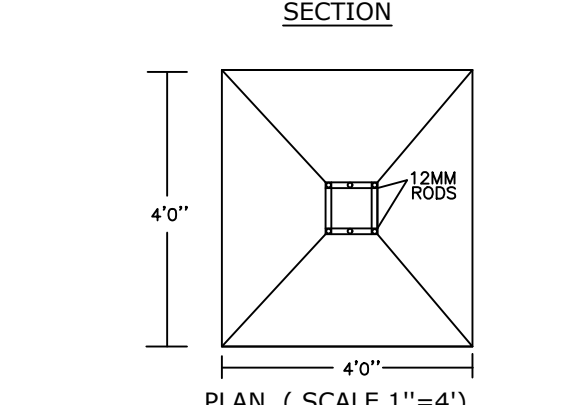
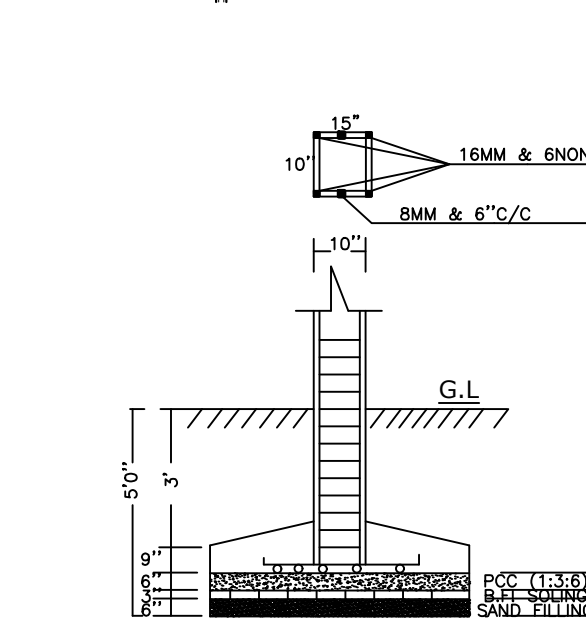
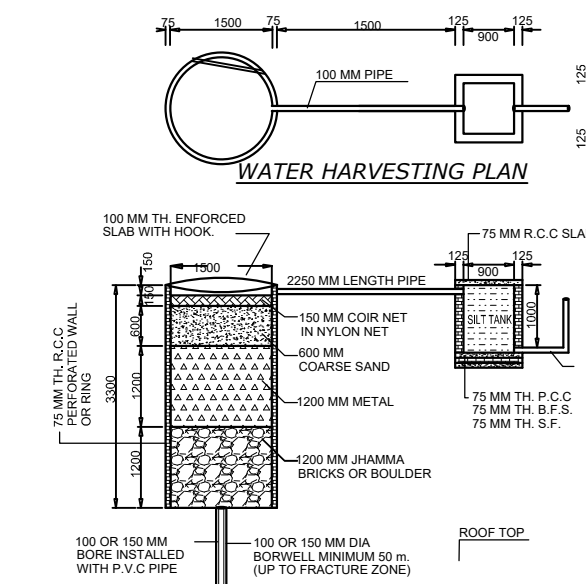

PLAN OF SEPTIC TANK

Buildingwise Floor FAR Details

Floor Name	Building Name A (RESICOMM)		Total	
	Proposed Built Up Area (Sq.mt.)	Proposed FAR Area (Sq.mt.)	Total Proposed Built Up Area (Sq.mt.)	Total FAR Area (Sq.mt.)
Basement Floor	76.29	0.00	76.29	0.00
Ground Floor	76.29	76.29	76.29	76.29
First Floor	76.29	76.29	76.29	76.29
Terrace Floor	0.00	0.00	0.00	0.00
<b>Total :</b>	<b>228.87</b>	<b>152.58</b>	<b>228.87</b>	<b>152.58</b>

Building USE/SUBUSE Details

Building Name	Building Use	Building SubUse	Building Structure
A (RESICOMM)	Residential	Bungalow/ Dwelling / Non Apartment	Non-Highrise

LTP NAME AND SIGNATURE	STRUCTURAL ENG'S NAME AND SIGNATURE	BUILDER NAME AND SIGNATURE	DIGITAL SIGNATURE
RANJIT KUMAR MNNP/ENG/0001/2016			