

Project Title :NIRMALA DEVI

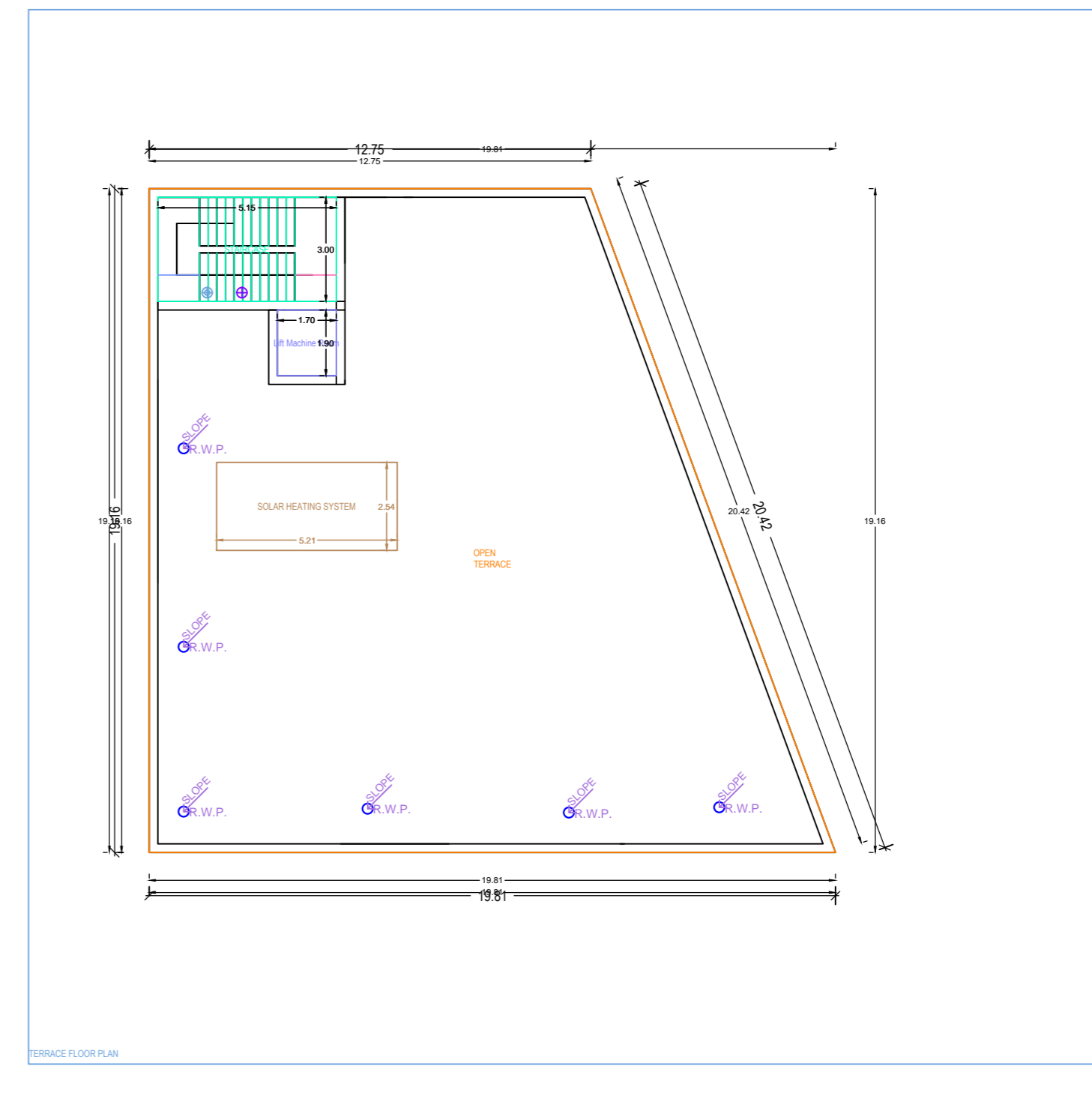
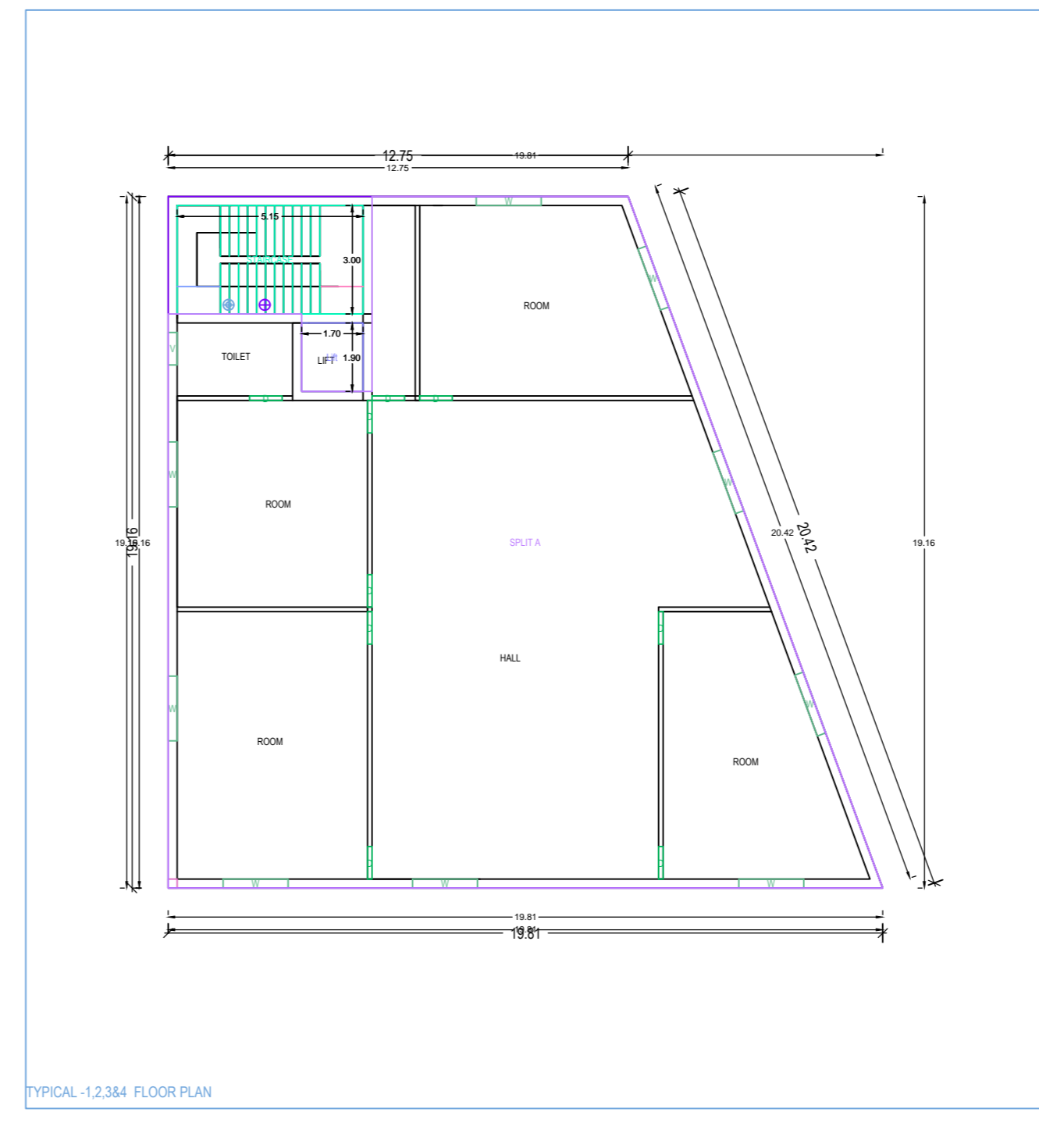
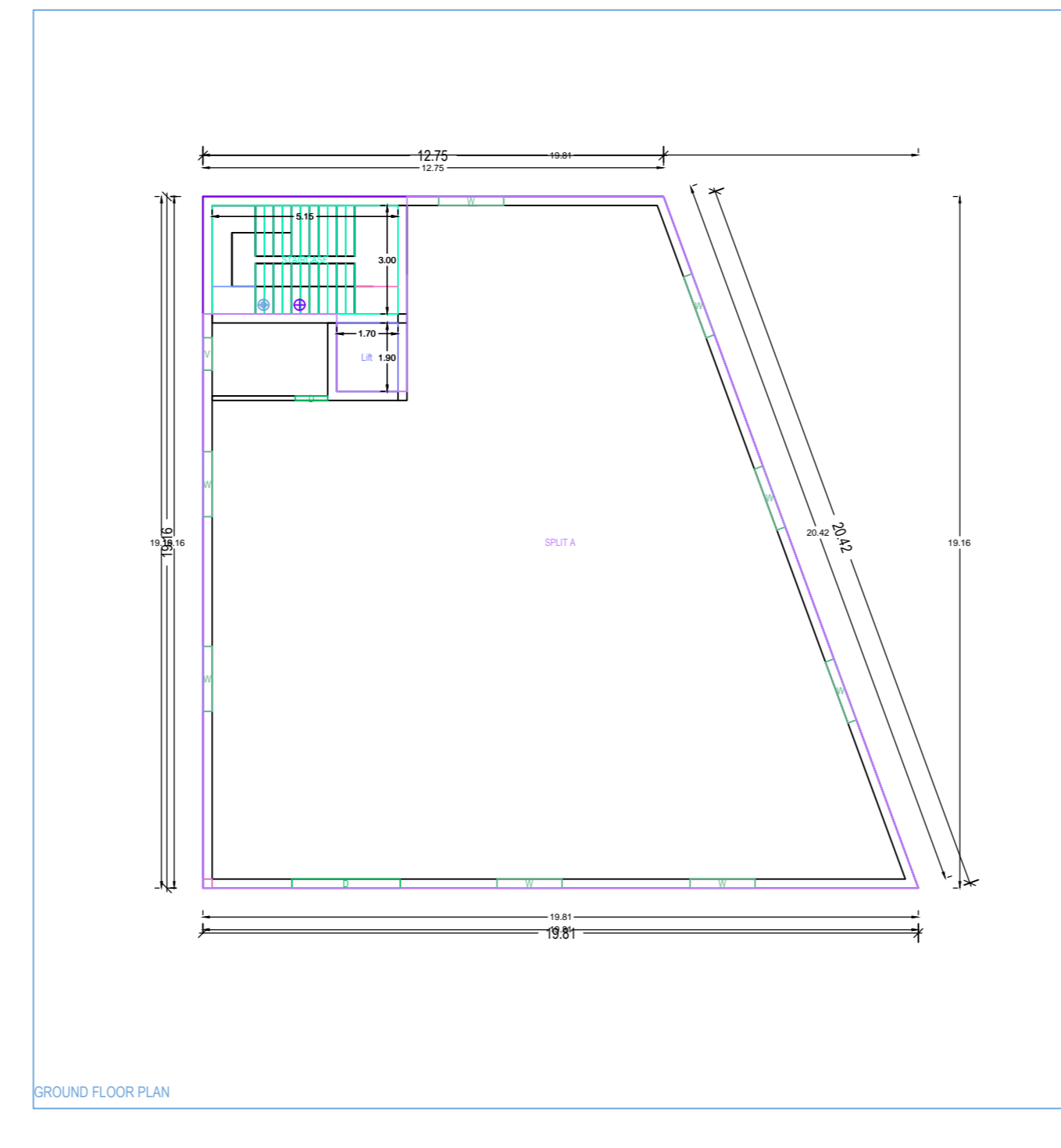
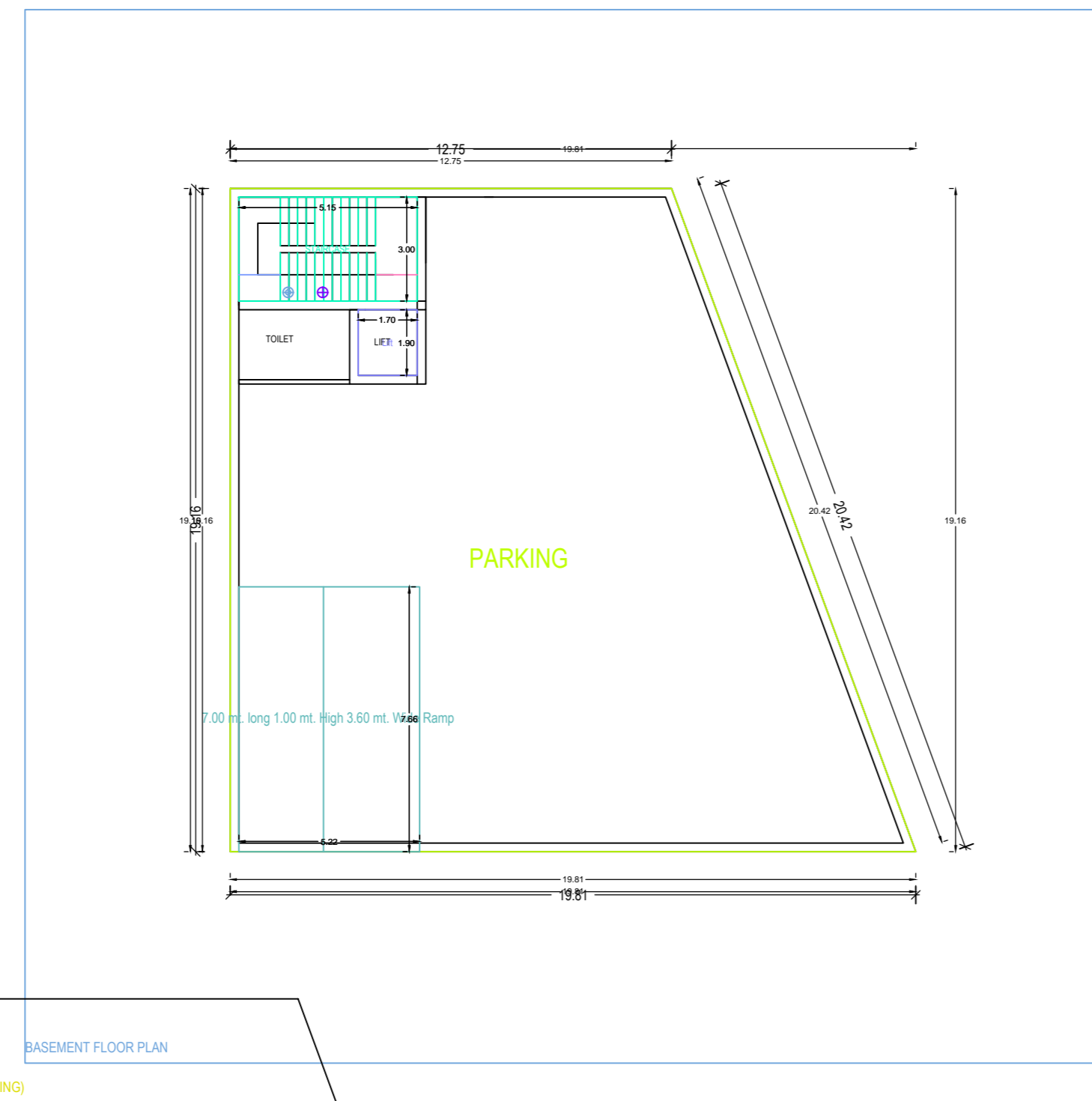
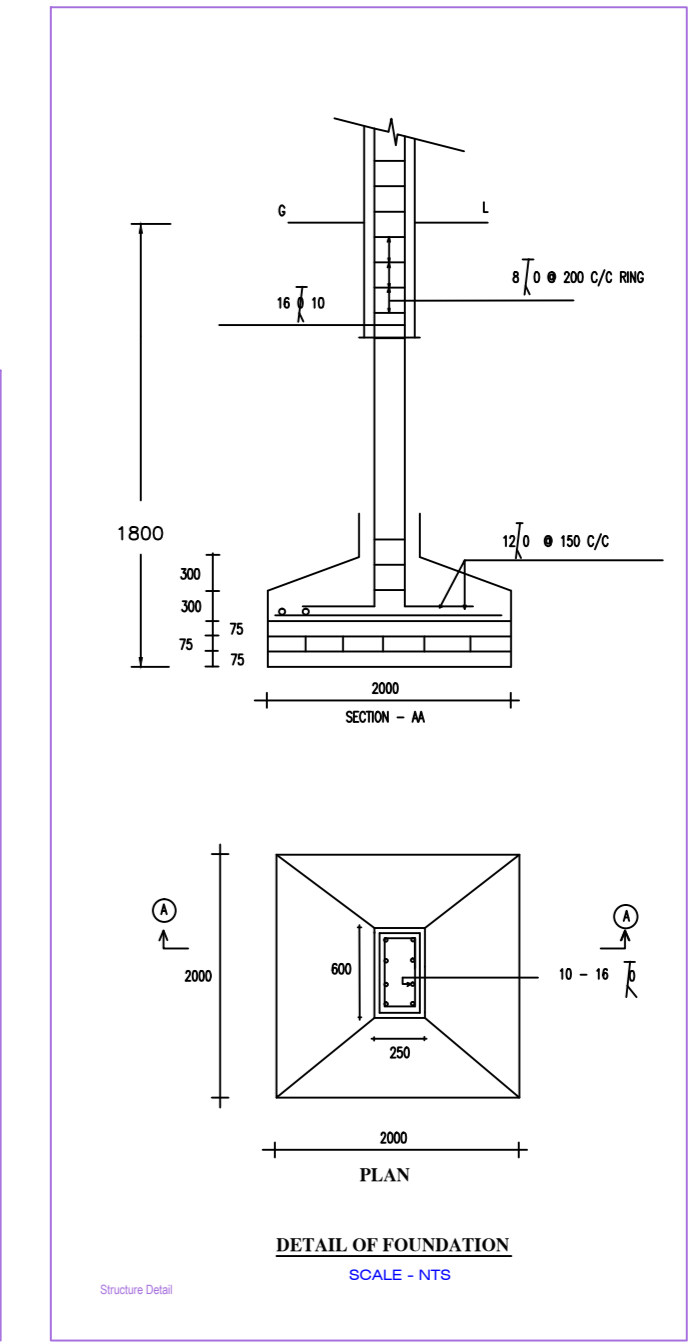
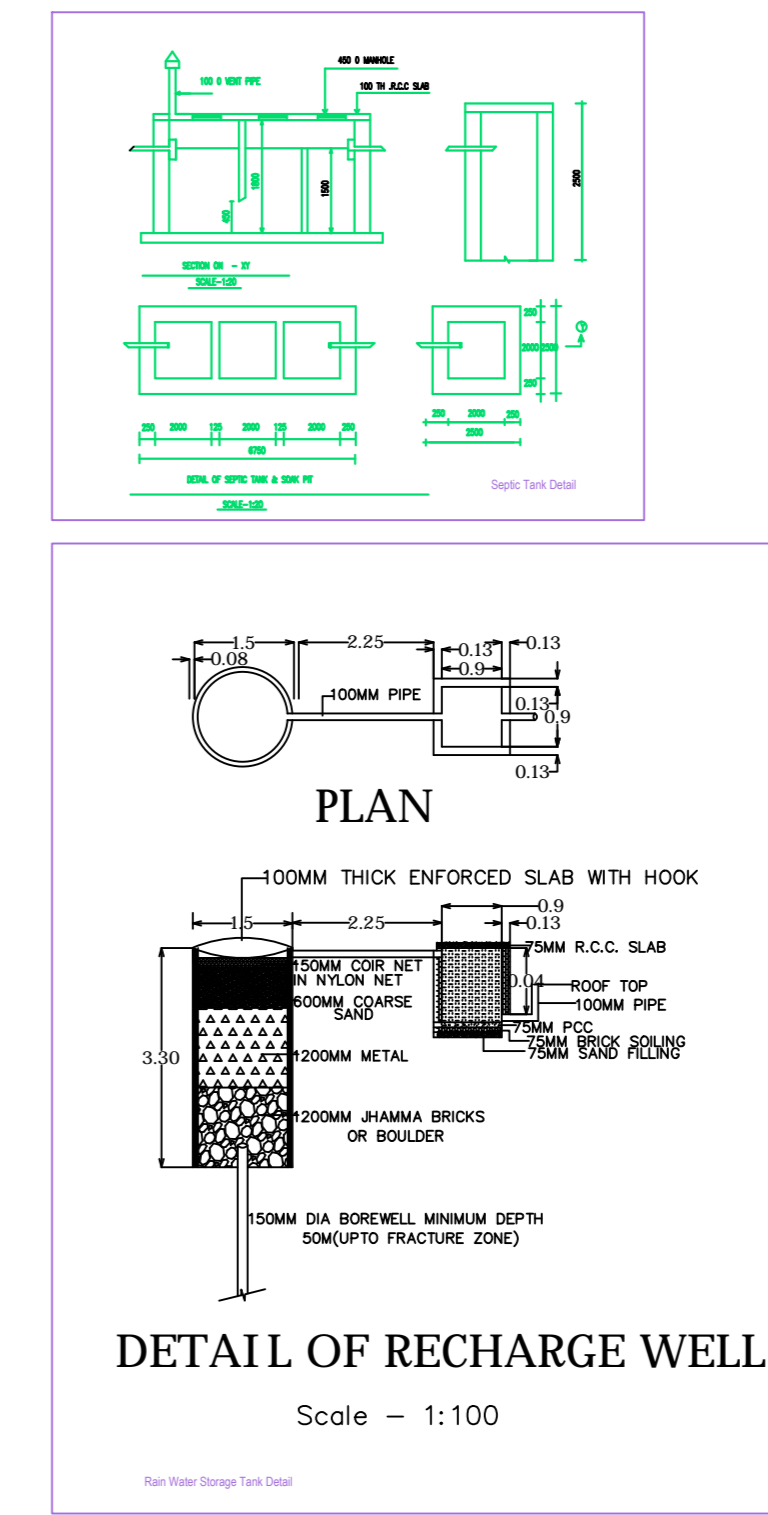
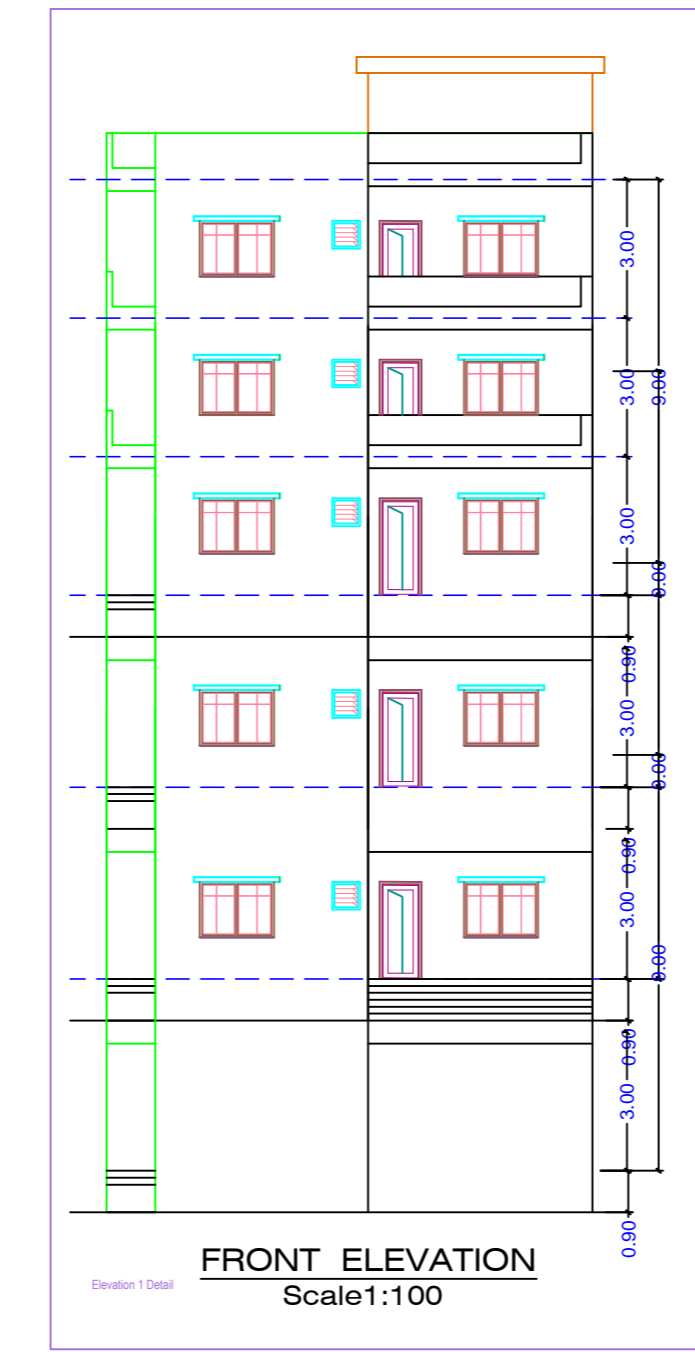
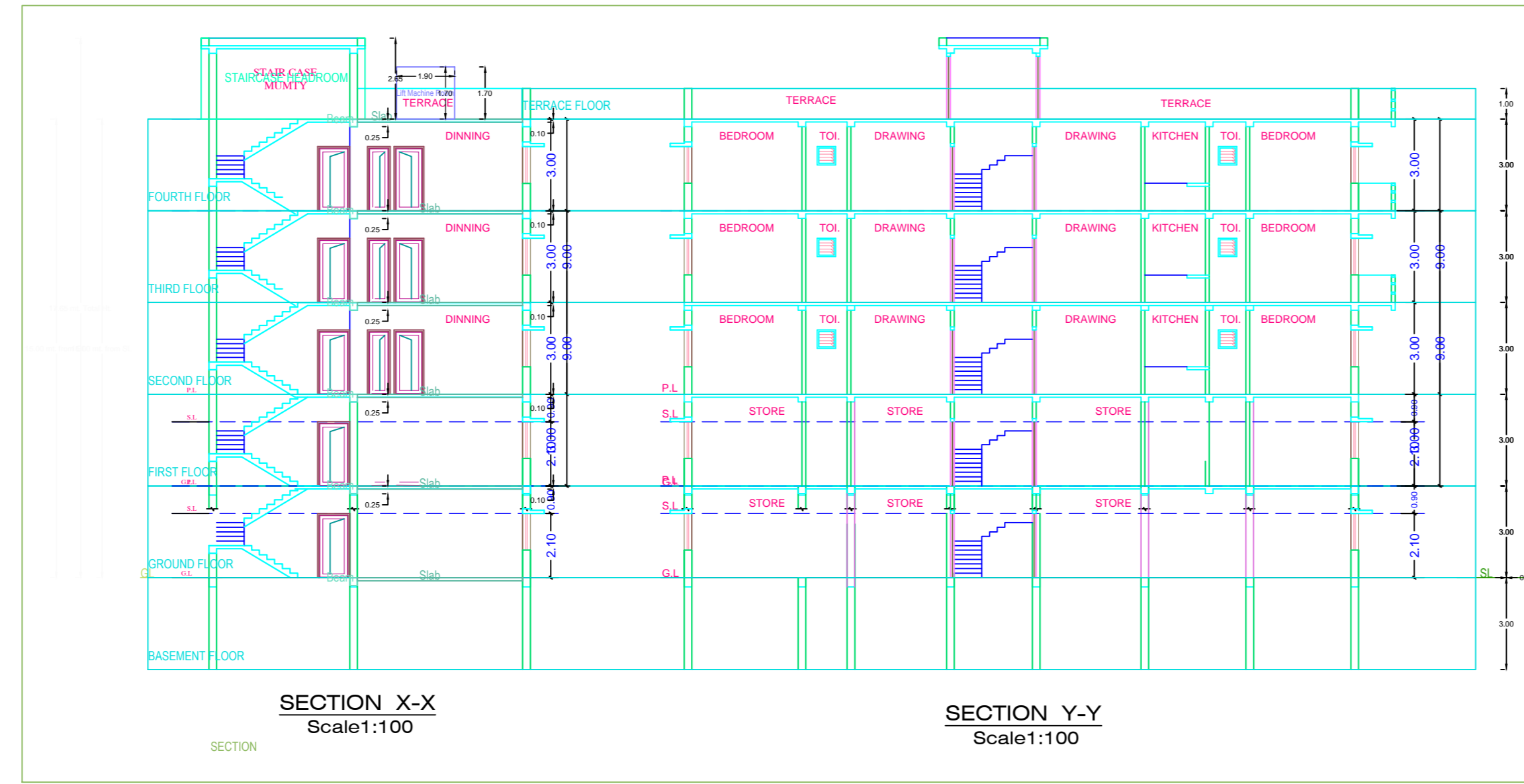
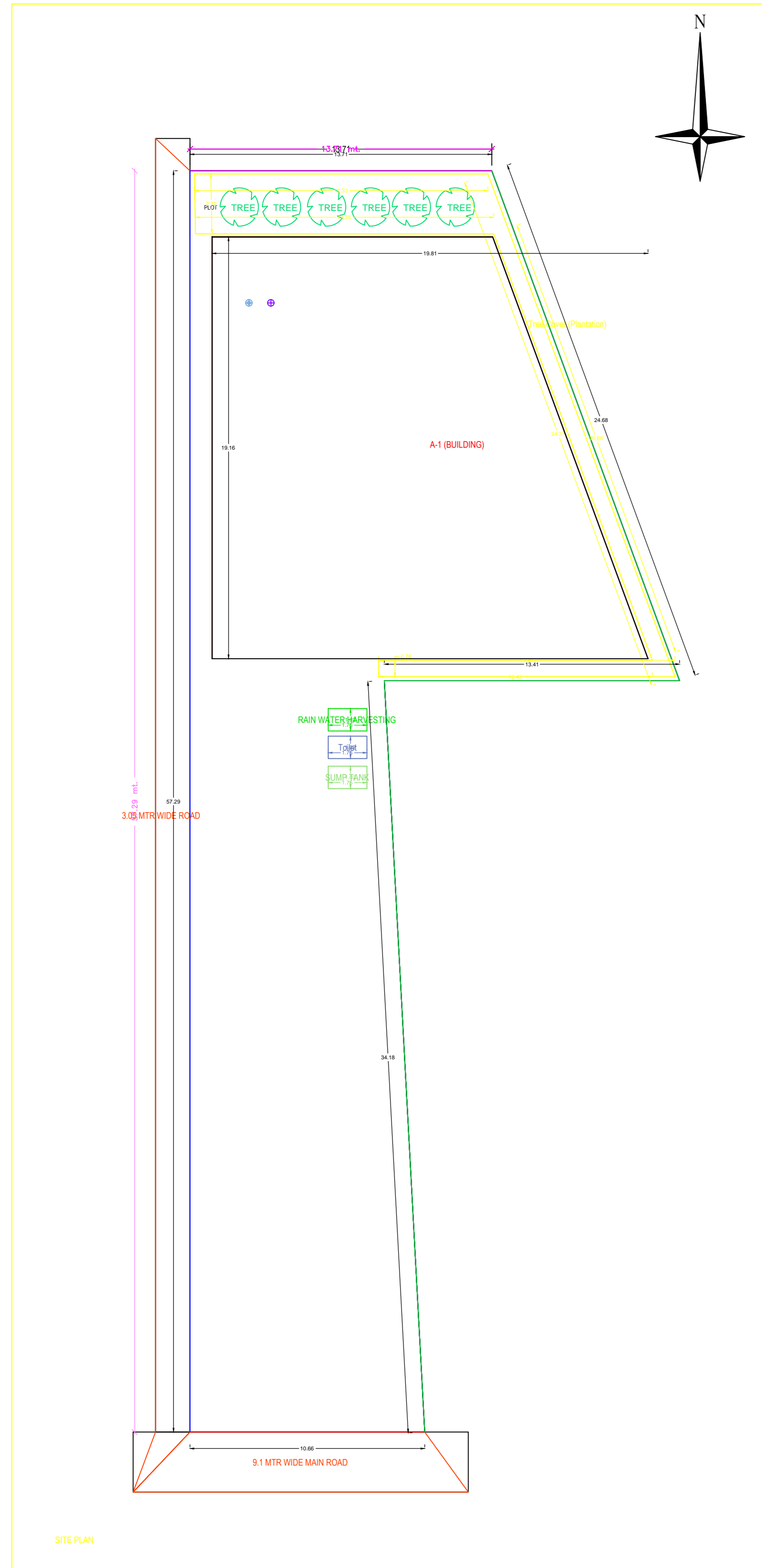

Building A (BALCONY)

Item Name	Total Area (sq.m)	Volume (cu.m)	Weight (kN)	Unit Price (Rs/m ²)	Total Cost (Rs)
Concrete	14.00	1.00	14.00	1400	19600
Steel	14.00	0.50	14.00	1400	19600
Formwork	14.00	0.00	14.00	1400	19600
Paint	14.00	0.00	14.00	1400	19600
Labour	14.00	0.00	14.00	1400	19600
Other	14.00	0.00	14.00	1400	19600
Total	56.00	1.50	56.00	1400	78400

SCHEDULE OF JOINTERY:

Item Name	Unit	Quantity	Unit Price (Rs)	Total Cost (Rs)
Jointery	m ²	14.00	1400	19600
Labour	m ²	14.00	1400	19600
Other	m ²	14.00	1400	19600
Total	m²	42.00	1400	58800

UNIT PRICE Table for Building A (BUILDING)

FLOOR	Name	UNIT PRICE	UNIT PRICE	UNIT PRICE	No. of Columns	No. of Beams
GROUND	UNIT A	1400	1400	1400	2	1
1ST	UNIT A	1400	1400	1400	2	1
2ND	UNIT A	1400	1400	1400	2	1
3RD	UNIT A	1400	1400	1400	2	1
4TH	UNIT A	1400	1400	1400	2	1
Total	UNIT A	5600	5600	5600	10	5

DEPARTMENT TECHNICAL DRAWING

PROJECT DATA

Project Name	NIRMALA DEVI
Client Name	...
Location	...
Scale	1:100
Author	...
Checked	...
Date	...

REVISIONS

No.	Description	Date
1
2

COLOR INDEX

Red	...
Green	...
Blue	...
Yellow	...

PARKING CALCULATION

Area	...
Capacity	...

MARGIN DETAIL

Item	Quantity	Unit Price	Total Cost
...

REVISIONS

No.	Description	Date
1