

SITE PLAN

FAR & Tenement Details (Table 4c-1)

Building	No. of Same Bldg	Total Built Up Area (Sq.mt.)	Proposed FAR Area (Sq.mt.)	Total FAR Area (Sq.mt.)	Total Consumed Additional FAR Area (Sq.mt.)	Tnmt (No.)
A (BUILDING)	1	239.79	239.79	239.79	239.79	01
Grand Total :	1	239.79	239.79	239.79	239.79	01

Proposal Basic Information

Proposal File No.	MNNP/BP/0111/W06/2024
Owner Name	Pradeep Kumar
Khata No	123
Plot No	1888
Village Name	Baralota
Use	Residential
SubUse	Bungalow/ Dwelling / Non Apartment

AREA STATEMENT	VERSION NO. : 1.0.70		
MEDININAGAR MUNICIPAL CORPORATION	VERSION DATE: 16/10/2020		
PROJECT DETAIL:			
Region: JHARKHAND URBAN LOCAL BODIES	Plot Use: Residential		
District: PALAMU	Plot SubUse: Bungalow/ Dwelling / Non Apartment		
Authority: MEDININAGAR MUNICIPAL CORPORATION	PlotNearbyReligiousStructure: NA		
Inward No: MNNP/BP/0111/W06/2024	Plot/SubPlot No: 1888		
Application Type: General Proposal	North: -		
Project Type: Building Permission	South: -		
Nature of Development: New	East: -		
Location of Development Area: Old Area	West: -		
AREA DETAILS:			
AREA OF PLOT (Minimum)	(A)	SQ.MT.	161.50
Deduction for NetPlot Area			
Surrender Free of Cost			11.15
Total			11.15
NET AREA OF PLOT(Gross Plot Area - Deduction from Gross Plot area)	(A-Deductions)		150.35
Deduction for Balance Plot Area(from Gross Plot Area)			
Surrender Free of Cost			11.15
Common Plot			14.86
Total			26.01
BALANCE AREA OF PLOT(Net Plot Area - Recreational/Amenity space)	(A-Deductions)		135.50
PLOT AREA FOR COVERAGE(Net Plot Area)	(A-Deductions)		150.35
Plot Area for FAR (Net Plot Area + Road/Widening Area)	(A-Deductions)		161.50
COVERAGE CHECK			
Permissible Coverage area (70.00 %)			105.25
Proposed Coverage Area (53.16 %)			79.93
Total Prop. Coverage Area (53.16 %)			79.93
Balance coverage area (16.84 %)			25.32
FAR CHECK			
Perm. FAR Area (1.500)			242.25
Total Perm. FAR area			242.25
Residential FAR			239.78
Proposed FAR Area			239.78
Total Proposed FAR Area			239.78
Consumed FAR (Factor)			1.48
Balance FAR Area			2.47
BUILT UP AREA CHECK			
Total Proposed BuiltUp Area			239.79
ARCHITECT (Regd)		PANKAJ KUMAR SINGH	
ENGINEER (Regd)			
SUPERVISOR (Regd)			
OWNER (Regd)		Pradeep Kumar	
DEVELOPMENT AUTHORITY			LOCAL BODY

COLOR INDEX	
PLOT BOUNDARY	Black
ABUTTING ROAD	Green
PROPOSED CONSTRUCTION	Red
COMMON PLOT	Yellow
ROAD WIDENING AREA	Blue
EXISTING (To be retained)	Light Blue
EXISTING (To be demolished)	Light Yellow

Buildingwise Floor FAR Details

Floor Name	Building Name		Total	
	Proposed Built Up Area (Sq.mt.)	Proposed FAR Area (Sq.mt.)	Total Proposed Built Up Area (Sq.mt.)	Total FAR Area (Sq.mt.)
Ground Floor	79.93	79.93	79.93	79.93
First Floor	79.93	79.93	79.93	79.93
Second Floor	79.93	79.93	79.93	79.93
Terrace Floor	0.00	0.00	0.00	0.00
Total :	239.79	239.79	239.79	239.79

Building USE/SUBUSE Details

Building Name	Building Use	Building SubUse	Building Structure
A (BUILDING)	Residential	Bungalow/ Dwelling / Non Apartment	Non-Highrise

LTP NAME AND SIGNATURE	STRUCTURAL ENG'S NAME AND SIGNATURE	BUILDER NAME AND SIGNATURE	DIGITAL SIGNATURE
PANKAJ KUMAR SINGH MNNP/ENG/0006/2019			

Proposal Basic Information	
Proposal File No.	MNNP/BP/0111/W06/2024
Owner Name	Pradeep Kumar
Khata No	123
Plot No	1888
Village Name	Baralota
Use	Residential
SubUse	Bungalow/ Dwelling / Non Apartment

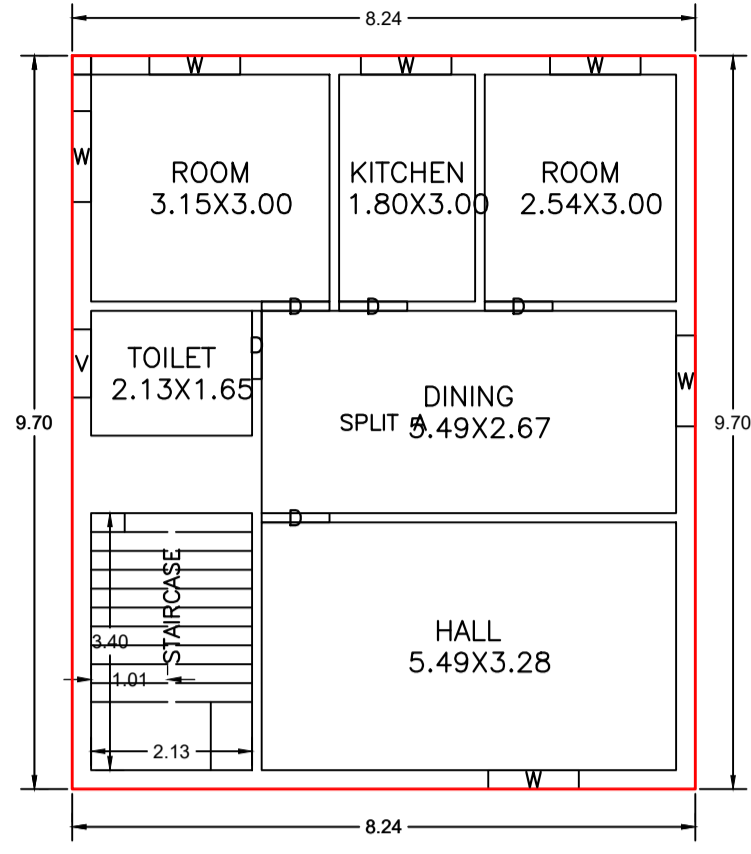

GROUND FLOOR PLAN (Proposed) (SCALE 1:100)

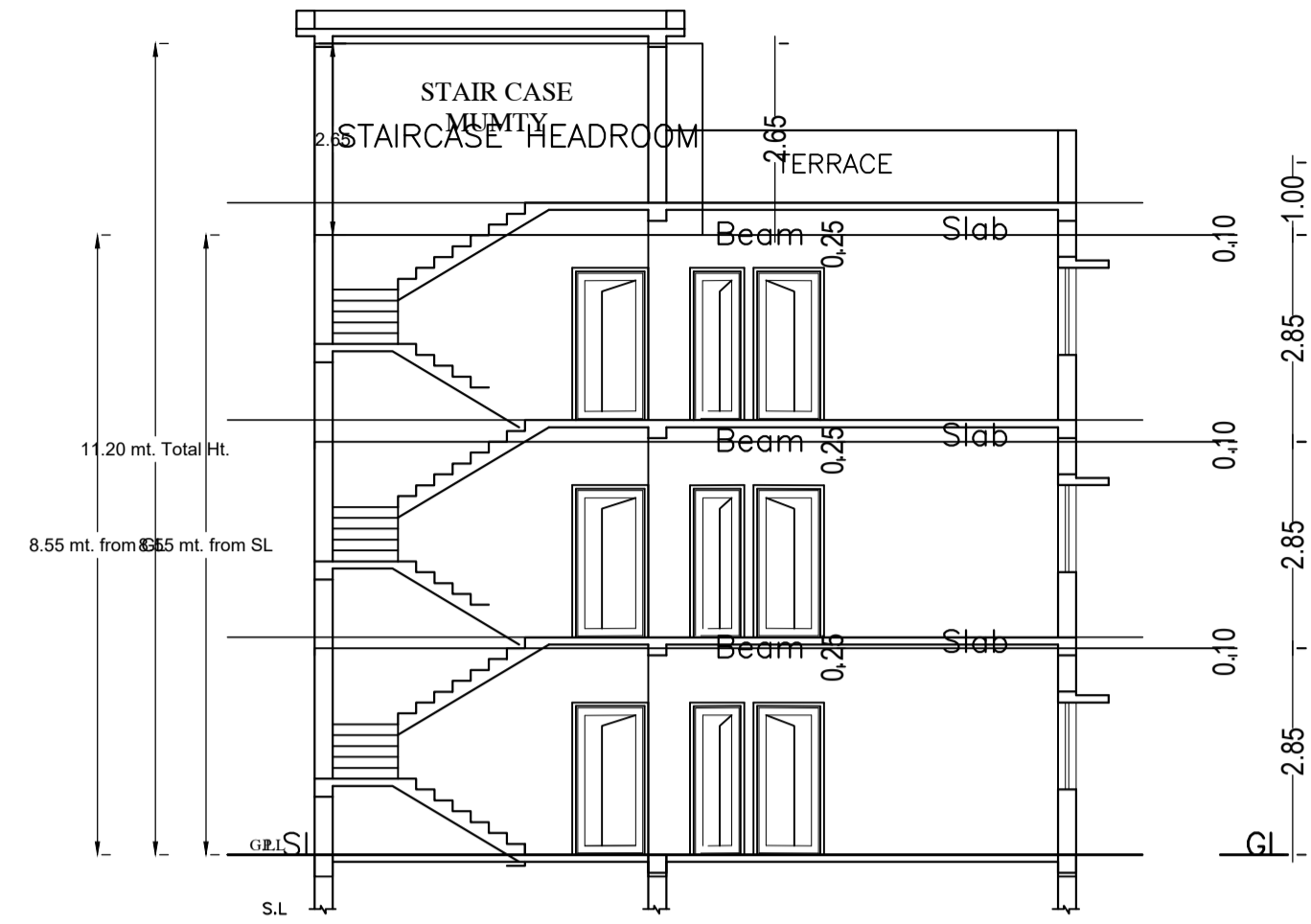

SECTION X-X Scale 1:100

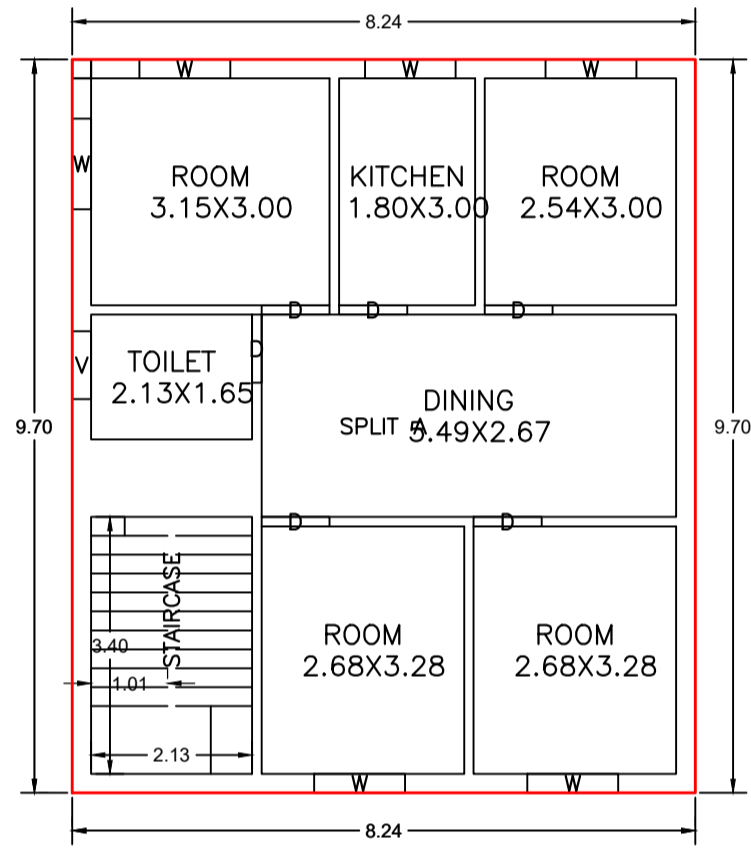

TYPICAL -1&2 FLOOR PLAN (Proposed) (SCALE 1:100)

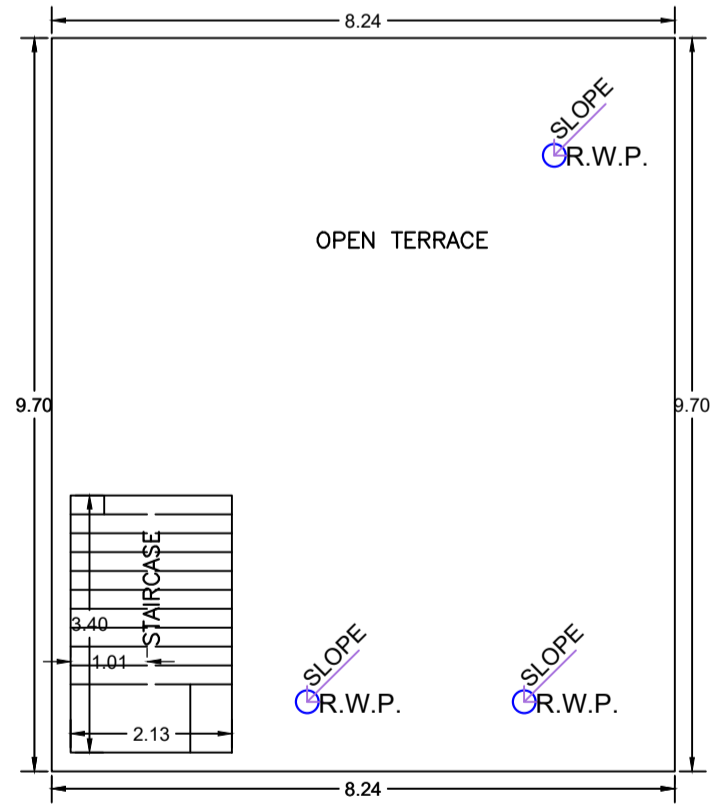

TERRACE FLOOR PLAN (SCALE 1:100)



FRONT ELEVATION Scale 1:100



RIGHT SIDE ELEVATION Scale 1:100

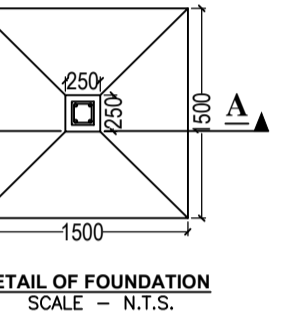
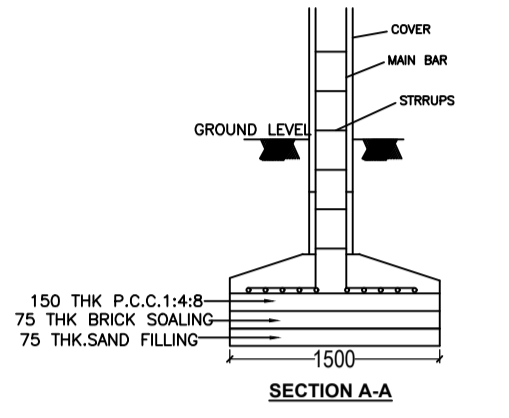

DETAIL OF FOUNDATION SCALE - N.T.S.

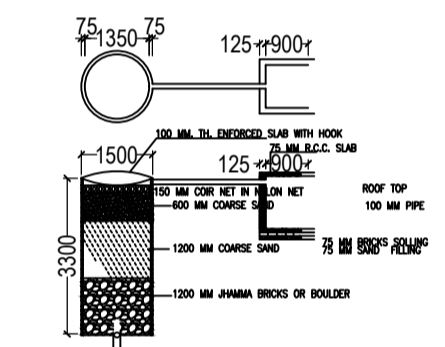

DETAIL OF GROUND WATER RECHARGING PIT WITH SILT TANK SCALE - N.T.S.

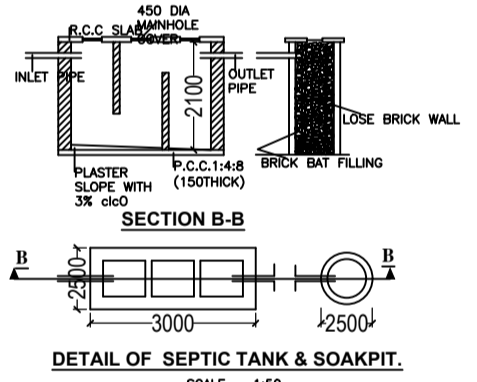

DETAIL OF SEPTIC TANK & SOAKPIT SCALE - 1:50

Building :A (BUILDING)

Floor Name	Total Built Up Area (Sq.mt.)	Proposed FAR Area (Sq.mt.) Resi.	Total FAR Area (Sq.mt.)	Total Consumed Additional FAR Area (Sq.mt.)	Tnmt (No.)
Ground Floor	79.93	79.93	79.93	79.93	01
First Floor	79.93	79.93	79.93	79.93	00
Second Floor	79.93	79.93	79.93	79.93	00
Terrace Floor	0.00	0.00	0.00	0.00	00
Total :	239.79	239.79	239.79	239.79	01
Total Number of Same Buildings	1				
Total :	239.79	239.79	239.79	239.79	01

SCHEDULE OF DOOR:

BUILDING NAME	NAME	LENGTH	HEIGHT	NOS
A (BUILDING)	D	0.90	2.10	17

SCHEDULE OF WINDOW/VENTILATION:

BUILDING NAME	NAME	LENGTH	HEIGHT	NOS
A (BUILDING)	V	0.90	0.60	03
A (BUILDING)	W	1.20	1.20	18

UnitBUA Table for Building :A (BUILDING)

FLOOR	Name	UnitBUA Type	UnitBUA Area	Carpet Area	No. of Rooms	No. of Tenement
GROUND FLOOR PLAN	SPLIT A	FLAT	213.72	213.54	6	1
TYPICAL-1&2 FLOOR PLAN	SPLIT A	FLAT	0.00	0.00	7	0
Total:	-	-	213.72	213.54	20	1

LTP NAME AND SIGNATURE	STRUCTURAL ENG'S NAME AND SIGNATURE	BUILDER NAME AND SIGNATURE	DIGITAL SIGNATURE
PANKAJ KUMAR SINGH MNNP/ENG/0006/2019			