

SITE PLAN

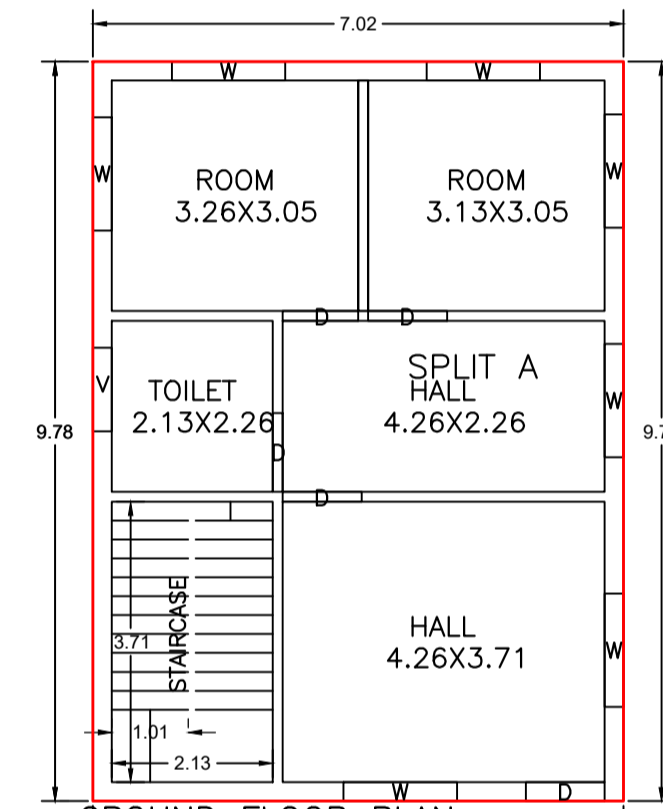

GROUND FLOOR PLAN (Proposed) (SCALE 1:100)

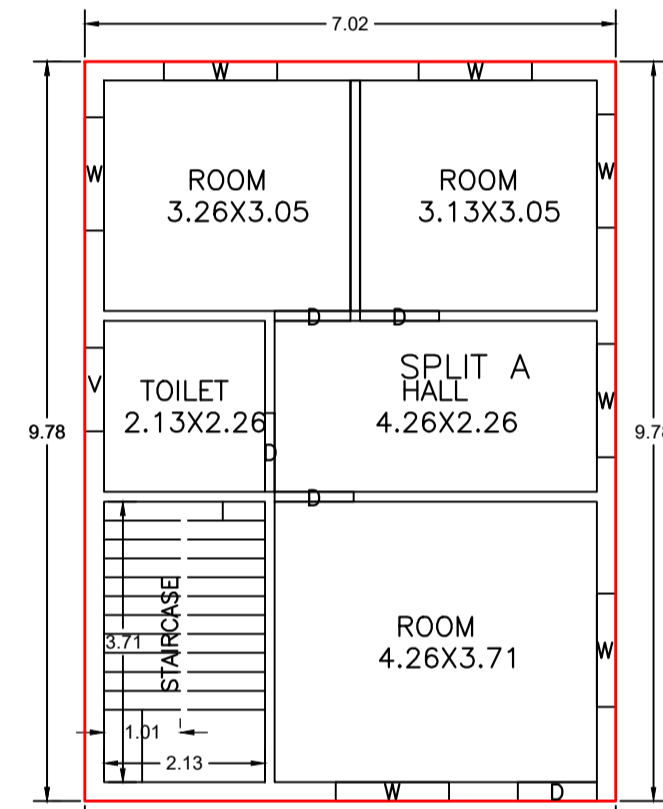

FIRST FLOOR PLAN (Proposed) (SCALE 1:100)

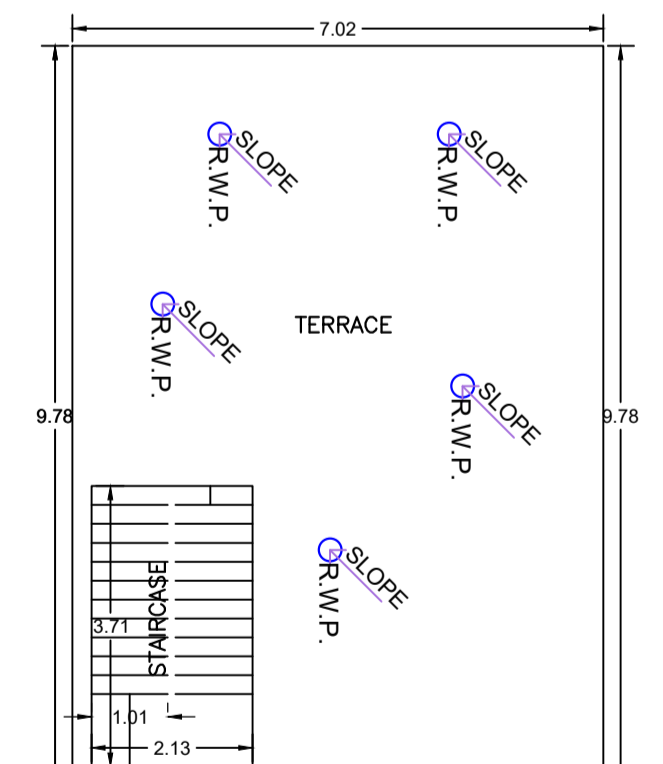

TERRACE FLOOR PLAN (Proposed) (SCALE 1:100)

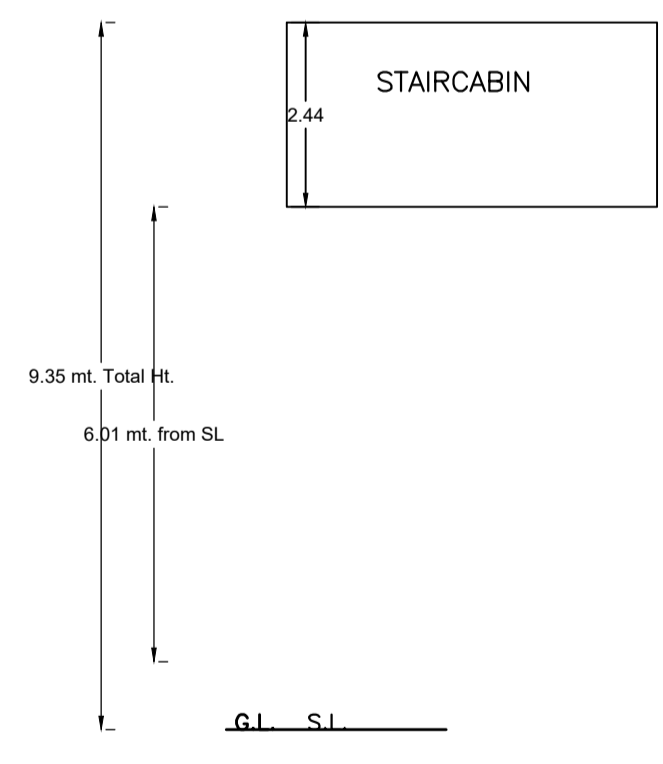

Building :A (RESIDENTIAL)

Floor Name	Total Built Up Area (Sq.mt.)	Proposed FAR Area (Sq.mt.) Resi.	Total FAR Area (Sq.mt.)	Total Consumed Additional FAR Area (Sq.mt.)	Tnmt (No.)
Ground Floor	68.66	68.66	68.66	68.66	01
First Floor	68.66	68.66	68.66	68.66	00
Terrace Floor	0.00	0.00	0.00	0.00	00
Total :	137.32	137.32	137.32	137.32	01
Total Number of Same Buildings :	1				
Total :	137.32	137.32	137.32	137.32	01

SCHEDULE OF DOOR:

BUILDING NAME	NAME	LENGTH	HEIGHT	NOS
A (RESIDENTIAL)	D	1.00	2.10	02
A (RESIDENTIAL)	D	1.04	2.10	08

SCHEDULE OF WINDOW/VENTILATION:

BUILDING NAME	NAME	LENGTH	HEIGHT	NOS
A (RESIDENTIAL)	V	1.11	1.20	02
A (RESIDENTIAL)	W	1.50	1.20	14

UnitBUA Table for Building :A (RESIDENTIAL)

FLOOR	Name	UnitBUA Type	UnitBUA Area	Carpet Area	No. of Rooms	No. of Tenement
GROUND FLOOR PLAN	SPLIT A	FLAT	118.48	117.69	5	1
FIRST FLOOR PLAN	SPLIT A	FLAT	0.00	0.00	5	0
Total:	-	-	118.48	117.69	10	1

FAR & Tenement Details (Table 4c-1)

Building	No. of Same Bldg	Total Built Up Area (Sq.mt.)	Proposed FAR Area (Sq.mt.) Resi.	Total FAR Area (Sq.mt.)	Total Consumed Additional FAR Area (Sq.mt.)	Tnmt (No.)
A (RESIDENTIAL)	1	137.32	137.32	137.32	137.32	01
Grand Total :	1	137.32	137.32	137.32	137.32	01

Proposal Basic Information

Proposal File No.	MNNP/BP/0197/W03/2024
Owner Name	MAMTA DEVI
Khata No	72
Plot No	160
Village Name	Sudma Bariya
Use	Residential
SubUse	Bungalow/ Dwelling / Non Apartment

AREA STATEMENT		VERSION NO. : 1.070
MEDINAGAR MUNICIPAL CORPORATION		VERSION DATE: 18/10/2020
PROJECT DETAIL:		
Region : JHARKHAND URBAN LOCAL BODIES	Plot Use: Residential	
District: PALAMU	Plot SubUse: Bungalow/ Dwelling / Non Apartment	
Authority: MEDINAGAR MUNICIPAL CORPORATION	PlotNearbyReligiousStructure: NA	
Inward No: MNNP/BP/0197/W03/2024	Plot/SubPlot No: 160	
Application Type: General Proposal	North: -	
Project Type: Building Permission	South: -	
Nature of Development: New	East: -	
Location of Development Area: Old	West: -	
AREA DETAILS:		
AREA OF PLOT (Minimum)	(A)	SQ.MT. 121.44
Deduction for NetPlot Area		
Surrender Free of Cost		12.47
Total		12.47
NET AREA OF PLOT(Gross Plot Area - Deduction from Gross Plot area)	(A-Deductions)	108.97
Deduction for Balance Plot Area(from Gross Plot Area)		
Surrender Free of Cost		12.47
Common Plot		11.88
Total		24.35
BALANCE AREA OF PLOT(Net Plot Area - Recreational/Amenity space)	(A-Deductions)	97.09
PLOT AREA FOR COVERAGE(Net Plot Area)	(A-Deductions)	108.97
Plot Area for FAR (Net Plot Area + RoadWidening Area)	(A-Deductions)	121.44
COVERAGE CHECK		
Permissible Coverage area (70.00 %)		76.28
Proposed Coverage Area (63.01 %)		68.66
Total Prop. Coverage Area (63.01 %)		68.66
Balance coverage area (6.99 %)		7.62
FAR CHECK		
Perm. FAR Area (1200)		145.73
Total Perm. FAR area		145.73
Residential FAR		137.33
Proposed FAR Area		137.33
Total Proposed FAR Area		137.33
Consumed FAR (Factor)		1.13
Balance FAR Area		8.40
BUILT UP AREA CHECK		
Total Proposed BuiltUp Area		137.32
ARCHITECT (Regd)	Umesh Prasad	
ENGINEER (Regd)		
SUPERVISOR (Regd)		
OWNER (Regd)	MAMTA DEVI	
DEVELOPMENT AUTHORITY		LOCAL BODY

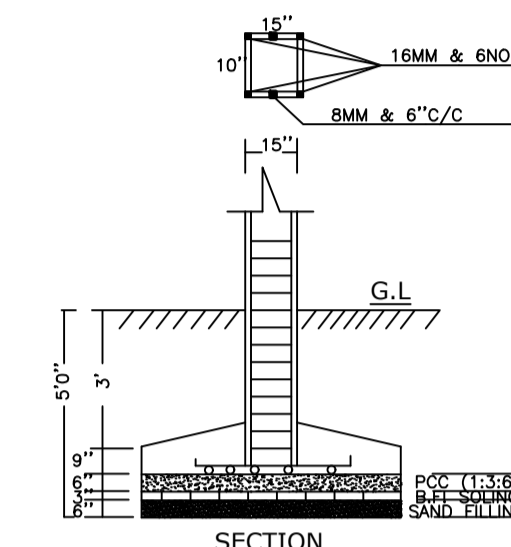

SECTION

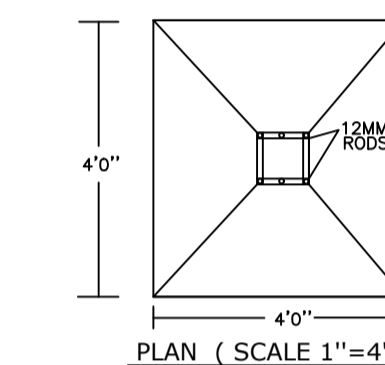

PLAN (SCALE 1"=4')

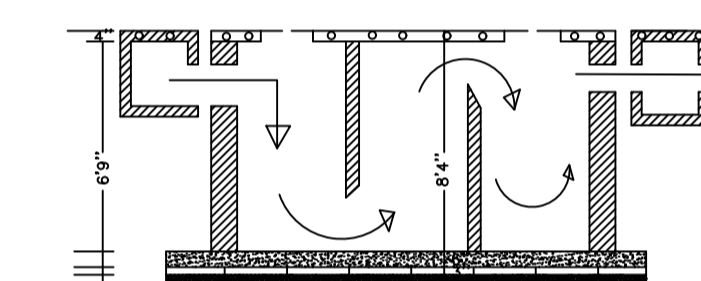

SECTION

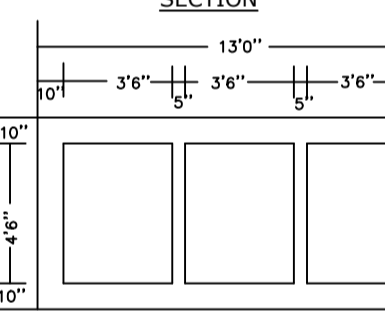

PLAN OF SEPTIC TANK

COLOR INDEX	
PLOT BOUNDARY	[Red Line]
ABUTTING ROAD	[Green Line]
PROPOSED CONSTRUCTION	[Yellow Line]
COMMON PLOT	[Blue Line]
ROAD WIDENING AREA	[Orange Line]
EXISTING (To be retained)	[Grey Line]
EXISTING (To be demolished)	[Black Line]

Buildingwise Floor FAR Details

Floor Name	Building Name A (RESIDENTIAL)		Total	
	Proposed Built Up Area (Sq.mt.)	Proposed FAR Area (Sq.mt.)	Total Proposed Built Up Area (Sq.mt.)	Total FAR Area (Sq.mt.)
Ground Floor	68.66	68.66	68.66	68.66
First Floor	68.66	68.66	68.66	68.66
Terrace Floor	0.00	0.00	0.00	0.00
Total :	137.32	137.32	137.32	137.32

Building USE/SUBUSE Details

Building Name	Building Use	Building SubUse	Building Structure
A (RESIDENTIAL)	Residential	Bungalow/ Dwelling / Non Apartment	Non-Highrise

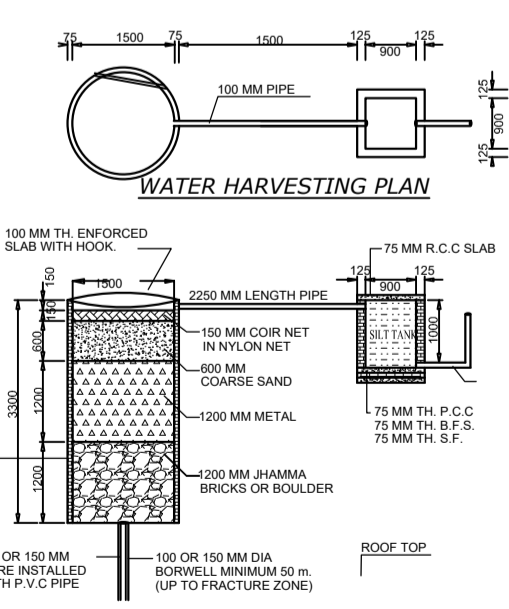

WATER HARVESTING PLAN

LTP NAME AND SIGNATURE	STRUCTURAL ENG'S NAME AND SIGNATURE	BUILDER NAME AND SIGNATURE	DIGITAL SIGNATURE
Umesh Prasad MNNP/ENG/0002/2024			