

SITE PLAN

Proposal Basic Information

Proposal File No.	MNNP/EP/0201/W08/2024
Owner Name	KANTI PANDEY
Khata No	163
Plot No	250,251
Village Name	Baralota
Use	Residential
SubUse	Bungalow/ Dwelling / Non Apartment

Building USE/SUBUSE Details

Building Name	Building Use	Building SubUse	Building Structure	Floor Name	Floor Use	Floor SubUse	FAR Name	FAR Use	FAR SubUse
A (RESIDENTIAL)	Residential	Bungalow/ Dwelling / Non Apartment	Non-Highrise	TERRACE FLOOR PLAN	Residential	Bungalow/ Dwelling / Non Apartment	-	-	-
				GROUND FLOOR PLAN	Residential	Bungalow/ Dwelling / Non Apartment	Residential FAR	Residential	Bungalow/ Dwelling / Non Apartment
				FIRST FLOOR PLAN	Residential	Bungalow/ Dwelling / Non Apartment	Residential FAR	Residential	Bungalow/ Dwelling / Non Apartment

AREA STATEMENT	VERSION NO.: 1.0.71		
MEDINAGAR MUNICIPAL CORPORATION	VERSION DATE: 16/10/2020		
PROJECT DETAIL:			
Region: JHARKHAND URBAN LOCAL BODIES	Plot Use: Residential		
District: PALAMU	Plot SubUse: Bungalow/ Dwelling / Non Apartment		
Authority: MEDINAGAR MUNICIPAL CORPORATION	Plot/Nearby/Religious/Structure: NA		
Inward No: MNNP/EP/0201/W08/2024	Plot/SubPlot No: 250,251		
Application Type: General Proposal	North: -		
Project Type: Building Permission	South: -		
Nature of Development: New	East: -		
Location of Development Area: New	West: -		
AREA DETAILS:			
AREA OF PLOT (Minimum)	(A)	SQ.MT.	425.07
Deduction for NetPlot Area			18.22
Surrender Free of Cost			18.22
Total			406.85
NET AREA OF PLOT(Gross Plot Area - Deduction from Gross Plot area)	(A-Deductions)		406.85
Deduction for Balance Plot Area(from Gross Plot Area)			
Surrender Free of Cost			18.22
Common Plot			51.84
Total			70.06
BALANCE AREA OF PLOT(Net Plot Area - Recreational/Amenity space)	(A-Deductions)		355.01
PLOT AREA FOR COVERAGE(Net Plot Area)	(A-Deductions)		406.85
Plot Area for FAR (Net Plot Area + RoadWidening Area)	(A-Deductions)		425.07
COVERAGE CHECK			
Permissible Coverage area (60.00 %)			244.11
Proposed Coverage Area (27.34 %)			111.24
Total Prop. Coverage Area (27.34 %)			111.24
Balance coverage area (32.66 %)			132.87
FAR CHECK			
Perm. FAR Area (1.500)			637.60
Total Perm. FAR area			637.60
Residential FAR			222.47
Proposed FAR Area			222.47
Total Proposed FAR Area			222.47
Consumed FAR (Factor)			0.52
Balance FAR Area			415.13
BUILT UP AREA CHECK			
Total Proposed BuiltUp Area			222.48
ARCHITECT (Regd)		Umesh Prasad	
ENGINEER (Regd)			
SUPERVISOR (Regd)			
OWNER (Regd)		KANTI PANDEY	
DEVELOPMENT AUTHORITY		LOCAL BODY	

COLOR INDEX

PLOT BOUNDARY	Black
ABUTTING ROAD	Green
PROPOSED CONSTRUCTION	Red
COMMON PLOT	Yellow
ROAD WIDENING AREA	Blue
EXISTING (To be retained)	Light Blue
EXISTING (To be demolished)	Light Yellow

Buildingwise Floor FAR Details

Floor Name	Building Name A (RESIDENTIAL)		Total	
	Proposed Built Up Area (Sq.mt.)	Proposed FAR Area (Sq.mt.)	Total Proposed Built Up Area (Sq.mt.)	Total FAR Area (Sq.mt.)
Ground Floor	111.24	111.24	111.24	111.24
First Floor	111.24	111.24	111.24	111.24
Terrace Floor	0.00	0.00	0.00	0.00
Total :	222.48	222.48	222.48	222.48

FAR & Tenement Details (Table 4c-1)

Building	No. of Same Bldg	Total Built Up Area (Sq.mt.)	Proposed FAR Area (Sq.mt.)	Total FAR Area (Sq.mt.)	Total Consumed Additional FAR Area (Sq.mt.)	Tnmt (No.)
A (RESIDENTIAL)	1	222.48	222.48	222.48	222.48	01
Grand Total :	1	222.48	222.48	222.48	222.48	01

LTP NAME AND SIGNATURE	STRUCTURAL ENG'S NAME AND SIGNATURE	BUILDER NAME AND SIGNATURE	DIGITAL SIGNATURE
Umeh Prasad MNNP/ENG/0002/2024			

Proposal Basic Information

Proposal File No.	MNNP/PI/02011/W08/2024
Owner Name	KANTI PANDEY
Khata No	163
Plot No	250,251
Village Name	Baralota
Use	Residential
SubUse	Bungalow/ Dwelling / Non Apartment

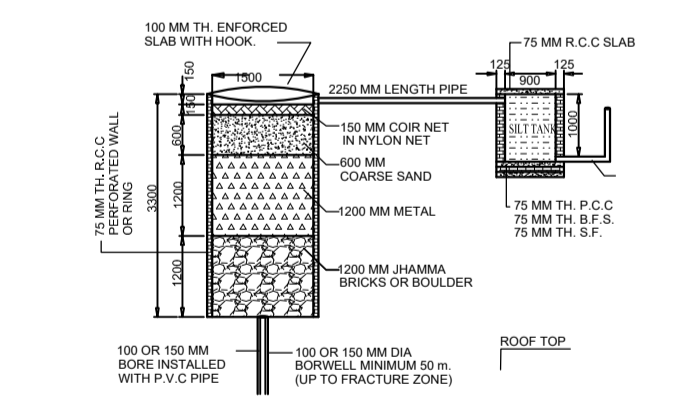
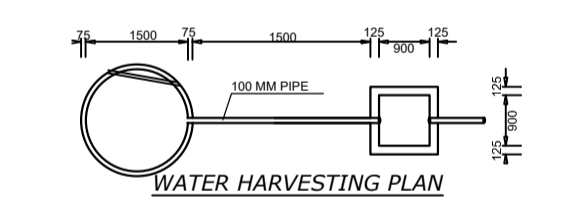
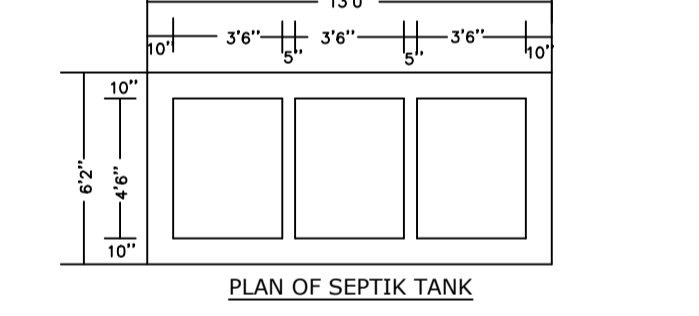
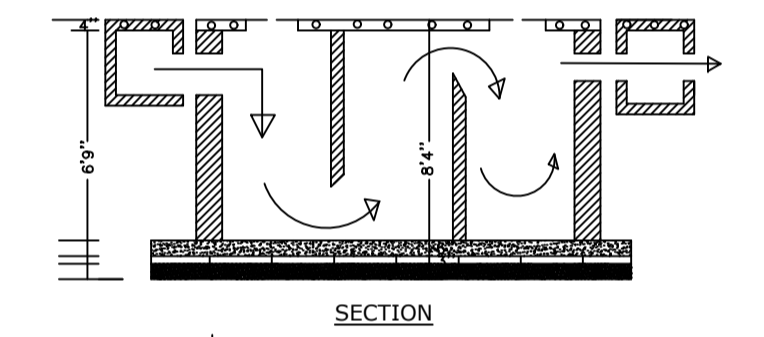
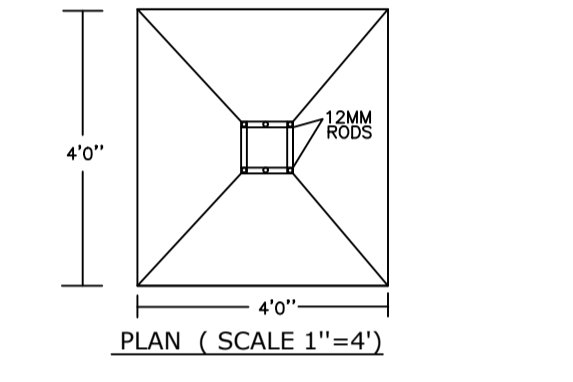
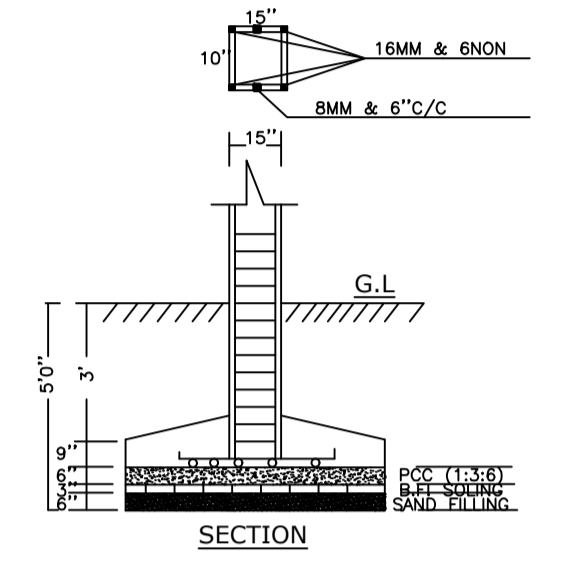
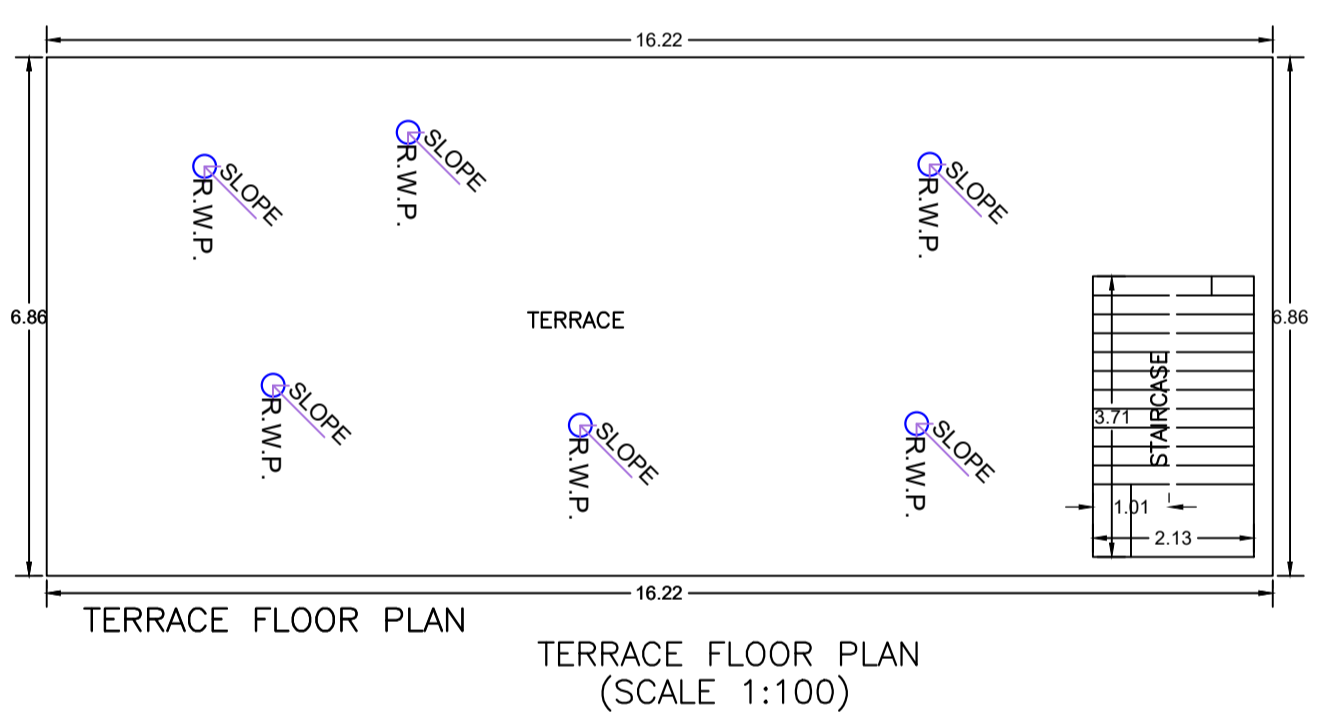
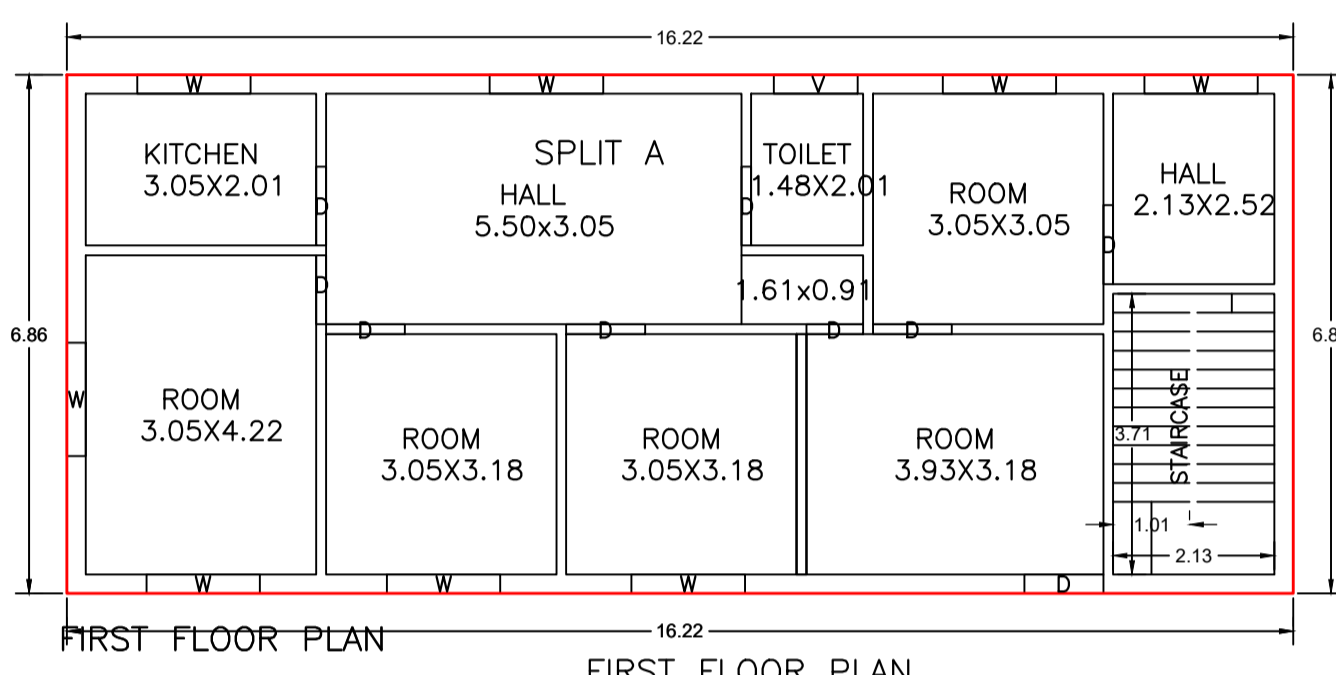
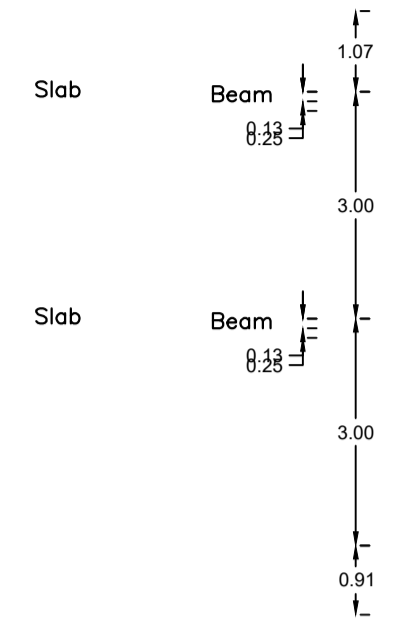
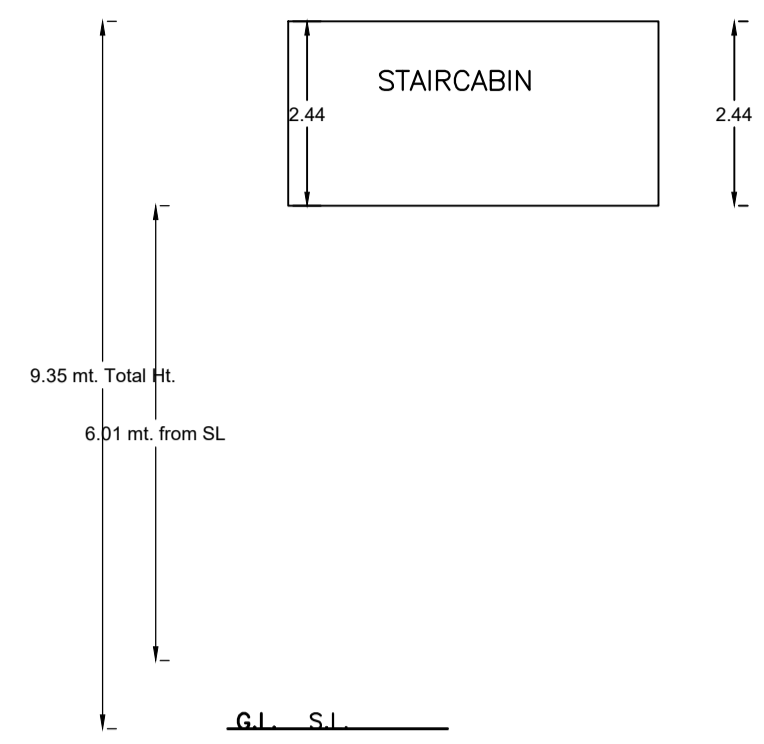
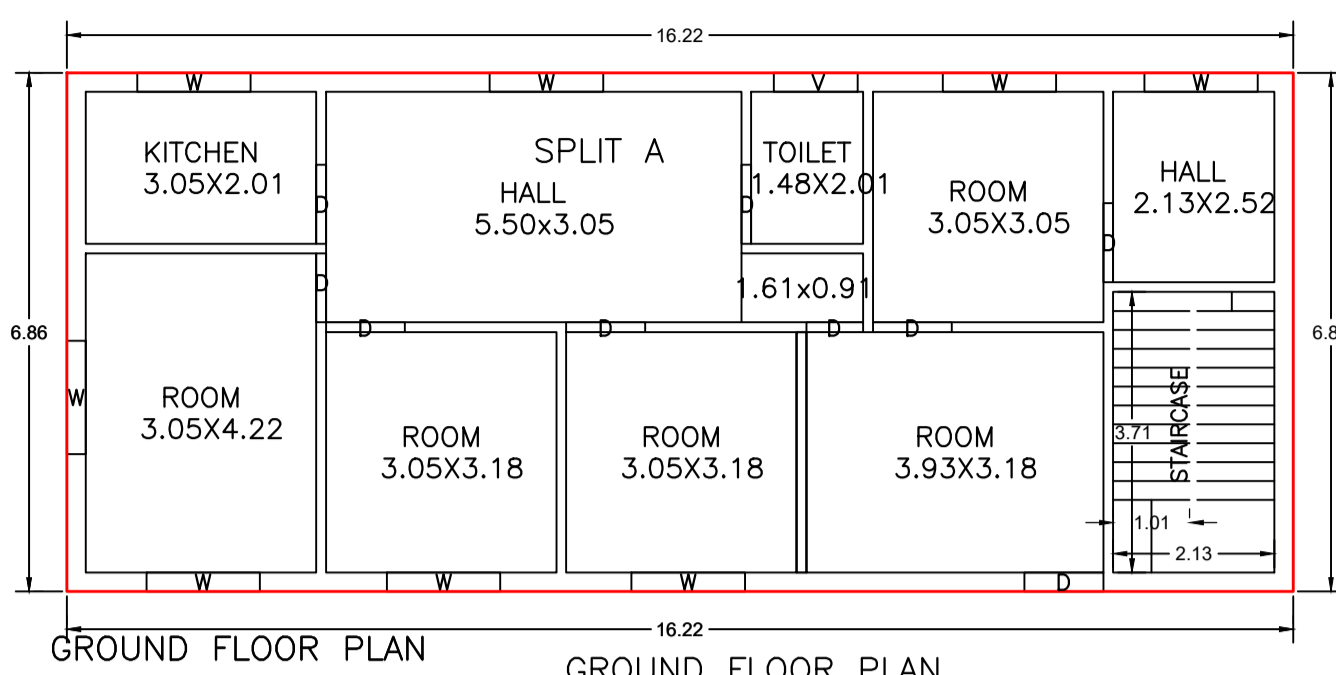

Building :A (RESIDENTIAL)

Floor Name	Total Built Up Area (Sq.mt.)	Proposed FAR Area (Sq.mt.) Resi.	Total FAR Area (Sq.mt.)	Total Consumed Additional FAR Area (Sq.mt.)	Tnmt (No.)
Ground Floor	111.24	111.24	111.24	111.24	01
First Floor	111.24	111.24	111.24	111.24	00
Terrace Floor	0.00	0.00	0.00	0.00	00
Total :	222.48	222.48	222.48	222.48	01
Total Number of Same Buildings :	1				
Total :	222.48	222.48	222.48	222.48	01

SCHEDULE OF DOOR:

BUILDING NAME	NAME	LENGTH	HEIGHT	NOS
A (RESIDENTIAL)	D	0.75	2.10	02
A (RESIDENTIAL)	D	0.91	2.10	02
A (RESIDENTIAL)	D	1.04	2.10	14

SCHEDULE OF WINDOW/VENTILATION:

BUILDING NAME	NAME	LENGTH	HEIGHT	NOS
A (RESIDENTIAL)	V	1.11	1.20	02
A (RESIDENTIAL)	W	1.50	1.20	16

UnitBUA Table for Building :A (RESIDENTIAL)

FLOOR	Name	UnitBUA Type	UnitBUA Area	Carpet Area	No. of Rooms	No. of Tenement
GROUND FLOOR PLAN	SPLIT A	FLAT	203.62	202.80	9	1
FIRST FLOOR PLAN	SPLIT A	FLAT	0.00	0.00	9	0
Total:	-	-	203.62	202.80	18	1

LTP NAME AND SIGNATURE	STRUCTURAL ENG'S NAME AND SIGNATURE	BUILDER NAME AND SIGNATURE	DIGITAL SIGNATURE
Umesh Prasad MNNP/ENG/0002/2024			