

FAR & Tenement Details (Table 4c-1)

Building	No. of Same Bldg	Total Built Up Area (Sq.mt.)	Deductions (Area in Sq.mt.)		Proposed FAR Area (Sq.mt.)		Add Area in FAR (Sq.mt.)	Total FAR Area (Sq.mt.)	Total Consumed Additional FAR Area (Sq.mt.)	Trmt (No.)
			Lift	Parking	Resi.	Commercial				
A (BUILDING)	1	196.04	7.36	49.13	102.97	25.66	7.24	139.55	139.55	02
Grand Total	1	196.04	7.36	49.13	102.97	25.66	7.24	139.55	139.55	02

Proposal Basic Information

Proposal File No.	MNNP/BP/0210/W04/2024
Owner Name	MOHAMMAD SAIFULLAH MD SANALLAH
Khata No	0
Plot No	467
Village Name	Hamidganj
Use	Commercial
SubUse	Commercial Bldg

Building USE/SUBUSE Details

Building Name	Building Use	Building SubUse	Building Structure	Floor Name	Floor Use	Floor SubUse	FAR Name	FAR Use	FAR SubUse
A (BUILDING)	Commercial	Commercial Bldg	Non-Highrise	GROUND FLOOR PLAN	Commercial	Commercial Bldg	-	-	-
				FIRST FLOOR PLAN	Residential	Residential Bldg/Apartment	Residential FAR	Residential	Residential Bldg/Apartment
				SECOND FLOOR PLAN	Residential	Residential Bldg/Apartment	Commercial FAR	Commercial	Shop
				TERRACE FLOOR PLAN	Commercial	Commercial Bldg	-	-	-

AREA STATEMENT	VERSION NO. : 1.0.71
MEDINAGAR MUNICIPAL CORPORATION	VERSION DATE: 16/10/2020
PROJECT DETAIL:	
Region : JHARKHAND URBAN LOCAL BODIES	Plot Use: Commercial
District: PALAMU	Plot SubUse: Commercial Bldg
Authority: MEDINAGAR MUNICIPAL CORPORATION	PlotNearby/ReligiousStructure: NA
Inward No: MNNP/BP/0210/W04/2024	Plot/SubPlot No: 467
Application Type: General Proposal	North: -
Project Type: Building Permission	South: -
Nature of Development: New	East: -
Location of Development Area: New Area	West: -
AREA DETAILS:	
AREA OF PLOT (Minimum)	(A) 120.87 SQ.MT.
NET AREA OF PLOT(Gross Plot Area - Deduction from Gross Plot area)	(A-Deductions) 120.87
Deduction for Balance Plot Area(from Gross Plot Area)	
Common Plot	18.08
Total	18.08
BALANCE AREA OF PLOT(Net Plot Area - Recreational/Amenity space)	(A-Deductions) 102.78
PLOT AREA FOR COVERAGE(Net Plot Area)	(A-Deductions) 120.87
Plot Area for FAR (Net Plot Area + RoadWidening Area)	(A-Deductions) 120.87
COVERAGE CHECK	
Permissible Coverage area (50.00 %)	60.43
Proposed Coverage Area (49.69 %)	60.06
Total Prop. Coverage Area (49.69 %)	60.06
Balance coverage area (0.31 %)	0.37
FAR CHECK	
Perm. FAR Area (2.500)	302.15
Total Perm. FAR area	302.15
Residential FAR	102.97
Commercial FAR	25.66
Proposed FAR Area	139.55
Total Proposed FAR Area	139.55
Consumed FAR (Factor)	1.15
Balance FAR Area	162.60
BUILT UP AREA CHECK	
Total Proposed BuiltUp Area	196.04
ARCHITECT (Regd)	MD ZAQUEALLAH
ENGINEER (Regd)	
SUPERVISOR (Regd)	
OWNER (Regd)	MOHAMMAD SAIFULLAH MD SANALLAH
DEVELOPMENT AUTHORITY	
	LOCAL BODY

Required Parking(Table 7a)

Building Name	Type	SubUse	Area (Sq.mt.)	Units		Car		Visitors Car		TwoWheeler			
				Reqd.	Prop.	Reqd./Unit	Reqd.	Prop.	Reqd./Unit	Reqd.	Prop.	Reqd./Unit	Reqd.
A (BUILDING)	Residential	Residential Bldg/Apartment	> 0	1	1.00	1	1	-	-	-	-	-	
			> 0	1	1.00	-	-	-	-	1	1	-	-
	Commercial	Shop	> 0	50	25.66	1	1	-	-	-	-	-	
			> 0	50	25.66	-	-	-	-	1	2	-	-
Total :			-	-	-	2	4	-	1	1	-	3	8

Parking Check (Table 7b)

Vehicle Type	Reqd.		Prop.	
	No.	Area	No.	Area
Car	-	-	1	12.50
Four Slack Car	-	-	3	37.50
Total Car	2	25.00	4	50.00
Visitor's Car Parking	-	-	1	12.50
Total Visitor Parking	1	12.50	1	12.50
TwoWheeler	-	-	8	16.00
Total TwoWheeler	3	6.00	8	16.00
Other Parking	-	-	-	8.13
Total		43.50		102.63

COLOR INDEX	
PLOT BOUNDARY	Black
ABUTTING ROAD	Green
PROPOSED CONSTRUCTION	Red
COMMON PLOT	Yellow
ROAD WIDENING AREA	Orange
EXISTING (To be retained)	Blue
EXISTING (To be demolished)	Light Blue

Buildingwise Floor FAR Details

Floor Name	Building Name		Total	
	Proposed Built Up Area (Sq.mt.)	Proposed FAR Area (Sq.mt.)	Total Proposed Built Up Area (Sq.mt.)	Total FAR Area (Sq.mt.)
Ground Floor	60.06	10.93	60.06	10.93
First Floor	67.99	64.31	67.99	64.31
Second Floor	67.99	64.31	67.99	64.31
Terrace Floor	0.00	0.00	0.00	0.00
Total :	196.04	139.55	196.04	139.55

LTP NAME AND SIGNATURE	STRUCTURAL ENG'S NAME AND SIGNATURE	BUILDER NAME AND SIGNATURE	DIGITAL SIGNATURE
MD ZAQUEALLAH MNNP/ENG/002/2021			

Proposal Basic Information	
Proposal File No.	MNNP/BI/0210/W04/2024
Owner Name	MOHAMMAD SAIFULLAH MD SANALLAH
Khata No	0
Plot No	467
Village Name	Hamidganj
Use	Commercial
SubUse	Commercial Bldg

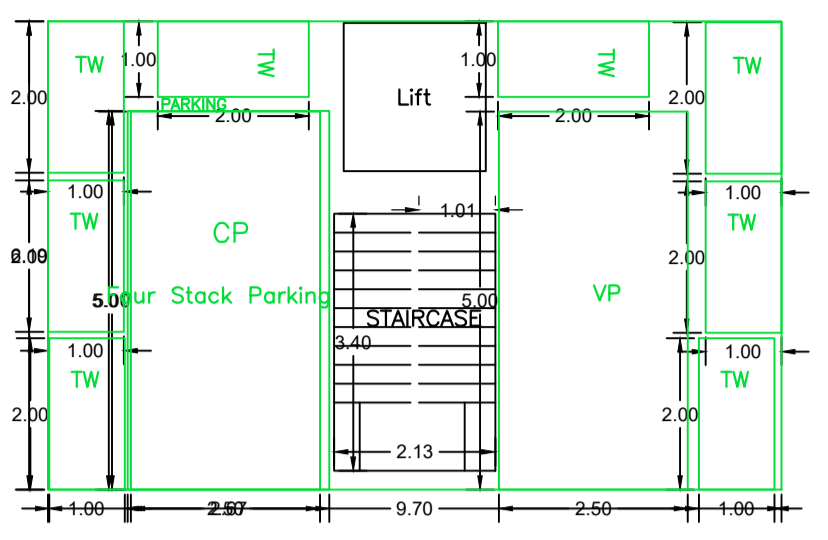

GROUND FLOOR PLAN (SCALE 1:100)

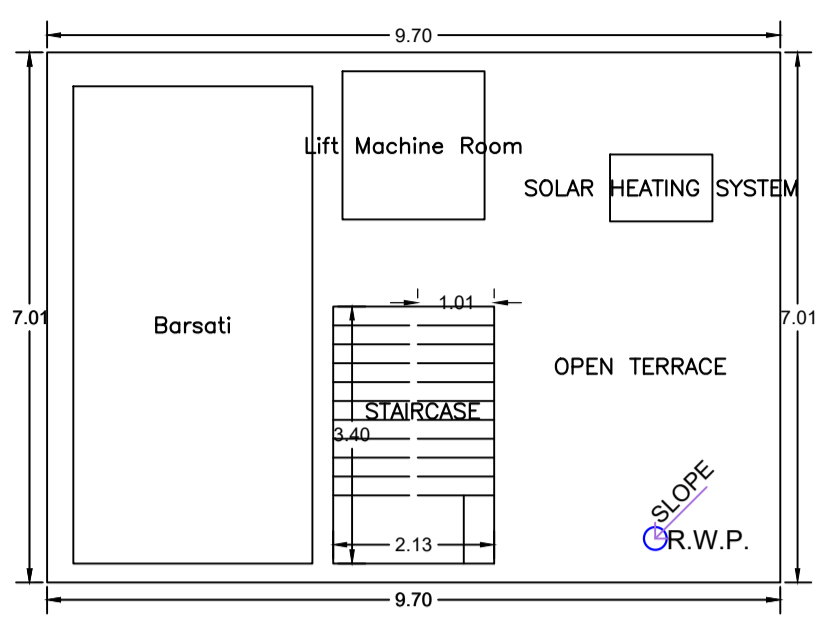

TERRACE FLOOR PLAN (SCALE 1:100)

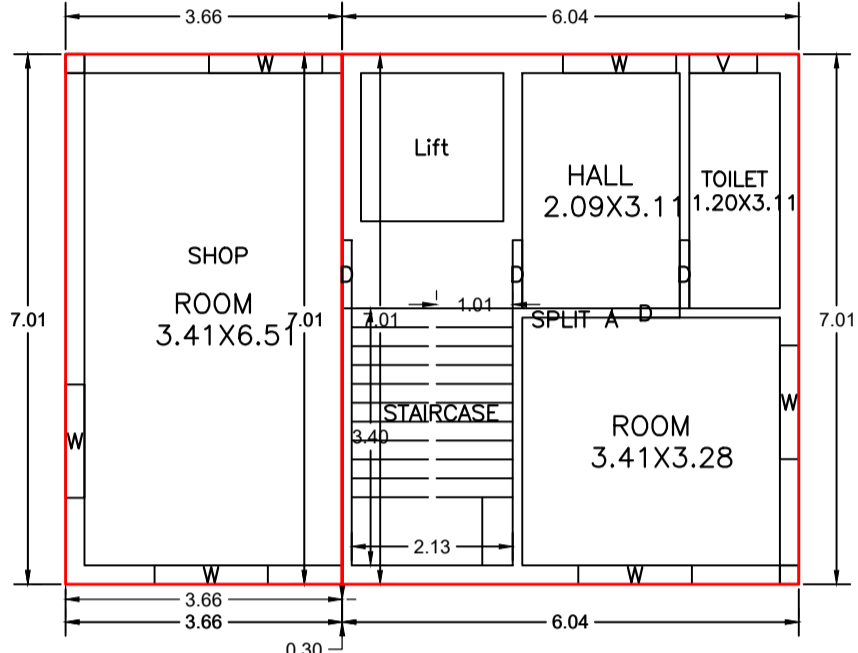

FIRST FLOOR PLAN (Proposed) (SCALE 1:100)

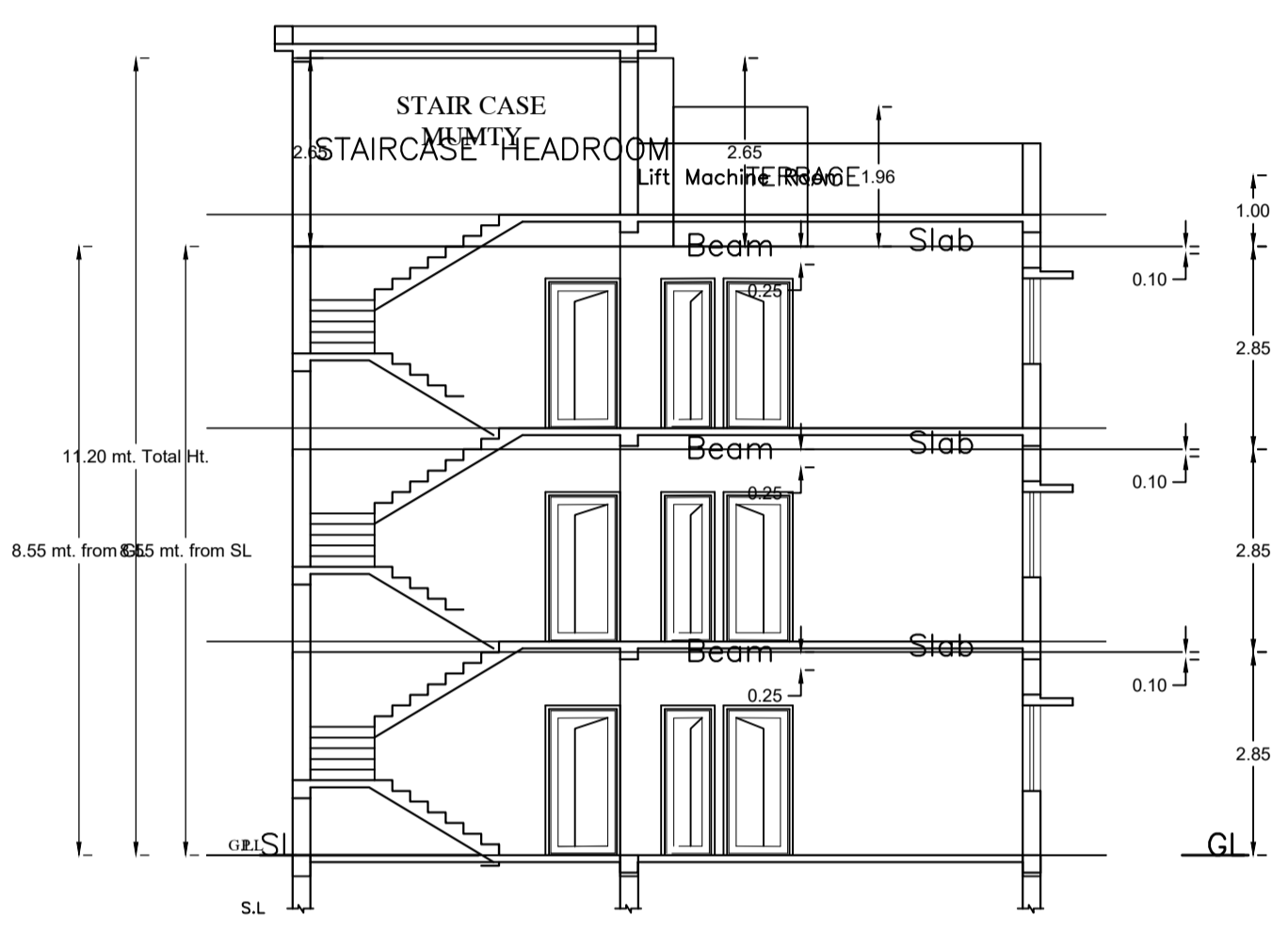

SECTION X-X (SCALE 1:100)

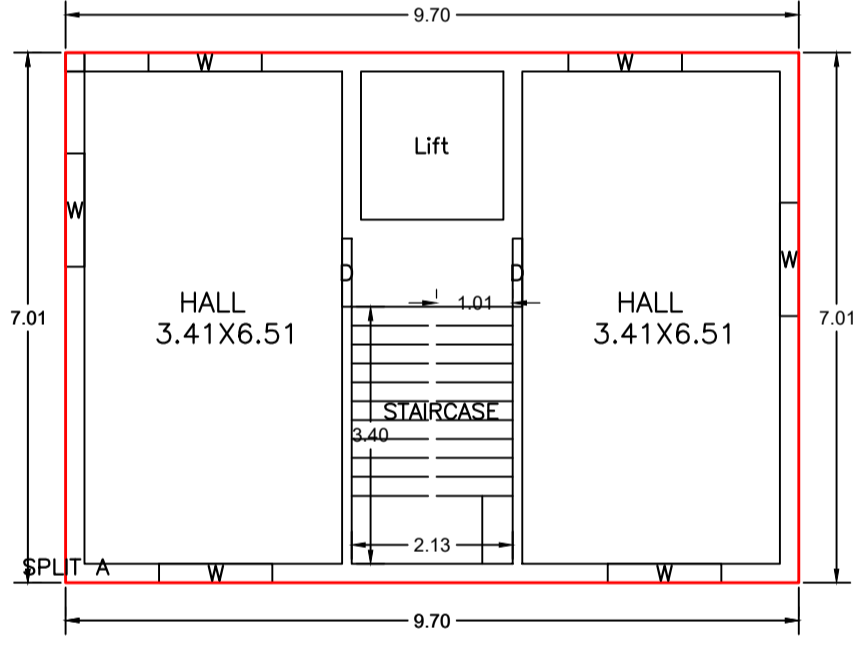

SECOND FLOOR PLAN (Proposed) (SCALE 1:100)



RIGHT SIDE ELEVATION (SCALE 1:100)

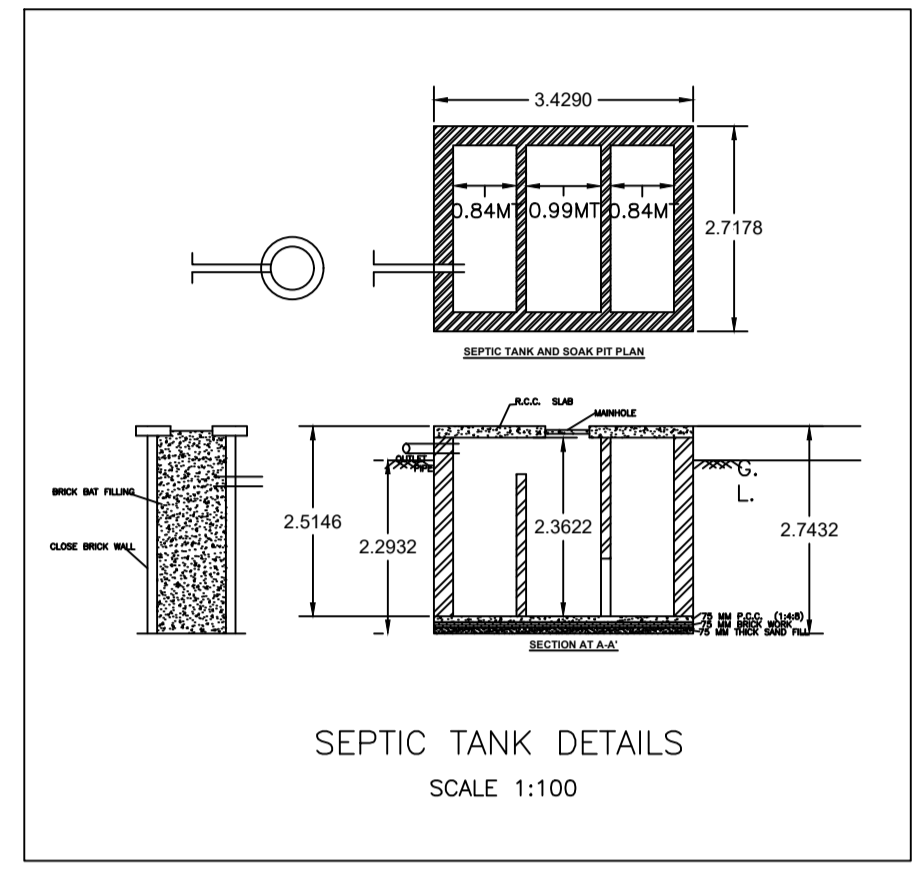

SEPTIC TANK DETAILS (SCALE 1:100)



FRONT ELEVATION (SCALE 1:100)

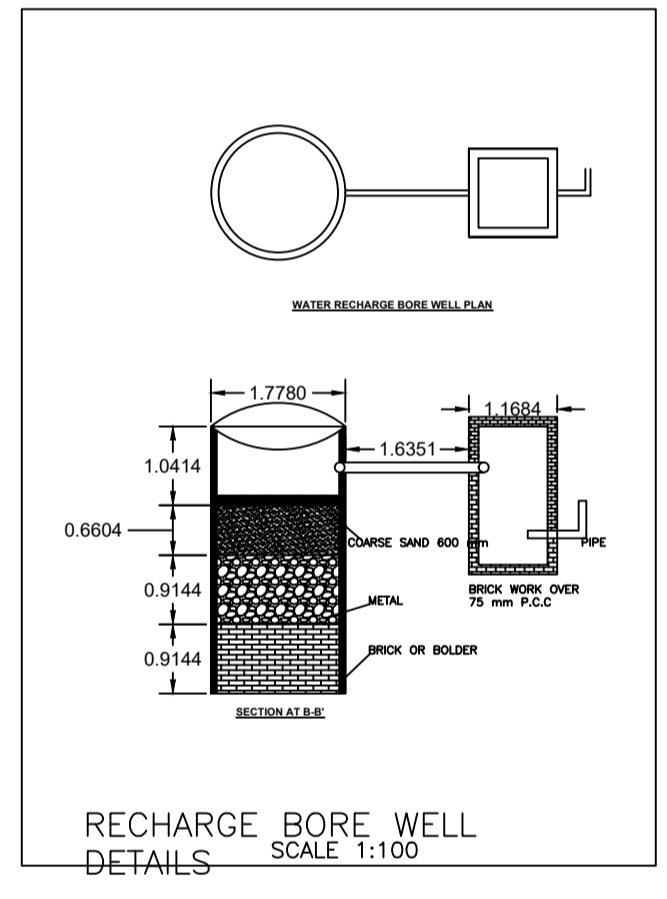

RECHARGE BORE WELL DETAILS (SCALE 1:100)

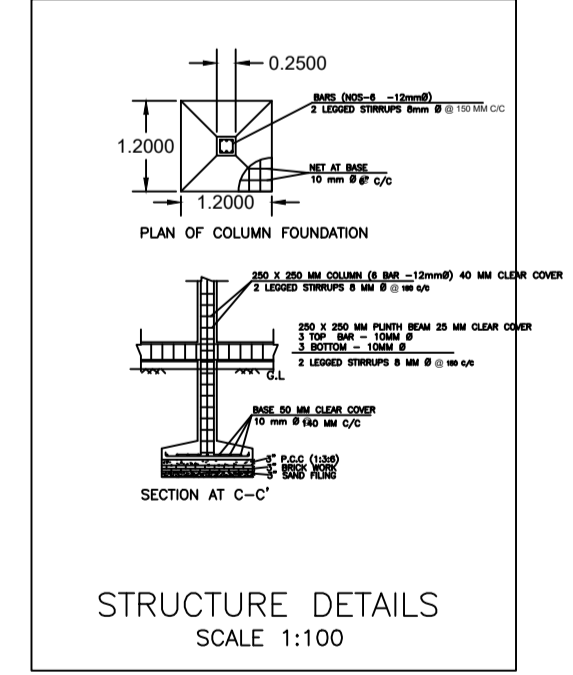

STRUCTURE DETAILS (SCALE 1:100)

Floor Name	Total Built Up Area (Sq.mt.)	Deductions (Area in Sq.mt.)		Proposed FAR Area (Sq.mt.)		Add Area In FAR (Sq.mt.)	Total FAR Area (Sq.mt.)	Total Consumed Additional FAR Area (Sq.mt.)	Trmt (No.)
		Lift	Parking	Resi.	Commercial				
Ground Floor	60.06	0.00	49.13	0.00	0.00	7.24	10.93	10.93	00
First Floor	67.99	3.68	0.00	38.66	25.66	0.00	64.31	64.31	02
Second Floor	67.99	3.68	0.00	64.31	0.00	0.00	64.31	64.31	00
Terrace Floor	0.00	0.00	0.00	0.00	0.00	0.00	0.00	0.00	00
Total :	196.04	7.36	49.13	102.97	25.66	7.24	139.55	139.55	02
Total Number of Same Buildings :	1								
Total :	196.04	7.36	49.13	102.97	25.66	7.24	139.55	139.55	02

SCHEDULE OF DOOR:

BUILDING NAME	NAME	LENGTH	HEIGHT	NOS
A (BUILDING)	D	0.90	2.10	06

SCHEDULE OF WINDOW/VENTILATION:

BUILDING NAME	NAME	LENGTH	HEIGHT	NOS
A (BUILDING)	V	0.90	0.60	01
A (BUILDING)	W	1.50	1.20	12

UnitBUA Table for Building :A (BUILDING)

FLOOR	Name	UnitBUA Type	UnitBUA Area	Carpet Area	No. of Rooms	No. of Tenement
FIRST FLOOR	SHOP	SHOP	25.66	25.59	1	2
PLAN	SPLIT A	FLAT	85.33	85.20	3	0
SECOND FLOOR PLAN	SPLIT A	FLAT	0.00	0.00	2	0
Total:	-	-	110.98	110.80	6	2

LTP NAME AND SIGNATURE	STRUCTURAL ENG'S NAME AND SIGNATURE	BUILDER NAME AND SIGNATURE	DIGITAL SIGNATURE
MD ZAQUEALLAH MNNP/ENG/0002/2021			