

Proposal Basic Information

Proposal File No.	MNNP/BP/0023/W08/2024
Owner Name	Puja Devi
Khata No	301
Plot No	292
Village Name	Baralota
Use	Residential
SubUse	Bungalow Dwelling / Non Apartment

FAR & Tenement Details (Table 4c-1)

Building	No. of Same Bldg	Total Built Up Area (Sq.mt.)	Proposed FAR Area (Sq.mt.) Resi.	Total FAR Area (Sq.mt.)	Total Consumed Additional FAR Area (Sq.mt.)	Tnmt (No.)
A (RESIDENTIAL)	1	71.29	71.29	71.29	71.29	01
Grand Total :		71.29	71.29	71.29	71.29	01

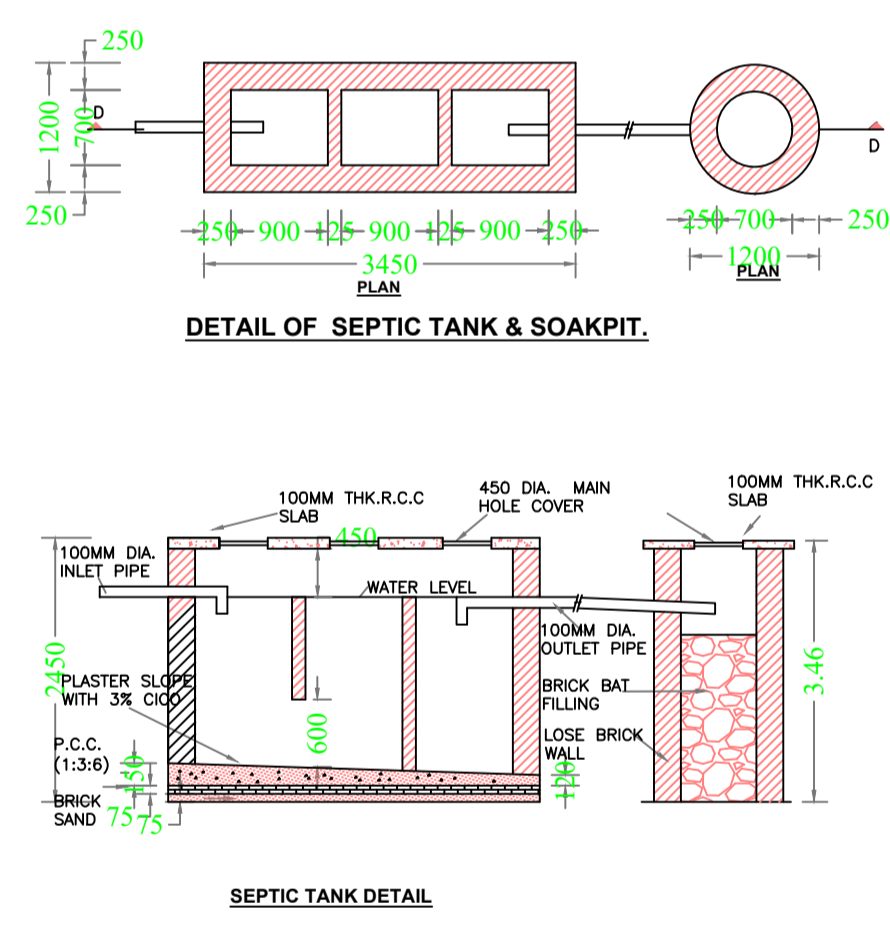
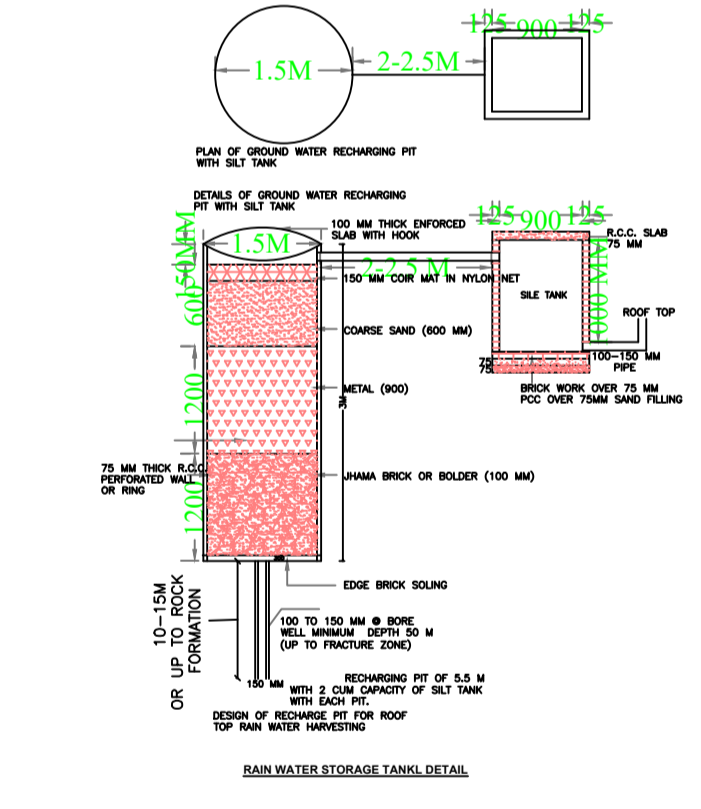
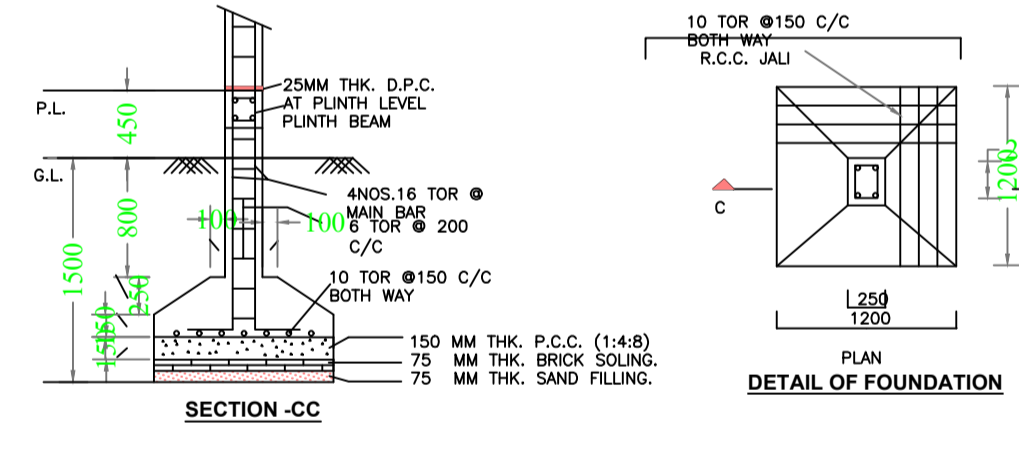
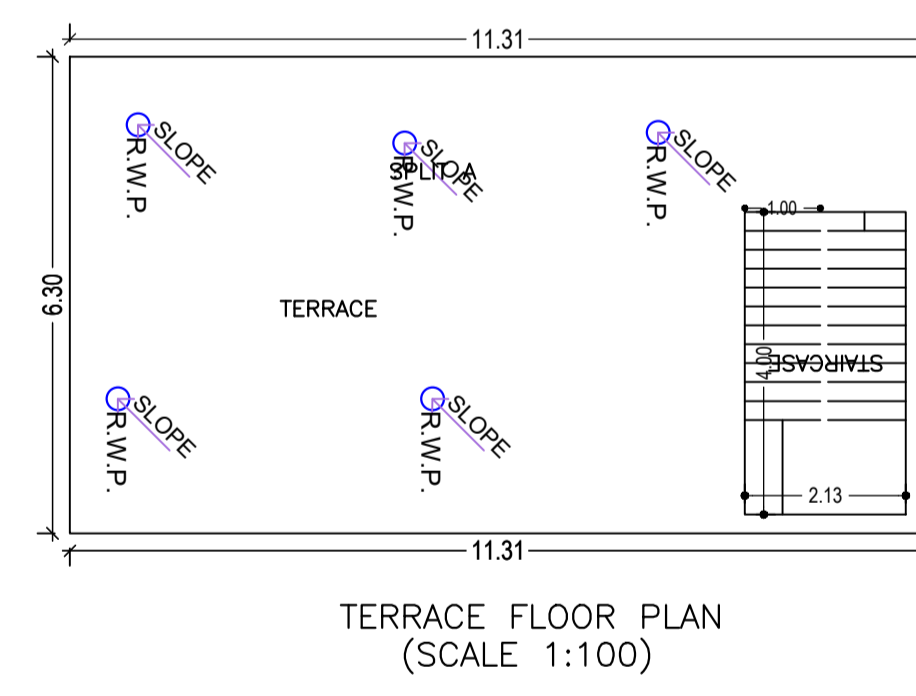
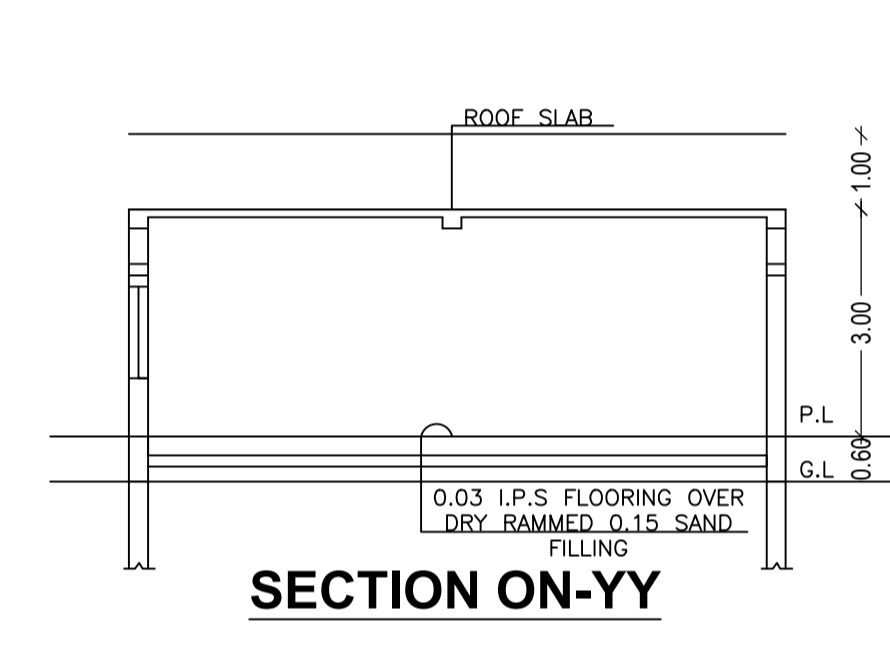
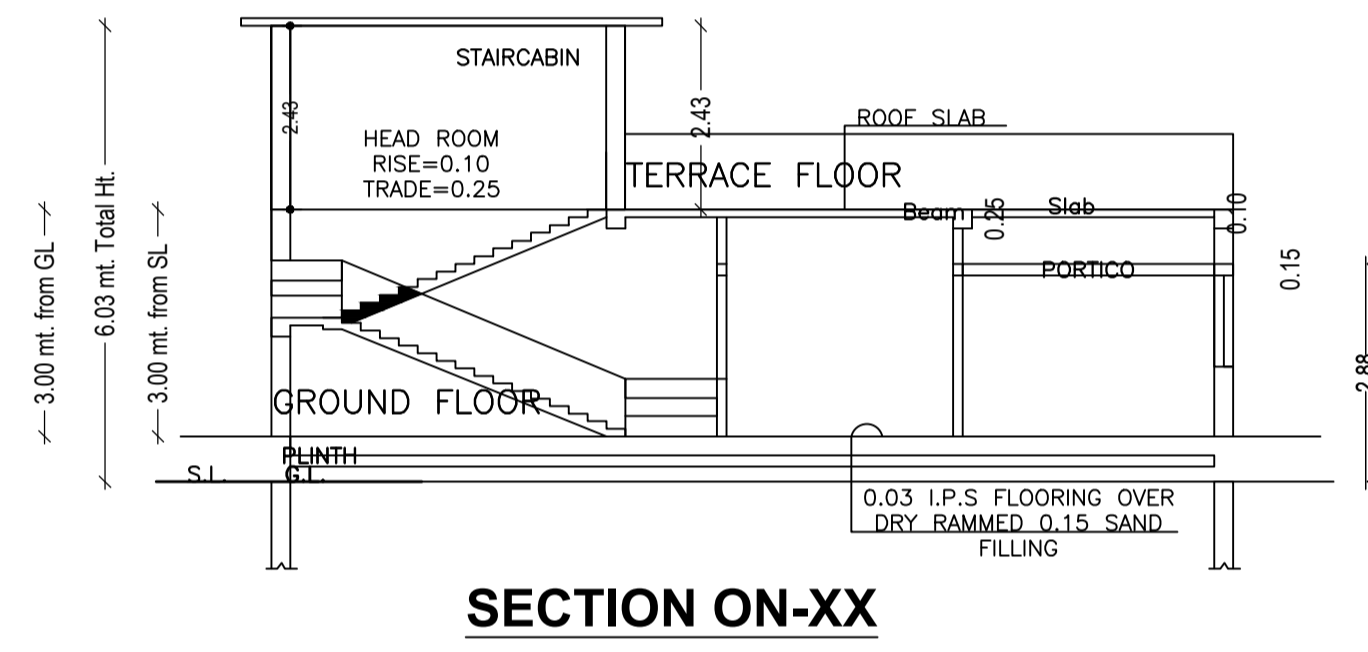
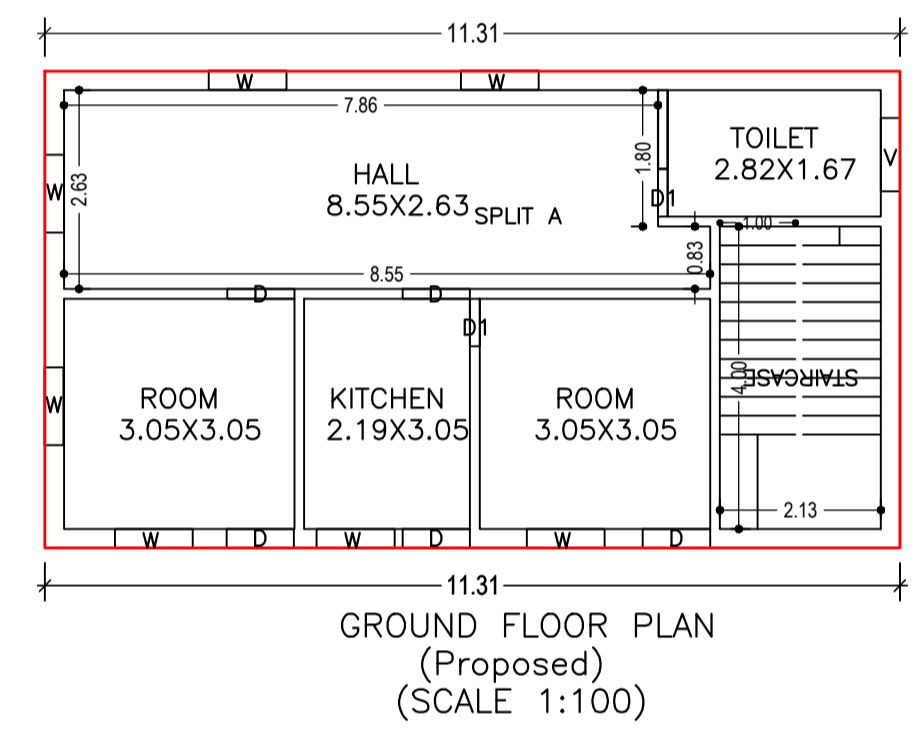
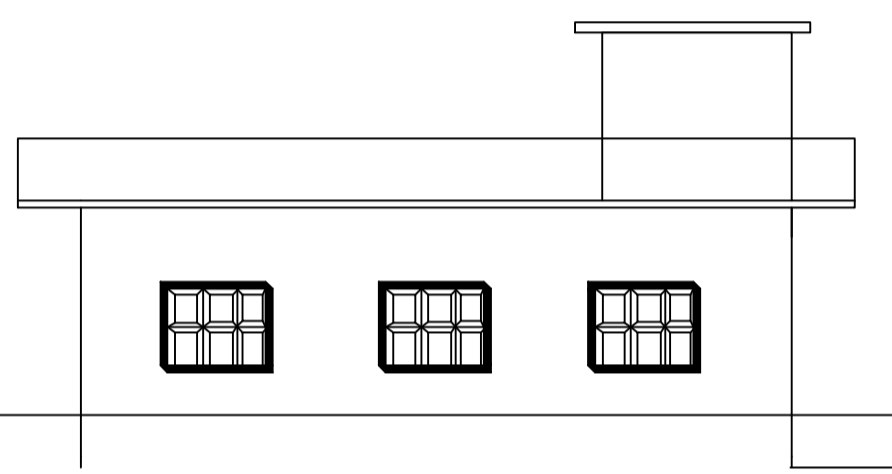
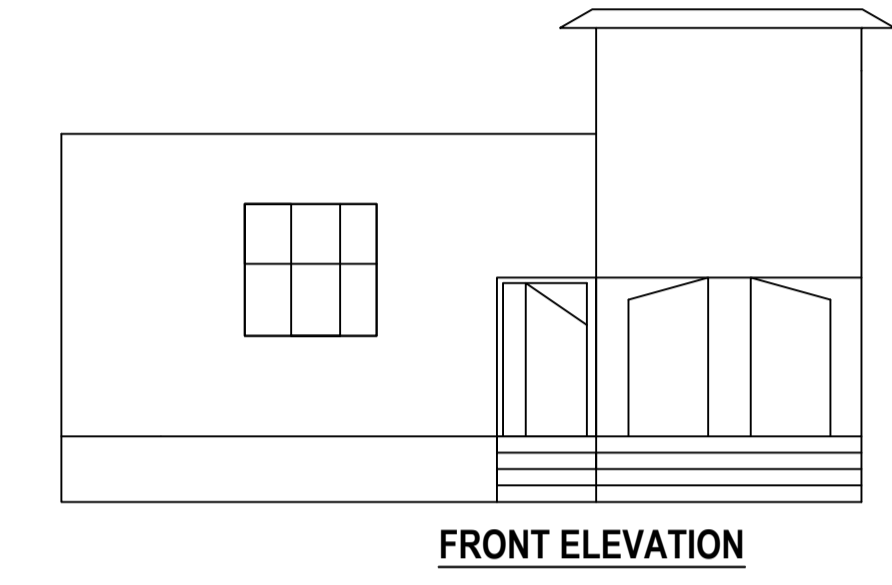
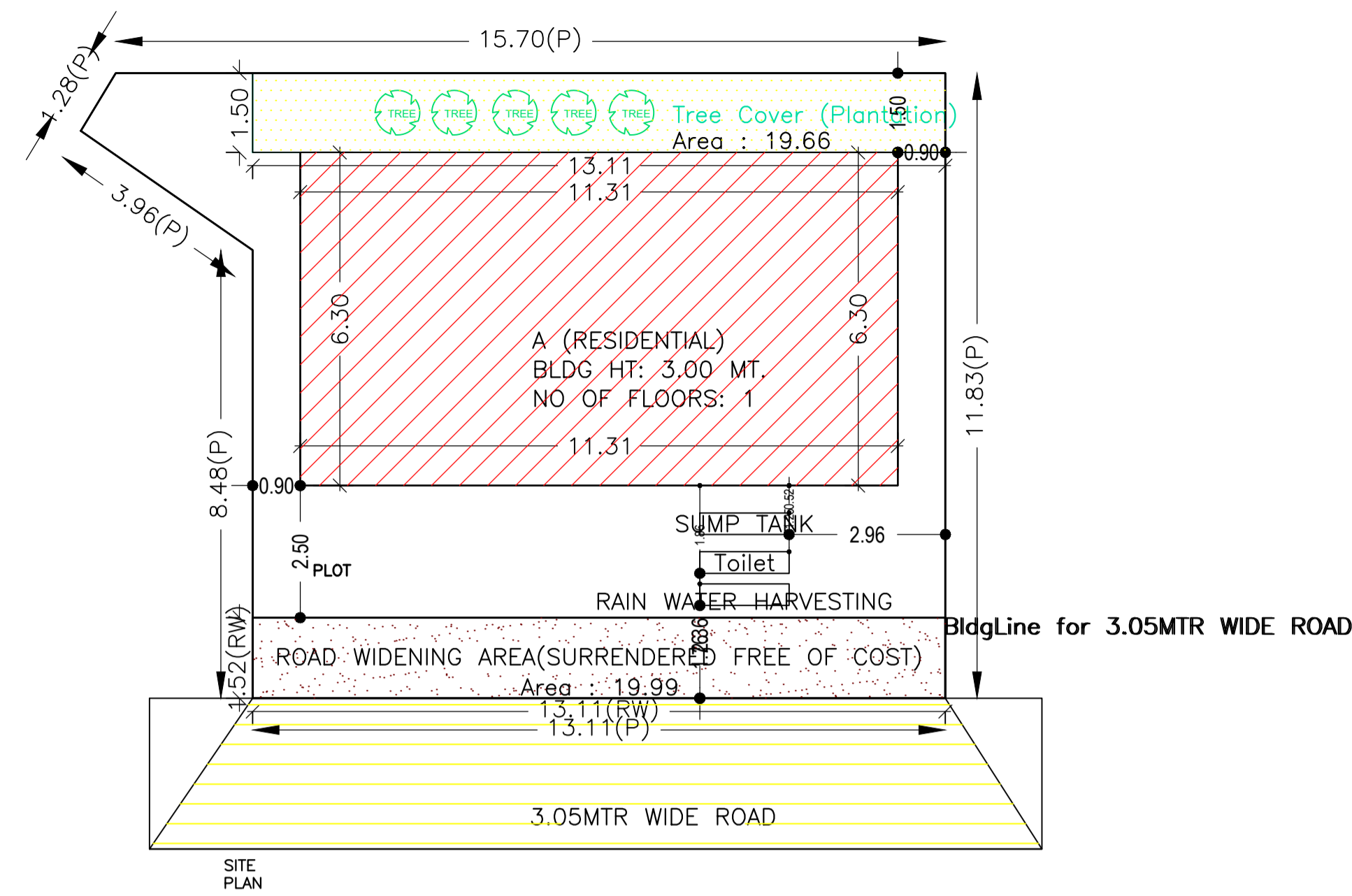

AREA STATEMENT	VERSION NO. : 1.0.68
MEDINAGAR MUNICIPAL CORPORATION	VERSION DATE: 16/10/2020
PROJECT DETAIL:	
Region : JHARKHAND URBAN LOCAL BODIES	Plot Use: Residential
District: PALANJU	Plot SubUse: Bungalow/ Dwelling / Non Apartment
Authority: MEDINAGAR MUNICIPAL CORPORATION	Plot/Nearby/Religious/Structure: NA
Inward No: MNNP/BP/0023/W08/2024	Plot/SubPlot No: 292
Application Type: General Proposal	North: -
Project Type: Building Permission	South: -
Nature of Development: New	East: -
Location of Development Area: New	West: -
AREA DETAILS:	SQ.MT.
AREA OF PLOT (Minimum)	(A) 161.93
Deduction for NetPlot Area	
Surrender Free of Cost	19.99
Total	19.99
NET AREA OF PLOT(Gross Plot Area - Deduction from Gross Plot area)	(A-Deductions) 141.94
Deduction for Balance Plot Area(from Gross Plot Area)	
Surrender Free of Cost	19.99
Common Plot	19.66
Total	39.65
BALANCE AREA OF PLOT(Net Plot Area - Recreational/Amenity space)	(A-Deductions) 122.28
PLOT AREA FOR COVERAGE(Net Plot Area)	(A-Deductions) 141.94
Plot Area for FAR (Net Plot Area + Road/Widening Area)	(A-Deductions) 161.93
COVERAGE CHECK	
Permissible Coverage area (70.00 %)	99.36
Proposed Coverage Area (50.23 %)	71.29
Total Prop. Coverage Area (50.23 %)	71.29
Balance coverage area (19.78 %)	28.07
FAR CHECK	
Perm. FAR Area (1.200)	194.32
Total Perm. FAR area	194.32
Residential FAR	71.29
Proposed FAR Area	71.29
Total Proposed FAR Area	71.29
Consumed FAR (Factor)	0.44
Balance FAR Area	123.03
BUILT UP AREA CHECK	
Total Proposed BuiltUp Area	71.29
ARCHITECT (Regd)	RANJIT KUMAR
ENGINEER (Regd)	
SUPERVISOR (Regd)	
OWNER (Regd)	Puja Devi
DEVELOPMENT AUTHORITY	LOCAL BODY

COLOR INDEX	
PLOT BOUNDARY	Black
ABUTTING ROAD	Red
PROPOSED CONSTRUCTION	Green
COMMON PLOT	Blue
ROAD WIDENING AREA	Yellow
EXISTING (To be retained)	Light Blue
EXISTING (To be demolished)	Light Yellow

Building :A (RESIDENTIAL)

Floor Name	Total Built Up Area (Sq.mt.)	Proposed FAR Area (Sq.mt.) Resi.	Total FAR Area (Sq.mt.)	Total Consumed Additional FAR Area (Sq.mt.)	Tnmt (No.)
Ground Floor	71.29	71.29	71.29	71.29	01
Terrace Floor	0.00	0.00	0.00	0.00	00
Total :	71.29	71.29	71.29	71.29	01
Total Number of Same Buildings :	1				
Total :	71.29	71.29	71.29	71.29	01

SCHEDULE OF DOOR:

BUILDING NAME	NAME	LENGTH	HEIGHT	NOS
A (RESIDENTIAL)	D1	0.63	2.10	02
A (RESIDENTIAL)	D	0.89	2.10	05

SCHEDULE OF WINDOW/VENTILATION:

BUILDING NAME	NAME	LENGTH	HEIGHT	NOS
A (RESIDENTIAL)	V	0.97	0.60	01
A (RESIDENTIAL)	W	1.03	1.20	07

UnitBUA Table for Building :A (RESIDENTIAL)

FLOOR	Name	UnitBUA Type	UnitBUA Area	Carpet Area	No. of Rooms	No. of Tenement
GROUND FLOOR PLAN	SPLIT A	FLAT	61.18	61.04	5	1
Total:	-	-	61.18	61.04	5	1

LTP NAME AND SIGNATURE	STRUCTURAL ENG'S NAME AND SIGNATURE	BUILDER NAME AND SIGNATURE	DIGITAL SIGNATURE
RANJIT KUMAR MNNP/ENG/0001/2016			